

Android Debugging and Performance Analysis



CC-BY-SA 3.0 - Attribution requirements and misc., **PLEASE READ:**



- This slide must remain as-is in this specific location (slide #1), everything else you are free to change; including the logo :-)
- Use of figures in other documents must feature the below "Originals at" URL immediately under that figure and the below copyright notice where appropriate.
- You are FORBIDDEN from using the default "About" slide as-is or any of its contents.

Copyright (C) 2013-2014, Opersys inc.

These slides created by: Karim Yaghmour

Originals at: <http://www.opersys.com/training/>

About

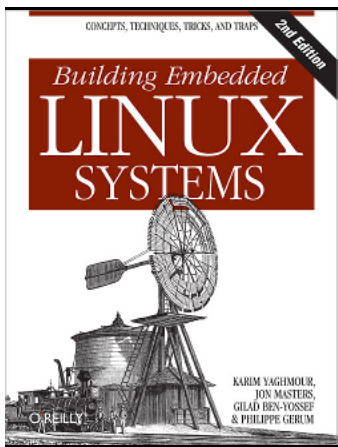
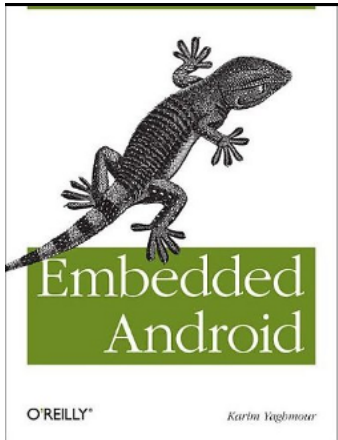

- Introduced Linux Trace Toolkit in 1999
- Originated Adeos and relayfs (kernel/relay.c)
- Training, Custom Dev, Consulting, ...

About this specific class

Android debugging is dirty business

AOSP version used by BSP has issues

... ergo ...

Runtime adjustments will be made

Goals - High Level

- Understand the set of debugging and performance monitoring tools and capabilities available in Android
- Understand the internals and limitations of each
- Get hands-on experience with the tools and capabilities
- Determine which ones are most appropriate, useful and/or important for a given task

Goals - Specifics

- Understand the Android stack's debugging mechanisms and their internals
- Debug from the app level all the way down to kernel drivers
- Using Linux debugging tools with Android
- Learning about Android-specific tools
- Monitor performance and latencies
- Quantify and analyze memory usage
- Breakpoint and step through the stack
- Apply commonly-used techniques for framework debugging
- Familiarize with lesser-known tools and capabilities built into Android

HANDS ON

Prerequisites

- C/C++
- Java
- Linux command line
- Android internals
- Linux kernel internals
- Linux device drivers
- ARM architecture

Topics

1. Internals Architecture Quick Recap
2. Working with the AOSP Sources
3. Classifying and Analyzing Tools
4. Kernel Tools and Capabilities
5. Android-Agnostic User-Space Tools
6. Android-Specific User-Space Tools
7. Dalvik Tools
8. System Services Interfacing
9. Other Tools and Techniques
10. glibc User-Space

Courseware

- These slides
- Exercises
- Online documentation

"Use the Source, Luke, use the Source. Be one with the code." -- Linus Torvalds

Hands-On Environment

Host

- Ubuntu-based system
- 50GB / AOSP

Target

- IFC6410
- Qualcomm Snapdragon S4 Pro – APQ8064
- Krait CPU, 4-core, 1.7 GHz, 2MB L2 cache
- 2 GB on-board DDR3 (PCDDR 533MHz)
- 4 GB eMMC
- Separate power/usb
- Requires monitor/keyboard/mouse

Internals Architecture Quick Recap

- Hardware used to run Android
- AOSP
- Binder
- System Services
- HAL
- Call walkthrough
- System startup
- Debug setup
- Network boot
- Symbolic debugging

1. Hardware used to run Android

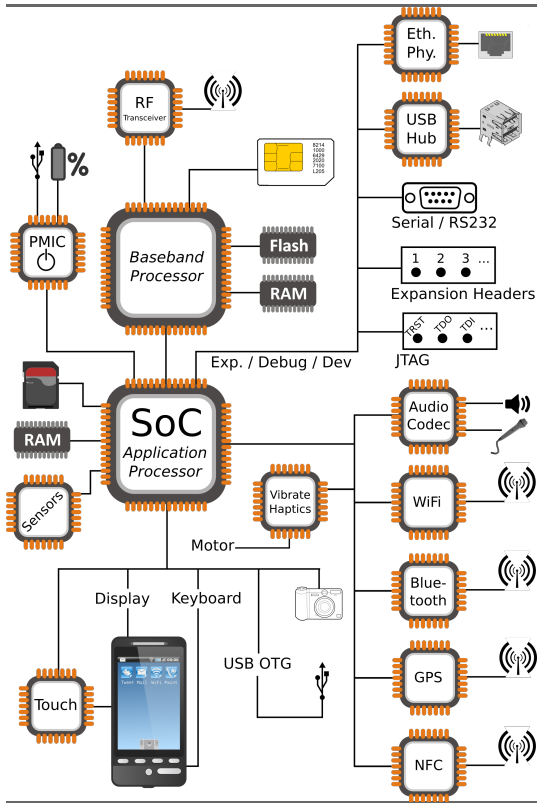

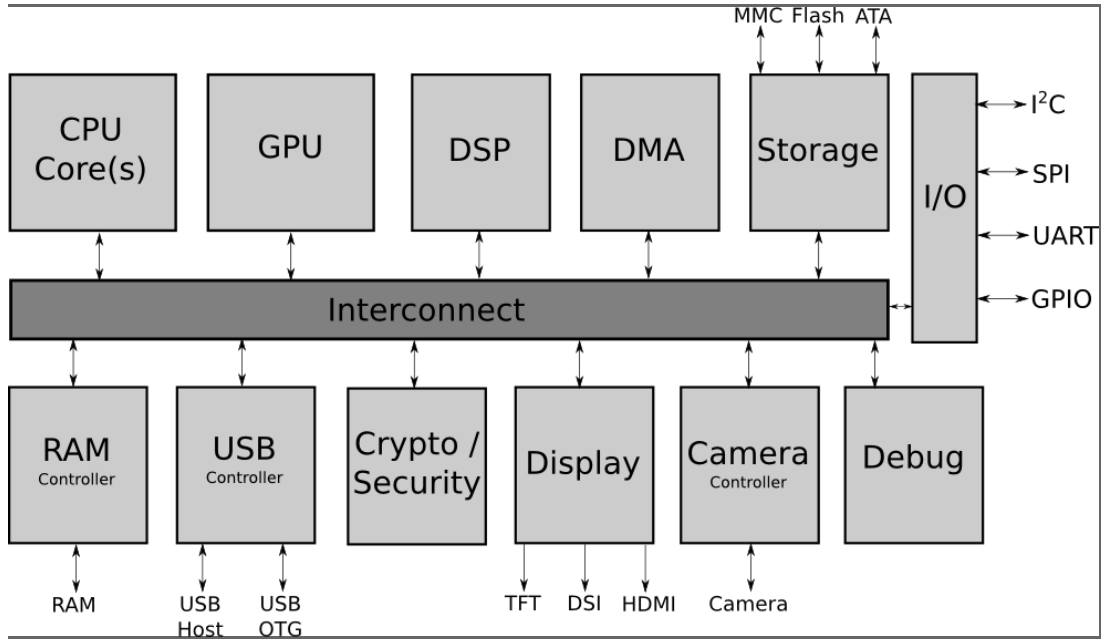

2. AOSP

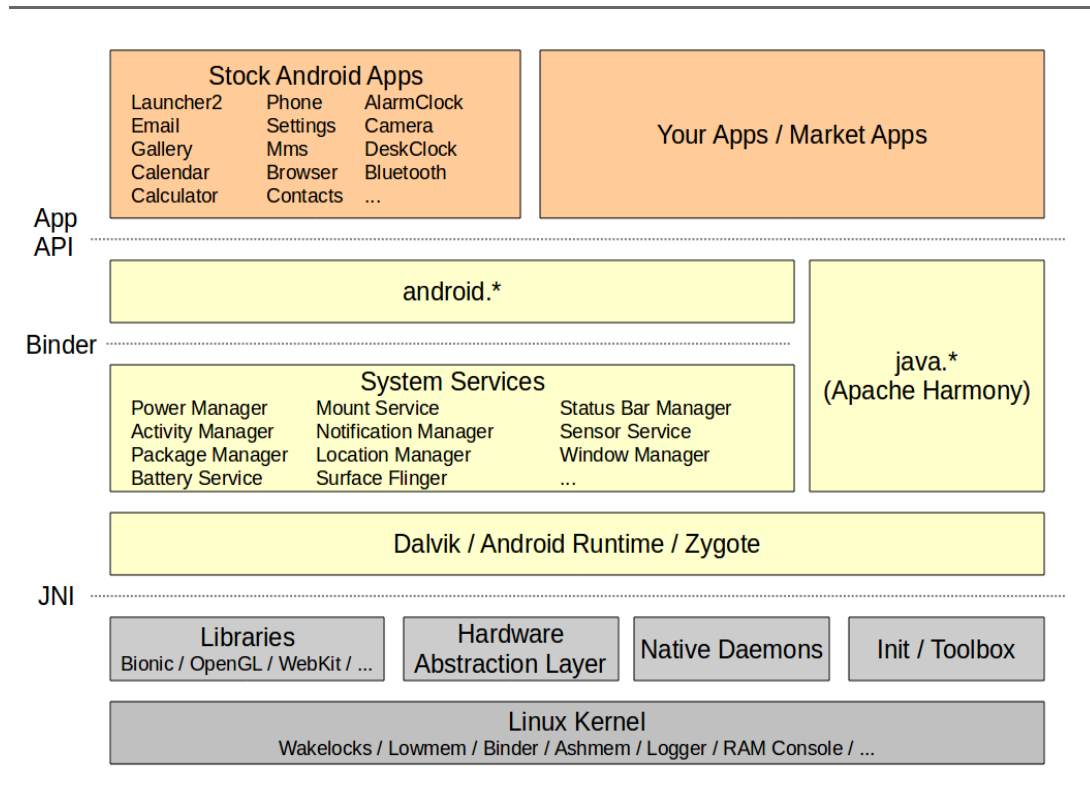

3. Binder

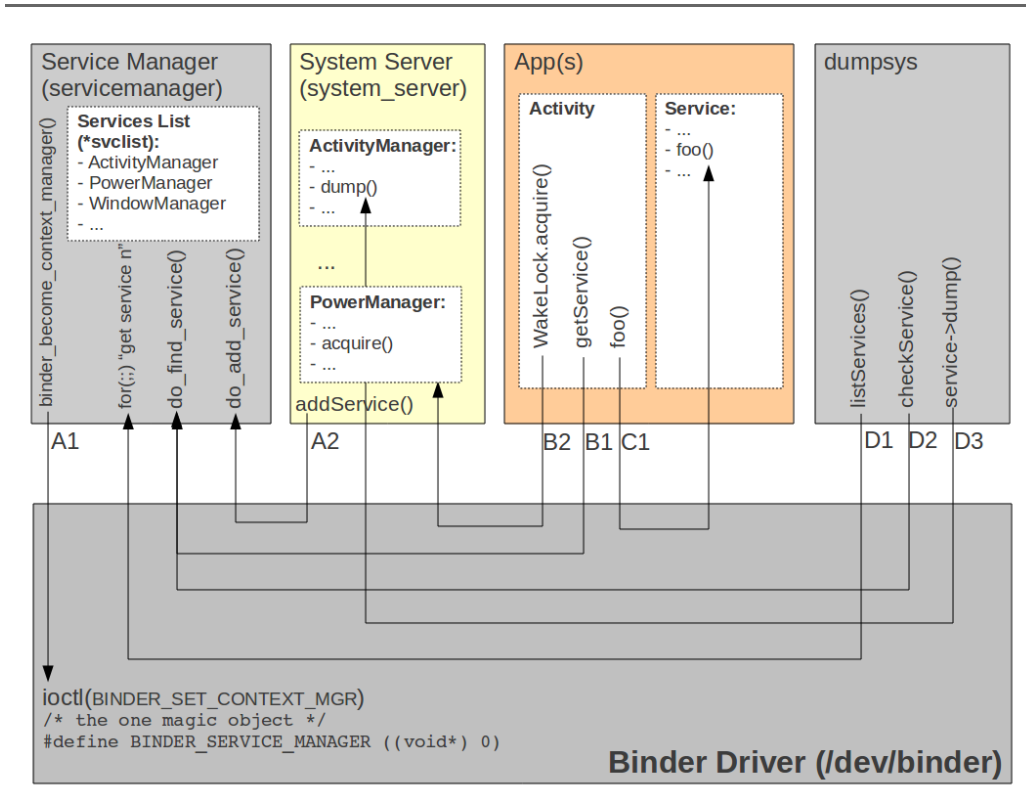

4. System Services

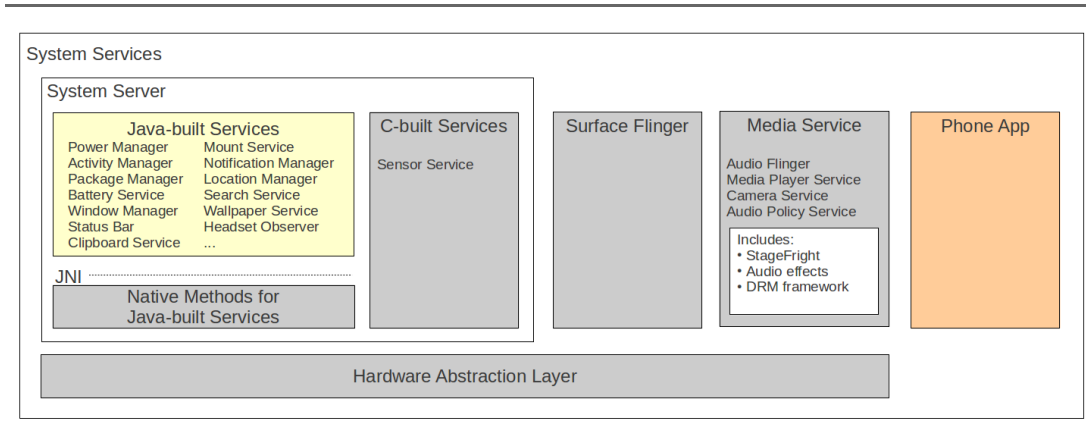

5. HAL

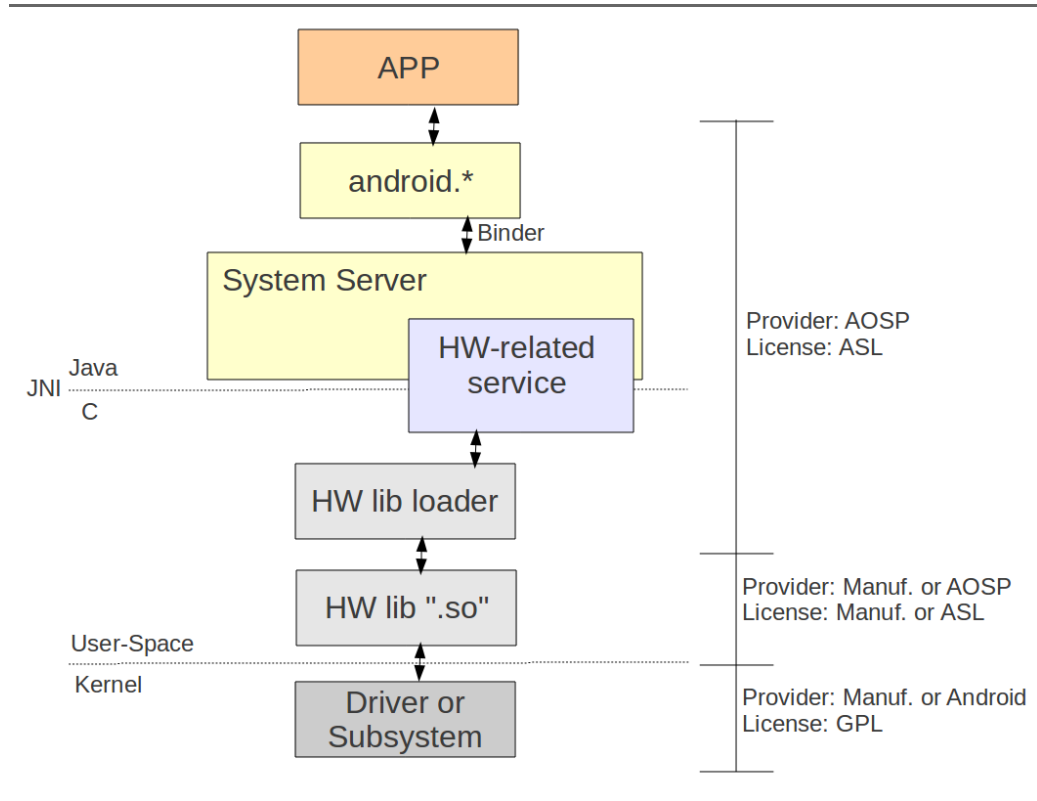

6. Call walkthrough

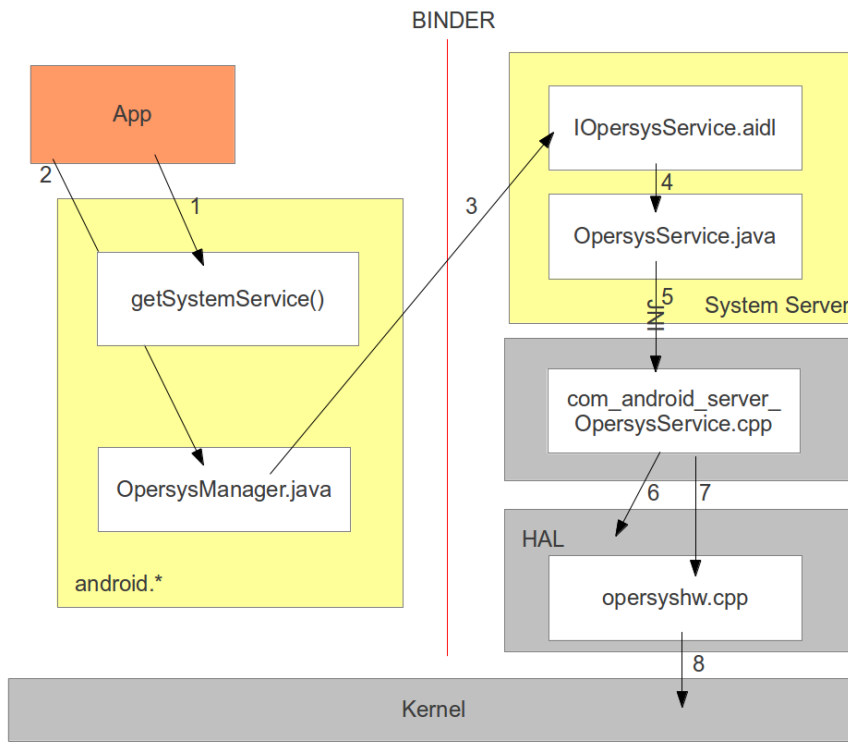

7. System startup

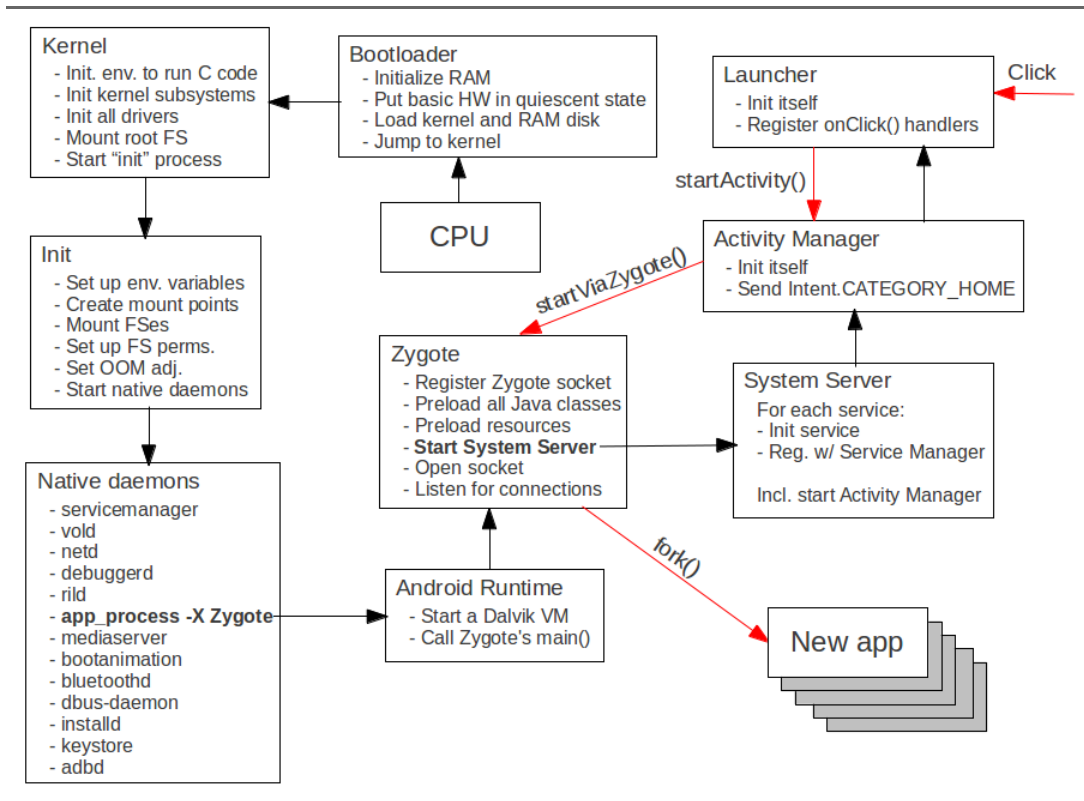

8. Debug setup

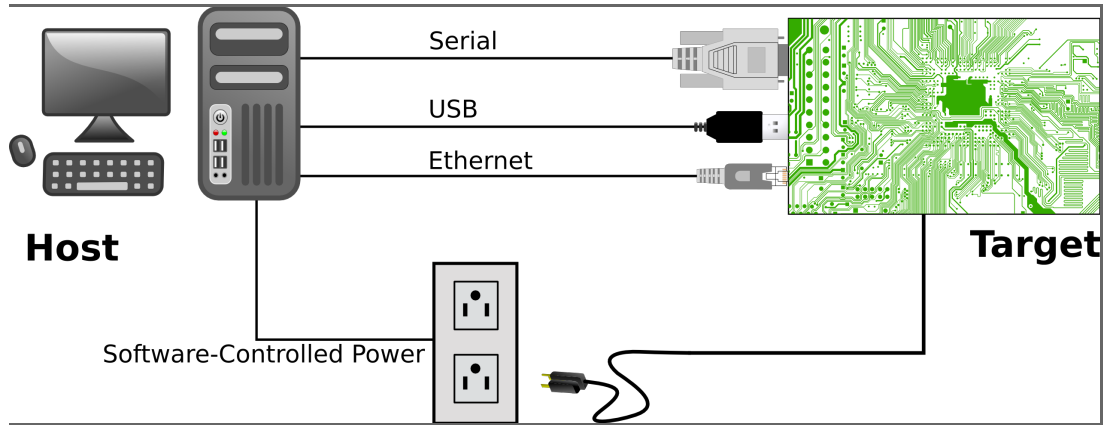

9. Network boot

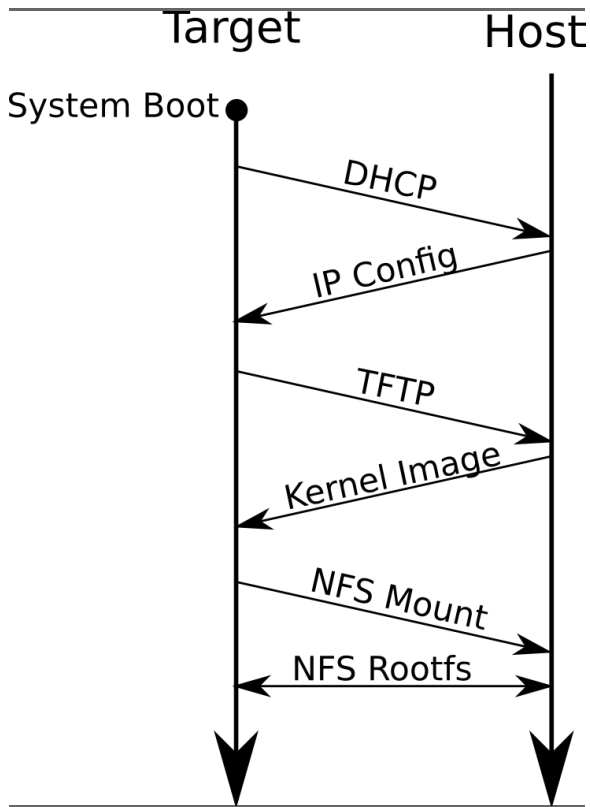

10. Symbolic debugging

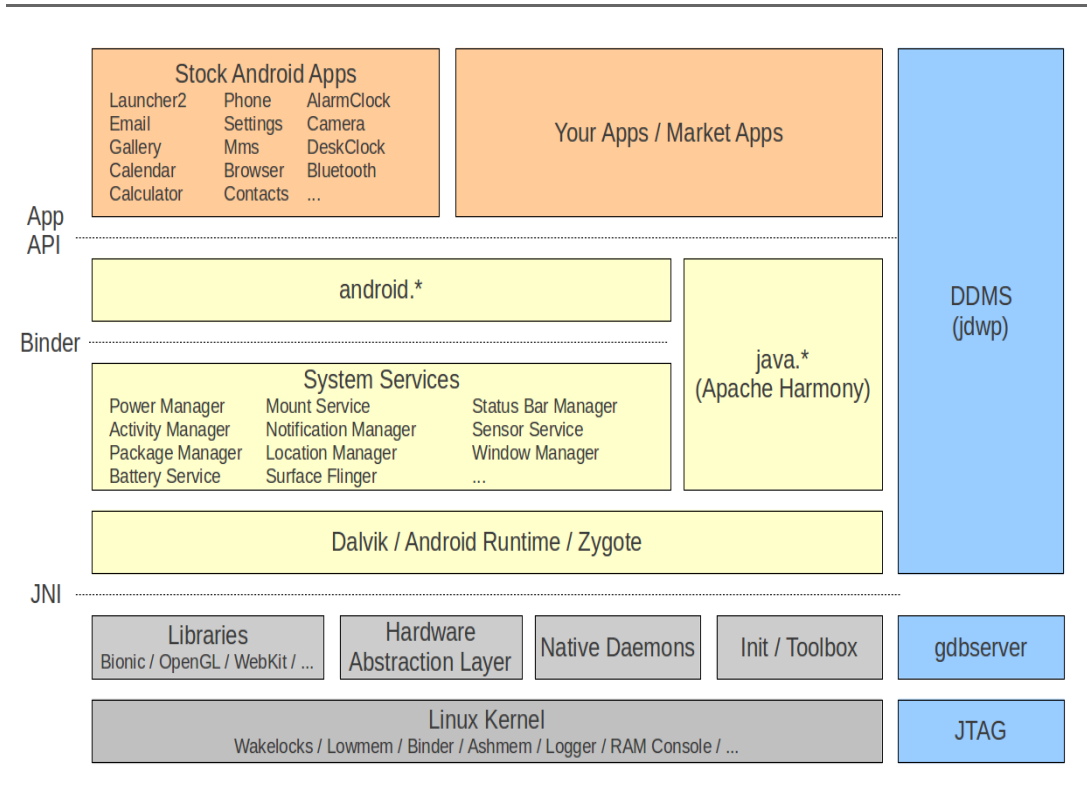

Working with the AOSP Sources

1. Basics
2. Preparing for Eclipse import
3. Importing into Eclipse
4. Fixing AOSP for Eclipse
5. Browsing the sources

1. Basics

- repo
- build/envsetup.sh
 - godir
 - croot
 - mm
 - m
 - jgrep
 - cgrep
 - resgrep
- hmm
- lunch
- make -j8

2. Preparing for Eclipse import

AOSP:

- Get AOSP ... from Google or otherwise
- Extract if needed
- Configure, build, etc.

Eclipse / ADT:

- Get ADT bundle from developer.android.com
- Extract
- Start and update and if needed

Set up basic classpath file:

```
[aosp]$ cp development/ide/eclipse/.classpath .
```

Adjust eclipse.ini:

- On my ADT bundle, it's:
adt-bundle-linux-x86_64-20130917/eclipse/eclipse.ini
- Change this:

```
-XX:MaxPermSize=256m  
-Xms40m  
-Xmx768m
```

- To this:

```
-XX:MaxPermSize=256m  
-Xms128m  
-Xmx1500m
```

3. Importing into Eclipse

- Start Eclipse
- Create new "Java project":
 - Project name = your AOSP name
 - Deselect "Use default location"
 - Location = path to your AOSP
 - Click "Next"
 - Wait a little bit ...
 - Click "Finish"
 - Wait for it to build your project (or select "Build Project")
 - ... it likely will fail ...

4. Fixing AOSP for Eclipse

- Need to fix AOSP classpath file and sources
- Fixes tend to be very AOSP-specific
- Recipe is different each time
- Sometimes fixes are trivial, sometimes they aren't
- Assuming IFC6410 BSP 1.5

- Comment out a couple of things:

```
<!--  
<classpathentry kind="src" path="packages/apps/Bluetooth/src"/>  
-->  
<!--  
<classpathentry kind="src" path="packages/apps/Camera/src"/>  
-->  
<!--  
<classpathentry kind="src" path="packages/apps/Contacts/src"/>  
--  
<!--  
<classpathentry kind="src" path="packages/apps/Gallery2/src"/>  
<classpathentry kind="src" path="packages/apps/Gallery2/src_pd"/>  
<classpathentry kind="src" path="packages/apps/Gallery2/gallerycommon/src"/>  
-->  
<!--  
<classpathentry kind="src" path="packages/apps/Phone/src"/>  
-->  
<!--  
<classpathentry kind="src" path="packages/apps/Settings/src"/>  
-->  
<!--  
<classpathentry kind="lib" path="out/target/common/obj/JAVA_LIBRARIES/google-common_intermediates/javalib.jar"/>  
<classpathentry kind="lib" path="out/target/common/obj/JAVA_LIBRARIES/gsf-client_intermediates/javalib.jar"/>  
-->
```

- Move frameworks/base/core/java/com/qualcomm/util:

```
$ cd frameworks/base/core/java/com/qualcomm/  
$ mkdir snapdragon  
$ mv util/ snapdragon/
```

- **Now: right-click on project and select "Refresh"**
- You might need to manually click on Project->Build Project
- It might still show "x" on some parts until it's done rebuilding the project

5. Browsing the Sources

- Mouse-over object type to be taken to declaration
- Browse classes through “Outline”
- Browse Call Hierarchy
- View recently viewed files (Ctrl-e)
- Many other shortcuts, see:
<http://source.android.com/source/using-eclipse.html>
- Issues:
 - Can't compile with Eclipse ... still need “make”
 - For Java only

Classifying and Analyzing Tools

- Families of tools available in Linux/Android
- Use of sampling
- Use of software breakpoints
- Use of interrupts
- Ability to understand machine code
- Ability to read into internal data structures
- Use of statistics
- Use of buffering
- Time measurement
- Limitations
- Documentation vs. capabilities

Kernel Tools and Capabilities

1. Basic interfacing
2. Instrumentation
3. Analysis tools
4. Debugging

1. Basic Interfacing

- procs
- sysfs
- configs
- debugfs
- dmesg/printk

1.1. procfs

- Mounted as /proc in Android
- Virtual filesystem maintained by kernel
- Traditionally the main way to expose internal info
- Since 2.6 it's meant for process info only
- All hardware-specific info is in sysfs instead
- Documentation/filesystems/proc.txt
- Used by a lot of tools: ps, top, uptime, etc.

1/	43/	60/	cpuinfo	net/
10/	45/	63/	crypto	pagetypeinfo
1007/	46/	64/	devices	partitions
1061/	47/	7/	diskstats	sched_debug
11/	48/	726/	dma-mappings	schedstat
12/	488/	741/	driver/	self/
13/	49/	756/	execdomains	slabinfo
14/	499/	773/	fb	softirqs
2/	5/	8/	filesystems	stat
25/	51/	835/	fs/	swaps
26/	512/	9/	interrupts	sys/
27/	52/	909/	iomem	sysrq-trigger
28/	523/	920/	ioports	sysvipc/
29/	53/	935/	irq/	timer_list
3/	54/	950/	kallsyms	tty/
30/	547/	971/	kmsg	uptime
31/	55/	988/	kpagecount	version
33/	56/	buddyinfo	kpageflags	vmallocinfo
34/	57/	bus/	loadavg	vmstat
362/	572/	cgroups	locks	yaffs
386/	58/	cmdline	meminfo	zoneinfo
39/	59/	config.gz	misc	
40/	593/	consoles	mounts	
413/	6/	cpu/	mtd	

What's in here?

- Kernel-specific info:
 - memory information (meminfo)
 - version/build (version)
 - CPU info (cpuinfo)
 - interrupt info (irq/ and interrupts)
- One directory per PID:
 - memory maps (maps)
 - command line (cmdline)
 - mem file to access memory -- ptrace
 - sched stats (sched)
 - detailed process info (status)

A lot more stuff ...

1.2. sysfs

- Mounted as `/sys` in Android
- Virtual filesystem maintained by kernel
- Main way for kernel to publish its view of HW
- Tightly tied to kernel's device object model
- Enables hotplug functionality -- used by udev
- Allows user-space to write values to kernel-exposed properties
- Documentation/filesystems/sysfs.txt

block/	class/	devices/	fs/	module/
bus/	dev/	firmware/	kernel/	power/

1.3. configfs

- Would be mounted as `/config` if needed
- Not as often used as its counterparts
- Contrary to `sysfs`:
 - Enables user-space to create objects
- Used for configuring complex kernel-side subsystems:
 - USB composite devices
 - SCSI
- `Documentation/filesystems/configfs/configfs.txt`

1.4. debugfs

- Mount as `/sys/kernel/debug`
- Free "scratch area" for all things debugging
- No fixed rules of what can or has to be done
- Used by `ftrace`
- If you need to debug a driver, use this FS
- Documentation/`filesystems/debugfs.txt`

```
bdi/          hid/          sched_features  tracing/  
binder/       memblock/     suspend_stats   wakeup_sources
```

1.5. dmesg/printk

- Meet the kernel's printf: `printk()`
- Defined: `include/linux/printk.h`

```
int printk(const char *fmt, ...);
```

- Implemented: `kernel/printk.c`
- Can lose data in cases of large output
- Widely-used throughout kernel sources
- Don't call while holding lock:
 - Has lock contention of its own

2. Instrumentation

- mcount
- tracepoints
- kprobes
- uprobes
- HW counters
- HW breakpoints

2.1. mcount

- gcc-based mechanism
- Trigger on -pg flag
- Originally-designed for gprof
- Kernel-side implemented in assembly:

```
arch/arm/kernel/entry-common.S
```

- Conditional to CONFIG_FUNCTION_TRACER
- Two possible behaviors -- CONFIG_DYNAMIC_FTRACE:
 - Hardcoded call
 - Dynamically-patched nop

2.2. Tracepoints

- Instrument your own code, for fun and profit
- In kernel:
 - Use built-in mechanism to define/use custom tracepoints
 - See

```
kernel/tracepoint.c
include/linux/tracepoint.h
include/trace/*
include/trace/events/* -- definition of all global static tracepoints
Documentation/trace/tracepoints.txt
```

- Example -- track context switches:
 - `include/trace/sched.h` uses this macro:
TRACE_EVENT(sched_switch,...
 - This results in `trace_sched_switch()` to be created
 - `kernel/sched/core.c` uses this function

- Kernel instrumentation mechanism:
 - Conditional to `CONFIG_JUMP_LABEL`
 - If enabled, uses dynamically-patched nops
 - If disabled, uses classic `if()`
 - Beware of `CONFIG_STRICT_MEMORY_RWX`
 - Probe using `register_trace_subsys_eventname()`

- In user-space:
 - Write to ftrace's buffer
 - That's what Android's atrace functionality does
 - `/sys/kernel/debug/tracing/trace_marker`
 - It's just a file
 - `open()`, `write()`, `write()`, `write()`, ...
 - Read your events as part of ftrace's output

2.3. kprobes

- Formal mechanism for dynamically adding probe points
- In mainline kernel since 2005:
 - Stems from IBM's previous work on DProbes
 - Trimmed-down version of DProbes functionality
- Requires module insertion
- Module must know insertion address/symbol
- 3 types of probes:
 - Kprobe => `register_kprobe()`
 - Jprobe => `register_jprobe()`
 - Kretprobe => `register_kretprobe()`
- Typically:
 - `module_init()` registers + provides handlers
 - `module_exit()` unregisters
- Documentation/kprobes.txt

What's a kprobe?

- Acts like a typical breakpoint
- Original instruction at destination is copied
- Breakpoint is inserted
- On hit, kprobe-registered `pre_handler` callback notified
- Copied instruction is single-stepped
- Then, kprobe-registered `post_handler` callback notified
- Execution continues at the next instruction
- Example: `samples/kprobes/kprobe_example.c`

What's a jprobe?

- It's a kprobe inserted at function entry-point
- Allows handler to inspect function's arguments
- Called function's stack is copied for inspection:
 - Only `MAX_STACK_SIZE` is copied -- 64 bytes on ARM
- Registered handler is called
- Copied stack is recopied over the original
 - `gccism`, see doc
- Example: `samples/kprobes/jprobe_example.c`

What's a kretprobe?

- Allows you to monitor function entry and exit
- kprobe inserted at function entry-point
- Return address is saved and replaced with handler
- Then `entry_handler` is called
- Function continues
- When function returns, return handler (`handler`) is called
- Example: `samples/kprobes/kretprobe_example.c`

Android support

- It's orthogonal to Android
- Kernel mechanism
- No user-space component
- No need for explicit Android support

Resources

<https://lwn.net/Articles/132196/>

<http://www.linuxforu.com/2011/04/kernel-debugging-using-kprobe-and-jprobe/>

<https://sourceware.org/systemtap/kprobes/>

2.4. uprobes

- User-space equivalent to kprobes
- Currently:
 - x86
 - PowerPC
 - ARM support coming in 3.15
 - Presently patch available from Linaro
- See:

```
kernel/events/uprobes.c  
kernel/trace/trace_uprobe.c  
Documentation/trace/uprobracer.txt
```

2.5. HW counters

- Count key HW events without SW support
- Very HW-specific:
 - Arch-specific
 - CPU-specific
- Handled by `perf`, for better or worse
- `perf` designed to measure on overflow

2.6. HW breakpoints

- Create breakpoints on memory access
- Core is also handled by perf
- kernel/events/hw_breakpoint.c
- samples/hw_breakpoint/data_breakpoint.c

3. Analysis Tools

- SystemTap
- ktap
- BPF trace
- ftrace
- LTTng
- oprofile
- perf

3.1. SystemTap

- Problem:
kprobes requires hand-crafted modules, for each probe point
- Need:
Higher-level mechanism for defining and handling probe points
- Solution:
SystemTap
- Built on kprobe mechanism
- External project from the kernel (IBM, RedHat, Intel)
- Effectively deprecates DProbes
- Full-fledged scripting language for creating/handling probes
- **HUGE** number of canned scripts for all sorts of uses
- **<https://sourceware.org/systemtap/>**

Android support

- None officially -- not in AOSP
- Maybe?:
 - <https://github.com/flipreverse/systemtap-android>
- Also: requires a compiler to build the modules ...
- See here for a good discussion of the issues ... and a diagram:
 - http://omappedia.org/wiki/Systemtap#Systemtap_and_Cross_Compilation

Resources

<https://sourceware.org/systemtap/wiki>

<https://sourceware.org/systemtap/tutorial/>

<https://sourceware.org/systemtap/tapsets/>

3.2. ktap

- Problem:
 - SystemTap requires a compiler
 - SystemTap requires loading modules
- Need:
 - Something similar to SystemTap, minus its issues
- Solution:
 - ktap
- Compiles scripts into bytecode
- Bytecode is interpreted by lua-based VM in kernel:
 - Seriously, it sounds scarier than it actually is
- Released in May 2013
- Initially positive feedback from key kernel developers
- Nack'ed by Ingo Molnar
- Aims to be the "DTrace" of Linux

Android support

- None that I know of, this is too new at this point (Jan 2014)
- Developer has embedded background so maybe ... just maybe
- Makefile doesn't seem to have "CROSS_COMPILE" prefix

Resources

<http://www.ktap.org/>

http://events.linuxfoundation.org/sites/events/files/lcjpcojp13_zhangwei.pdf

<https://github.com/ktap/ktap>

<https://lwn.net/Articles/531059/>

3.3. BPF

- "Berkeley Packet Filter"
- Bytecode for packet filtering
- In-kernel AOT/JIT
- Reuse for tracing filters
- About the BPF patches:
 - <https://lwn.net/Articles/593476/>
 - <https://lwn.net/Articles/593476/#internals>
- The BPF tracing filters:
 - <https://lwn.net/Articles/575531/>
- BPF gcc-to-bpf user-space backend:
 - https://github.com/iovisor/bpf_gcc/commit/9e7223f8f09c822ecc6e18309e89a574a23dbf63

3.4. ftrace

- Kernel function **and** event tracer
- Relies on:
 - gcc's "-pg" flag (i.e. `mcount()`)
 - Tracepoints
- `/sys/kernel/debug/tracing/`

README	options/	trace_options
available_events	per_cpu/	trace_pipe
available_tracers	printk_formats	tracing_cpumask
buffer_size_kb	saved_cmdlines	tracing_enabled
buffer_total_size_kb	set_event	tracing_max_latency
current_tracer	trace	tracing_on
events/	trace_clock	tracing_thresh
free_buffer	trace_marker	

- Documentation/tracing/ftrace.txt

Kernel configuration options to watch for:

- CONFIG_FTRACE
- CONFIG_FUNCTION_TRACER
- CONFIG_FUNCTION_GRAPH_TRACER
- CONFIG_STACK_TRACER
- CONFIG_DYNAMIC_FTRACE

Implementation - kernel/trace/

```
blktrace.c          trace_events.c      trace_output.h
ftrace.c            trace_events_filter.c trace_printk.c
Kconfig             trace_events_filter_test.h trace_probe.c
Makefile            trace_export.c      trace_probe.h
power-traces.c      trace_functions.c    trace_sched_switch.c
ring_buffer_benchmark.c trace_functions_graph.c trace_sched_wakeup.c
ring_buffer.c        trace.h               trace_selftest.c
rpm-traces.c         trace_irqsoff.c      trace_selftest_dynamic.c
trace_branch.c       trace_kdb.c           trace_stack.c
trace.c              trace_kprobe.c        trace_stat.c
trace_clock.c        trace_mmioTRACE.c     trace_stat.h
trace_entries.h      trace_nop.c           trace_syscalls.c
trace_event_perf.c   trace_output.c        trace_uprobe.c
```

Check if tracing is on:

```
# cat tracing_on  
0
```

Check which tracers are available:

```
# cat available_tracers  
blk function_graph wakeup_rt wakeup function nop
```

Check the current tracer:

```
# cat current_tracer  
nop
```

Set the current tracer:

```
# echo function > current_tracer
```

Enable tracing -- beware the space with ">":

```
# echo 1 > tracing_on
```

The raw events:

```
# ls events/*
```

Check the content of a trace:

```
# cat trace
# tracer: function
#
# entries-in-buffer/entries-written: 60028/3128571 #P:1
#
#
#          /-----> irqsoft-off
#         /-----> need-resched
#        /-----> hardirq/softirq
#       /-----> preempt-depth
#      /-----> delay
#     /----->
#
# TASK-PID  CPU#  |   |   |   |   |   |   |   |   |   |   |   |   |   |   |   |   |   |   |   |   |
#          | |   |   |   |   |   |   |   |   |   |   |   |   |   |   |   |   |   |   |   |   |
# adbd-55  [000] |...| 1075.680000: __schedule <-schedule
# adbd-55  [000] |...| 1075.680000: rcu_sched_qs <-__schedule
# adbd-55  [000] |d...| 1075.680000: deactivate_task <-__schedule
# adbd-55  [000] |d...| 1075.680000: dequeue_task <-deactivate_task
# adbd-55  [000] |d...| 1075.680000: update_rq_clock <-dequeue_task
# adbd-55  [000] |d...| 1075.680000: dequeue_task_fair <-dequeue_task
# adbd-55  [000] |d...| 1075.680000: update_curr <-dequeue_task_fair
# adbd-55  [000] |d...| 1075.680000: clear_buddies <-dequeue_task_fair
# adbd-55  [000] |d...| 1075.680000: account_entity_dequeue <-dequeue_task_fair
# ...
```

Stop tracing

```
# echo 0 > tracing_on
```

Clear a trace:

```
# echo > trace
```

Check buffer size:

```
# cat buffer_size_kb  
1408
```

Set buffer size:

```
# echo 2048 > buffer_size_kb
```

Use function graph tracer:

```
# echo function_graph > current_tracer
```

Restart tracing:

```
# echo 1 > tracing_on
```

Check graph tracer output:

```
# cat trace
# tracer: function_graph
#
# CPU DURATION FUNCTION CALLS
# | | | |
0) 0.000 us | } /* __sync_icache_dcache */
0) 0.000 us | __sync_icache_dcache();
0) 0.000 us | vm_normal_page();
0) 0.000 us | __sync_icache_dcache();
0) 0.000 us | __cond_resched();
0) 0.000 us | } /* copy_pte_range */
0) 0.000 us | } /* copy_page_range */
0) 0.000 us | cap_vm_enough_memory() {
0) 0.000 us | cap_capable();
0) 0.000 us | __vm_enough_memory();
0) 0.000 us | }
0) 0.000 us | kmem_cache_alloc();
0) 0.000 us | anon_vma_fork() {
0) 0.000 us | anon_vma_clone() {
0) 0.000 us | kmem_cache_alloc();
0) 0.000 us | mutex_lock();
0) 0.000 us | anon_vma_chain_link();
0) 0.000 us | mutex_unlock();
0) 0.000 us | }
...
```

Linux toolset

- `trace-cmd` (uses `splice()`)-- not avail. in Android
<http://git.kernel.org/cgit/linux/kernel/git/rostedt/trace-cmd.git>
- KernelShark -- not avail. in Android
<http://people.redhat.com/srostedt/kernelshark/HTML/>
- Neither of these are included in the AOSP

Support in Android

- Since 4.1 -- significant changes in 4.2
- ... **finicky** ...
- Android stack feeds events into ftrace
- Same entries in /sys/kernel/debug/tracing
- Neither `trace-cmd` nor KernelShark
- Android tools:
 - On the device: `atrace` -- native binary
 - On the host: `systrace` -- Python script
- `systrace` calls `atrace` over adb
- `systrace`-generated traces viewable w/ Chrome
 - And nothing but Chrome ... NIH?

```
# atrace --help
usage: atrace [options] [categories...]
options include:
-a appname      enable app-level tracing for a comma separated list of cmdlines
-b N           use a trace buffer size of N KB
-c            trace into a circular buffer
-k fname,...   trace the listed kernel functions
-n           ignore signals
-s N          sleep for N seconds before tracing [default 0]
-t N          trace for N seconds [default 5]
-z           compress the trace dump
--async_start  start circular trace and return immediatly
--async_dump  dump the current contents of circular trace buffer
--async_stop  stop tracing and dump the current contents of circular trace buffer
--list_categories
              list the available tracing categories
```

```
# atrace --list_categories
  gfx - Graphics
  input - Input
  view - View System
webview - WebView
  wm - Window Manager
  am - Activity Manager
  audio - Audio
  video - Video
  camera - Camera
  hal - Hardware Modules
  res - Resource Loading
  dalvik - Dalvik VM
```

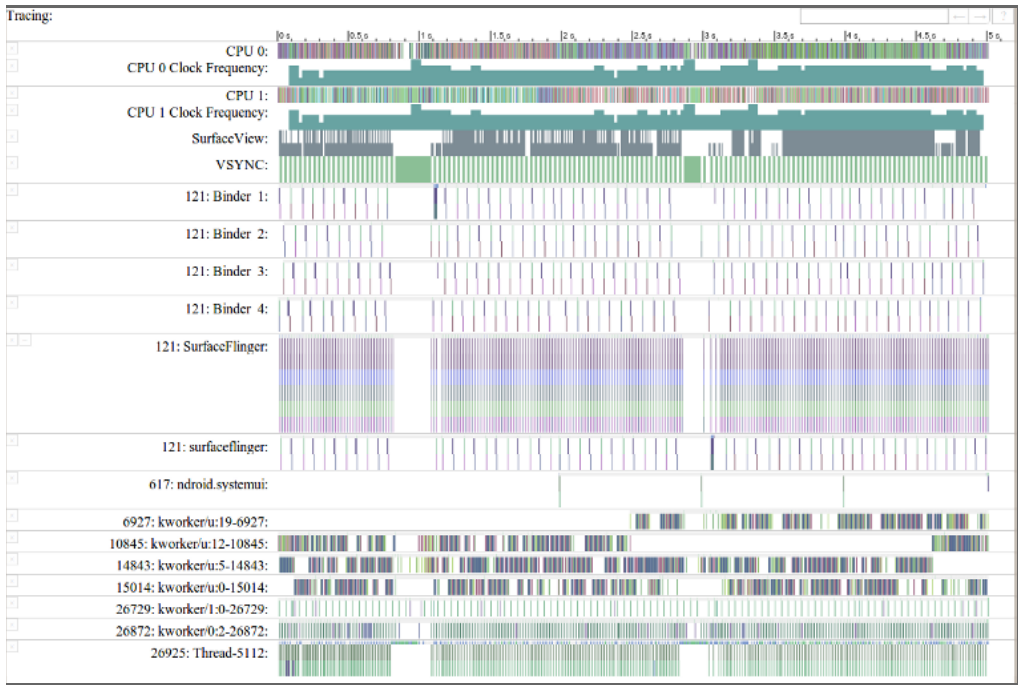

Google's doc:

<https://developer.android.com/tools/help/systrace.html>

<https://developer.android.com/tools/debugging/systrace.html>

Also have a look at these:

```
/external/chromium-trace/systrace.py
/frameworks/native/cmds/atrace
/frameworks/base/core/java/android/os/Trace.java
/frameworks/base/core/jni/android_os_Trace.cpp
/frameworks/native/include/utils/Trace.h
/system/core/include/cutils/trace.h
/system/core/libcutils/trace.c
/frameworks/native/libs/utils/Trace.cpp
```

Look for:

- ATRACE* in c/cpp files
- Trace.traceBegin()/trace.traceEnd() in Java files

- Use in C files in 4.4:

```
#include <cutils/trace.h>
...
#define ATRACE_TAG ATRACE_TAG_ALWAYS
...
ATRACE_BEGIN()
ATRACE_END()
```

- Use in C++ files -- you can also use ATRACE_CALL():

```
#include <utils/Trace.h>
...
#define ATRACE_TAG ATRACE_TAG_ALWAYS
...
ATRACE_CALL()
```

Gotchas:

- Enabling on the command line:

```
# setprop debug.atrace.tags.enableflags ...
```

- Make sure the trace marker file is writeable (/sys/kernel/debug/tracing/trace_marker):

- Either mount debugfs at startup
- Or:

```
# chmod 222 /sys/kernel/debug/tracing/trace_marker
```

Use in drivers

- In the long-term:
 - Create your own events with `TRACE_EVENT()` macro
- For short-term debugging/instrumentation:
 - Use `trace_printk()`
 - `trace_printk()` is `EXPORT_SYMBOL_GPL()`'ed
 - Make sure your module is GPL-licensed:
`MODULE_LICENSE("GPL");`
 - Otherwise, symbol will be unresolvable at load time

Resources:

<https://lwn.net/Articles/365835/>

<https://lwn.net/Articles/366796/>

<https://lwn.net/Articles/370423/>

<http://elinux.org/Ftrace>

3.5. LTTng

- Complete rewrite of the Linux Trace Toolkit
- Extremely scalable, low-overhead
- Very effective user-space tracing (UST)
- Mostly maintained out of tree:
 - Loadable module
 - Relies on existing kernel tracepoint functionality
- **<http://lttng.org/>**
- Very powerful visualization tools
- No "official" support for or in Android:
 - Scattered patches for Android support
 - User-space tracing requires SHM
- `trace_marker`-like functionality upstreamed

Resources:

<https://lwn.net/Articles/491510/>

<https://lwn.net/Articles/492296/>

3.6. oprofile

- System profiler: both kernel and user-space
- Originally based on system timer
- Relies on performance counters:
 - Most recently as provided by perf
- Must be disabled on IFC6410 for perf to work
- AOSP has oprofile tools in external/:

```
# opcontrol --help
opcontrol: usage:
--list-events  list event types
--help        this message
--verbose     show extra status
--verbose-log=lvl set daemon logging verbosity during setup
              levels are: all,sfile,arcs,samples,module,misc
--setup       setup directories
...
```

- perf seems to be favored these days
- <http://oprofile.sourceforge.net>

3.7. perf

- Initial goal: formal interface for performance counters
 - oprofile used its own custom/external module for those
- Now spans a lot events than just PMU-based
- Being pushed by fairly influential kernel developers
- Poorly documented
- Steep learning curve
- Great for statistical analysis, not for detailed tracing
- Counters saved on context switch, if per-process
- Works great on x86
- Underwhelming support for ARM SoCs
 - Actually works on IFC6410 ... with some elbow grease
- Implemented in kernel/events/ and tools/perf

- Documentation:
 - tools/perf/design.txt
 - tools/perf/Documentation/
 - <https://perf.wiki.kernel.org/index.php/Tutorial>
- **MUST READ: "multiplexing and scaling events" in tutorial:**
 - Trying to monitor more events than there PMU counters will result in multiplexing and scaling of data collection
- There's a perf system call:

```
int sys_perf_event_open(struct perf_event_attr *hw_event_uptr,  
                        pid_t pid, int cpu, int group_fd,  
                        unsigned long flags);
```

- Requires CONFIG_PERF_EVENTS
- Unlike ftrace, really can't be used without perf command

```
# perf
usage: perf [--version] [--help] COMMAND [ARGS]

The most commonly used perf commands are:
annotate      Read perf.data (created by perf record) and display annotated code
archive       Create archive with object files with build-ids found in perf.data file
bench         General framework for benchmark suites
buildid-cache Manage build-id cache.
buildid-list  List the buildids in a perf.data file
diff          Read two perf.data files and display the differential profile
evlist        List the event names in a perf.data file
inject        Filter to augment the events stream with additional information
kmem          Tool to trace/measure kernel memory(slab) properties
kvm           Tool to trace/measure kvm guest os
list          List all symbolic event types
lock          Analyze lock events
probe         Define new dynamic tracepoints
record        Run a command and record its profile into perf.data
report        Read perf.data (created by perf record) and display the profile
sched         Tool to trace/measure scheduler properties (latencies)
script        Read perf.data (created by perf record) and display trace output
stat          Run a command and gather performance counter statistics
test          Runs sanity tests.
timechart     Tool to visualize total system behavior during a workload
top           System profiling tool.

See 'perf help COMMAND' for more information on a specific command.
```

Get basic stats:

```
# perf stat -a sleep 5

Performance counter stats for 'sleep 5':

   5014.375095 task-clock           #    1.000 CPUs utilized
         371 context-switches      #    0.000 M/sec
           0 CPU-migrations        #    0.000 M/sec
          270 page-faults          #    0.000 M/sec
   49315140 cycles                  #    0.010 GHz           [80.45%]
           0 stalled-cycles-frontend #    0.00% frontend cycles idle [78.46%]
           0 stalled-cycles-backend #    0.00% backend  cycles idle [96.02%]
   16766094 instructions            #    0.34  insns per cycle   [72.67%]
   1826454  branches                #    0.364 M/sec          [76.27%]
    158411  branch-misses           #    8.67% of all branches   [76.58%]

   5.013001679 seconds time elapsed
```

Monitor what functions are using the CPU:

```
PerfTop: 935 irqs/sec kernel:91.6% exact: 0.0% [1000Hz cycles], (all, 1 CPU)
-----
```

samples	pcnt	function	DSO
13.00	34.2%	dvmAsmInstructionStart	/system/lib/libdvm.so
6.00	15.8%	strcmp	/system/lib/libc.so
6.00	15.8%	__vfprintf	/system/lib/libc.so
6.00	15.8%	dmalloc	/system/lib/libc.so
5.00	13.2%	dvmJitToInterpNoChain	/system/lib/libdvm.so
...			

See the events it can monitor:

```
# perf list

List of pre-defined events (to be used in -e):
cpu-cycles OR cycles [Hardware event]
stalled-cycles-frontend OR idle-cycles-frontend [Hardware event]
stalled-cycles-backend OR idle-cycles-backend [Hardware event]
instructions [Hardware event]
cache-references [Hardware event]
cache-misses [Hardware event]
branch-instructions OR branches [Hardware event]
branch-misses [Hardware event]
bus-cycles [Hardware event]

cpu-clock [Software event]
task-clock [Software event]
page-faults OR faults [Software event]
minor-faults [Software event]
major-faults [Software event]
context-switches OR cs [Software event]
cpu-migrations OR migrations [Software event]
alignment-faults [Software event]
emulation-faults [Software event]
```

continued:

L1-dcache-loads	[Hardware cache event]
L1-dcache-load-misses	[Hardware cache event]
L1-dcache-stores	[Hardware cache event]
L1-dcache-store-misses	[Hardware cache event]
L1-dcache-prefetches	[Hardware cache event]
L1-dcache-prefetch-misses	[Hardware cache event]
L1-icache-loads	[Hardware cache event]
L1-icache-load-misses	[Hardware cache event]
L1-icache-prefetches	[Hardware cache event]
L1-icache-prefetch-misses	[Hardware cache event]
LLC-loads	[Hardware cache event]
LLC-load-misses	[Hardware cache event]
LLC-stores	[Hardware cache event]
LLC-store-misses	[Hardware cache event]
LLC-prefetches	[Hardware cache event]
LLC-prefetch-misses	[Hardware cache event]
dTLB-loads	[Hardware cache event]
dTLB-load-misses	[Hardware cache event]
dTLB-stores	[Hardware cache event]
dTLB-store-misses	[Hardware cache event]
dTLB-prefetches	[Hardware cache event]
dTLB-prefetch-misses	[Hardware cache event]

continued:

iTLB-loads	[Hardware cache event]
iTLB-load-misses	[Hardware cache event]
branch-loads	[Hardware cache event]
branch-load-misses	[Hardware cache event]
rNNN (see 'perf list --help' on how to encode it)	[Raw hardware event descriptor]
mem:<addr>[:access]	[Hardware breakpoint]
sunrpc:rpc_call_status	[Tracepoint event]
sunrpc:rpc_bind_status	[Tracepoint event]
sunrpc:rpc_connect_status	[Tracepoint event]
...	
sched:sched_wakeup_new	[Tracepoint event]
sched:sched_switch	[Tracepoint event]
sched:sched_migrate_task	[Tracepoint event]
sched:sched_process_free	[Tracepoint event]
...	
irq:irq_handler_entry	[Tracepoint event]
irq:irq_handler_exit	[Tracepoint event]
...	

All tracepoint events can be monitored by perf

In-depth profiling of a single application

- Commands
 - `perf record -- generate`
 - `perf report -- analyze`
 - `perf annotate -- analyze`
- Samples based on PMU counter overflow (2^{64})
- They all operate on `perf.data` files
- Annotation requires compile with `-ggdb`
 - Otherwise you just get disassembly
- Annotation also requires rebuild w/ proper path to appropriate `objdump`
 - Recent versions have a `--objdump=` option
- Can record system-wide or one single process

Recording system-wide:

```
# perf record -a sleep 30
```

Reading the report:

```
# perf report
no symbols found in /system/bin/mpdecision, maybe install a debug package?
Failed to open /init, continuing without symbols
no symbols found in /system/bin/mksh, maybe install a debug package?
Failed to open /sbin/adbd, continuing without symbols
...
Kernel address maps (/proc/{kallsyms,modules}) were restricted.

Check /proc/sys/kernel/kptr_restrict before running 'perf record'.

If some relocation was applied (e.g. kexec) symbols may be unresolved.

Samples in kernel modules can't be resolved as well.
...
```

```

# Events: 15K cycles
#
# Overhead      Command      Shared Object      ...      Symbol
# .....
#
61.17%         abdb [unknown]          [k] 0xc07c5cd4
5.19%          abdb dumsys            [.] 0x1b8f8
4.52%          perf [unknown]         [k] 0xc07c3fe0
3.46%          swapper [unknown]        [k] 0xc07c5d0c
2.71%          logcat [unknown]        [k] 0xc029b0d0
2.57%          kworker/0:0 [unknown]       [k] 0xc07c5cd4
1.76%          mpdecision [unknown]       [k] 0xc029a77c
1.53%          system_server dumsys          [.] 0x3c18c
1.39%          system_server [unknown]       [k] 0xc0087710
0.63%          ls [unknown]        [k] 0xc0008578
0.51%          perf dumsys          [.] 0x25fc8
0.41%          ndroid.launcher dumsys         [.] _Z17dvmHeapBitmapWalkPK10HeapBitmapPFvP60bjectPvES4_
0.39%          d.process.media dumsys         [.] 0x39c18
0.39%          system_server dumsys         [.] 0x81740
0.37%          system_server dumsys         [.] 0x5226
0.36%          logcat dumsys         [.] 0x18f4
0.36%          system_server dumsys         [.] dvmAsmInstructionStart
0.32%          ps [unknown]       [k] 0xc07c7940
0.28%          perf dumsys         [.] dlfree
0.27%          ndroid.launcher [unknown]       [k] 0xc07c58d4
0.27%          perf dumsys         [.] memcpy
...

```

Support in Android

- perf tools in `external/linux-tools-perf`
- Will build only if `$TARGET_BUILD_VARIANT=eng`
- Otherwise the binary won't be in the AOSP
- Works the same as on the Linux command line
- `perf.data` files are automatically stored into `/data/`
- Annotation requires copying the `perf.data` file to the host
- `external/linux-tools-perf/` already patched to use cross-dev `objdump`

4. Debugging

- kgdb/kdb
- Other kernel debugging mechanisms
- JTAG

4.1. kgdb/kdb

- Built-in kernel debugger
- Two modes of operation:
 - kdb -> live analysis / peaking
 - Console/keyboard/serial
 - Magic Sysrq
 - kgdb -> source-level debugging
 - Remote gdb debugging
 - target remote ...
- "x86-centric" concept
- There's only so much you can do with this
- Documentation/DocBook/kgdb.tmpl

Internals

- Core: kernel/debug/debug_core.c
- Arch-specific code: arch/*/kernel/kgdb.c
- gdb stub: kernel/debug/gdbstub.c
- kdb front-end: kernel/debug/kdb
- kgdb I/O driver:
 - drivers/tty/serial/kgdboc.c
 - drivers/usb/early/ehci-dbgp.c
- Test suite: drivers/misc/kgdbts.c

4.2 Other kernel debugging mechanisms

- Crash dumps
 - kexec new kernel to dump-capture failed kernel
 - x86- and big-iron-centric
 - Documentation/kdump/kdump.txt
- Oops messages
 - Kernel errors/exceptions reported to dmesg
 - Documentation/oops-tracing.txt
- Dynamic debug
 - Dynamically-enable in-kernel debug info
 - Documentation/dynamic-debug-howto.txt

4.3. JTAG

- True geeks use JTAG debuggers
- See what the SoC is *really* doing
- Several vendors out there: Lauterbach, Abatron, ...
- Typically $N * \$1,000$, where $N > 2$
- Open source: Flyswater 2 (HW) + OpenOCD (SW)
- Use/operation JTAG-vendor specific
- Typical:
 - gdb-based
 - Setup file to prep processor for debug
 - Need `vmlinux` file
 - Module debugging requires relocation info

Android-Agnostic User-Space Tools

- strace
- ltrace
- LTTng UST
- apitrace
- gdb/gdbserver

5.1. strace

- Classic Unix system call tracer
- Trace system calls and signals
- Relies on `ptrace()`, `PTRACE_SYSCALL`
- Pros:
 - Detailed info
 - Very simple to use
- Cons:
 - Modifies application behavior
- Included by default on Android
- `external/strace/`
- `man strace` on Linux host

- Several modes of operation:
 - Track existing PID
 - Start and track command
 - Save output in separate file
- Recommended
 - Use the -o flag to provide output file
 - Read output file separate from command output
- **Beware:**
 - Rumor has it that AOSP-packaged one sometimes has the wrong syscall table

```
# strace -o data/logcat.strace logcat
...
# cat data/logcat.strace
execve("/system/bin/logcat", ["logcat"], [/* 14 vars */]) = 0
mprotect(0x4000f000, 4096, PROT_READ) = 0
open("/dev/null", O_RDWR) = 3
fcntl64(0, F_GETFL) = 0x2 (flags O_RDWR)
fcntl64(1, F_GETFL) = 0x2 (flags O_RDWR)
fcntl64(2, F_GETFL) = 0x2 (flags O_RDWR)
close(3) = 0
gettid() = 798
set_tls(0x40010efc, 0x40010efc, 0, 0xffffffff, 0x40010ffc) = 0
sigaction(SIGILL, {0x40000a41, [], SA_RESTART|SA_SIGINFO}, NULL, 0x2a04b038) = 0
sigaction(SIGABRT, {0x40000a41, [], SA_RESTART|SA_SIGINFO}, NULL, 0x2a04b038) = 0
sigaction(SIGBUS, {0x40000a41, [], SA_RESTART|SA_SIGINFO}, NULL, 0x2a04b038) = 0
sigaction(SIGFPE, {0x40000a41, [], SA_RESTART|SA_SIGINFO}, NULL, 0x2a04b038) = 0
sigaction(SIGSEGV, {0x40000a41, [], SA_RESTART|SA_SIGINFO}, NULL, 0x2a04b038) = 0
sigaction(SIGSTKFLT, {0x40000a41, [], SA_RESTART|SA_SIGINFO}, NULL, 0x2a04b038) = 0
sigaction(SIGPIPE, {0x40000a41, [], SA_RESTART|SA_SIGINFO}, NULL, 0x2a04b038) = 0
mmap2(NULL, 4092, PROT_READ|PROT_WRITE, MAP_PRIVATE|MAP_ANONYMOUS, 0, 0) = 0x40012000
open("/vendor/lib/liblog.so", O_RDONLY) = -1 ENOENT (No such file or directory)
open("/system/lib/liblog.so", O_RDONLY) = 3
...
```

5.2. ltrace

- Problem:
 - Sometimes need to track library calls (.so)
 - strace can only trace system calls
- Solution:
 - ltrace
- Same concept as strace but for libraries
- Inserts breakpoints at symbol entry points
- Pros:
 - Detailed info
 - Very simple to use
- Cons:
 - Modifies application behavior
- **Not** included by default in Android

Resources

- `man ltrace`
- <http://ltrace.org/> (link to git repo)
- Android port?
<https://github.com/floe/ltrace>
- <http://www.opersys.com/blog/ltrace-internals-140120>

5.3. LTTng UST

- User-space tracing mechanism for LTTng
- Provides integration with LTTng toolsuite
- Relies on SHM, which isn't exposed by Bionic
- **<http://lttng.org/ust>**
- Some Android efforts but no official support (yet)

5.4. apitrace

- "Generic" OpenGL tracing tool
- Relies on LD_PRELOAD
- No breakpoints = no behavior modification
- Records all calls to OpenGL
- Allows replay
- Has graphic analysis tools
- Some Android support upstream
- <http://apitrace.github.io/>
- <https://github.com/apitrace/apitrace>

5.5. gdb/gdbserver

- Classic user-space symbolic debugging
- For better or worse:
 - It's practically the only thing out there
- Relies on `ptrace()` for all operations
- Tightly integrated with GNU toolchain
- Use `-g` or `-ggdb` flags when building
- Several front-ends: DDD, Eclipse CDT, ...
- `man gdb`
- `gdb` also has online help in its shell
- `gdbserver` binary part of AOSP
- Everything works the same on Android

5.5.1. Target side

AOSP already takes care of debug:

- "-g" flag added to all native binaries
- Unstripped binaries in out/target/product/[PRODUCT_NAME]/symbols/...

Attaching to running process

```
# gdbserver --attach localhost:2345 30
```

Start app for debugging with gdbserver prepended

```
# gdbserver localhost:2345 service list
```

Forward the port on the host:

```
$ adb forward tcp:2345 tcp:2345
```

5.5.2. Host side

Load file **FIRST** and then attach on host side

```
$ prebuilts/gcc/linux-x86/arm/arm-eabi-4.7/bin/arm-eabi-gdb
GNU gdb (GDB) 7.3.1-gg2
Copyright (C) 2011 Free Software Foundation, Inc.
...
(gdb) file out/target/product/generic/symbols/system/bin/service
(gdb) target remote localhost:2345
(gdb) b main
Cannot access memory at address 0x0
Breakpoint 1 at 0x2a00146c: file frameworks/native/cmds/service/service.cpp, line 59.
(gdb) cont
Continuing.
warning: Could not load shared library symbols for 11 libraries, e.g. /system/bin/linker.
...
```

```
Breakpoint 1, main (argc=2, argv=0xbe882b74) at frameworks/native/cmds/service/service.cpp:59
59  {
(gdb) n
60      sp<IServiceManager> sm = defaultServiceManager();
(gdb) n
59  {
(gdb) n
60      sp<IServiceManager> sm = defaultServiceManager();
(gdb) n
61      fflush(stdout);
...
```

Also have a look at `gdbclient` command in `envsetup.sh`

Can also attach to system services' JNI code

```
$ prebuilts/gcc/linux-x86/arm/arm-eabi-4.7/bin/arm-eabi-gdb
GNU gdb (GDB) 7.3.1-gg2
Copyright (C) 2011 Free Software Foundation, Inc.
License GPLv3+: GNU GPL version 3 or later
This is free software: you are free to change and redistribute it.
There is NO WARRANTY, to the extent permitted by law. Type "show copying"
and "show warranty" for details.
This GDB was configured as "--host=x86_64-linux-gnu --target=arm-linux-android".
For bug reporting instructions, please see:
.
(gdb) target remote localhost:2345
Remote debugging using localhost:2345
0xb6f125cc in ?? ()
(gdb) set solib-search-path out/target/product/generic/symbols/system/lib/
warning: Could not load shared library symbols for 8 libraries, e.g. /system/bin/linker.
Use the "info sharedlibrary" command to see the complete listing.
Do you need "set solib-search-path" or "set sysroot"?
```

```
(gdb) b com_android_server_power_PowerManagerService.cpp:171
Breakpoint 1 at 0xaa107604: file frameworks/base/services/jni/com_android_server_power_PowerManagerService.cpp, line 171.
(gdb) cont
Continuing.
^C
Program received signal SIGINT, Interrupt.
epoll_wait () at bionic/libc/arch-arm/syscalls/epoll_wait.S:10
10      mov     r7, ip
(gdb) b com_android_server_power_PowerManagerService.cpp:161
Breakpoint 2 at 0xaa1077ba: file frameworks/base/services/jni/com_android_server_power_PowerManagerService.cpp, line 161.
...
```

Android-Specific User-Space Tools

- dumpstate / bugreport
- watchprop / getprop / setprop
- schedtop
- librank
- procmem
- procrank
- showmap
- timeinfo
- log driver / logger / logcat
- EGL trace / built-in

- tombstones
- debuggerd
- input
- ioctl
- start / stop / init "disable" flag
- notify
- run-as
- schedtest
- adb

6.1. dumpstate / bugreport

- Get a complete dump of system state
- Reads from a lot of data sources
 - logcat
 - dumphsys
 - /proc
 - etc.
- Two versions:
 - dumpstate requires root
 - bugreport doesn't require root

```
usage: dumpstate [-b soundfile] [-e soundfile] [-o file [-d] [-p] [-z]] [-s] [-q]
-o: write to file (instead of stdout)
-d: append date to filename (requires -o)
-z: gzip output (requires -o)
-p: capture screenshot to filename.png (requires -o)
-s: write output to control socket (for init)
-b: play sound file instead of vibrate, at beginning of job
-e: play sound file instead of vibrate, at end of job
-q: disable vibrate
-B: send broadcast when finished (requires -o and -p)
```

6.2. Global properties

- init process maintains set of global properties
- Can:
 - List properties: `getprop`
 - Set properties: `setprop`
 - Watch properties: `watchprop`
- Property files:
 - `/default.prop`
 - `/system/build.prop`
 - `/system/default.prop`
 - `/data/local.prop`
- Property triggers in init's `.rc` files

6.3. schedtop

- Similar to plain top
- Cumulative execution time of processes

```
schedtop [-d <delay>] [-bitamun]
-d refresh every <delay> seconds
-b batch - continous prints instead of refresh
-i hide idle tasks
-t show threads
-a use alternate screen
-m use millisecond precision
-u use microsecond precision
-n use nanosecond precision
```

Processes: 67, Threads 412

TID	EXEC_TIME	SINCE LAST	DELAY_TIME	SCHED	EXEC_TIME	DELAY_TIME	SCHED	TOTAL	NAME
1	0.000000000	0.000000000	0	0	2.280000000	0.630000000	248		/init
2	0.000000000	0.000000000	0	0	0.020000000	0.010000000	45		kthreadd
3	0.000000000	0.000000000	0	0	0.040000000	0.030000000	35		ksoftirqd/0
5	0.000000000	0.000000000	0	0	0.000000000	0.010000000	4		kworker/u:0
6	0.000000000	0.000000000	0	0	0.000000000	0.000000000	2		khelper
7	0.000000000	0.000000000	1	0	0.010000000	0.010000000	83		sync_supers
8	0.000000000	0.000000000	0	0	0.000000000	0.000000000	7		bdi-default
9	0.000000000	0.000000000	0	0	0.000000000	0.000000000	2		kblockd
10	0.000000000	0.000000000	0	0	0.000000000	0.000000000	2		rpciod
11	0.010000000	0.000000000	96	0	0.280000000	1.220000000	6700		kworker/0:1
12	0.000000000	0.000000000	0	0	0.000000000	0.000000000	3		kswapd0
...									

6.4. librank

Print library memory usage

```
Usage: librank [ -P | -L ] [ -v | -r | -p | -u | -h ]

Sort options:
-v Sort processes by VSS.
-r Sort processes by RSS.
-p Sort processes by PSS.
-u Sort processes by USS.
   (Default sort order is PSS.)
-P /path Limit libraries displayed to those in path.
-R Reverse sort order (default is descending).
-h Display this help screen.
```

RSStot	VSS	RSS	PSS	USS	Name/PID
55386K					/dev/ashmem/dalvik-heap
	29340K	29340K	23506K	23272K	com.android.systemui [645]
	13680K	13680K	7753K	7516K	com.android.launcher [765]
	11240K	11240K	5406K	5172K	system_server [565]
	7664K	7664K	1628K	1384K	com.android.phone [737]
	7552K	7552K	1521K	1280K	android.process.media [692]
	7392K	7392K	1326K	1076K	android.process.acore [818]
	7228K	7228K	1184K	940K	com.android.inputmethod.latin [710]
	7108K	7108K	1031K	784K	com.android.email [1091]
...					
40517K					anon_inode:dmabuf
	39972K	39972K	25758K	11544K	/system/bin/surfaceflinger [253]
	16172K	16172K	8142K	132K	system_server [565]
	11884K	11884K	5944K	4K	com.android.launcher [765]
	964K	964K	673K	408K	com.android.systemui [645]
	408K	0K	0K	0K	/system/bin/mediaserver [256]
	40K	0K	0K	0K	/system/bin/qseecomd [341]
19489K					/dev/ashmem/dalvik-aux-structure
	1480K	1456K	1194K	1184K	system_server [565]
	1812K	1740K	1116K	1088K	com.android.email [1091]
	1628K	1552K	1087K	1068K	com.android.phone [737]
	1824K	1740K	1076K	1044K	com.android.contacts [904]
	1656K	1572K	1050K	1028K	android.process.media [692]
	1760K	1684K	982K	944K	com.android.settings [801]
...					

6.5. procmem

See PID's memory usage

```
Usage: procmem [ -w | -W ] [ -p | -m ] [ -h ] pid
-w Displays statistics for the working set only.
-W Resets the working set of the process.
-p Sort by PSS.
-m Sort by mapping order (as read from /proc).
-h Hide maps with no RSS.
```

# procmem 565									
Vss	Rss	Pss	Uss	ShCl	ShDi	PrCl	PrDi	Name	
4K	4K	4K	4K	0K	0K	4K	0K	@	
4K	4K	0K	0K	4K	0K	0K	0K	/dev/ashmem/SurfaceFlinger	
4K	4K	2K	0K	4K	0K	0K	0K	/system/app/SettingsProvider.apk	
4K	4K	2K	0K	4K	0K	0K	0K	/system/app/SettingsProvider.apk	
0K	0K	0K	0K	0K	0K	0K	0K	/system/framework/framework_ext.jar	
8K	8K	0K	0K	8K	0K	0K	0K	/system/lib/libstagefright_yuv.so	
4K	4K	0K	0K	4K	0K	0K	0K	/system/lib/libstagefright_yuv.so	
4K	4K	4K	4K	0K	0K	4K	0K	/system/lib/libstagefright_yuv.so	
8K	8K	8K	8K	0K	0K	8K	0K	/system/app/SettingsProvider.apk	
0K	0K	0K	0K	0K	0K	0K	0K	/system/framework/core-junit.jar	
8K	8K	8K	8K	0K	0K	8K	0K	/system/framework/core-junit.jar	
32K	32K	8K	8K	24K	0K	8K	0K	/system/framework/core-junit.jar	
8K	8K	8K	8K	0K	0K	8K	0K	/dev/ashmem/dalvik-aux-structure	
64K	64K	7K	0K	64K	0K	0K	0K	/system/lib/libm.so	
0K	0K	0K	0K	0K	0K	0K	0K	/system/lib/libm.so	
4K	4K	0K	0K	4K	0K	0K	0K	/system/lib/libm.so	
16K	16K	8K	8K	8K	0K	8K	0K	/system/lib/libm.so	
0K	0K	0K	0K	0K	0K	0K	0K	/system/framework/android.policy.jar	
4K	4K	0K	0K	4K	0K	0K	0K	/system/framework/android.policy.jar	
8K	8K	8K	8K	0K	0K	8K	0K	/system/framework/android.policy.jar	
...									

6.6. procrank

See processes' memory usage, in order

```
Usage: procrank [ -W ] [ -v | -r | -p | -u | -h ]
-v Sort by VSS.
-r Sort by RSS.
-p Sort by PSS.
-u Sort by USS.
  (Default sort order is PSS.)
-R Reverse sort order (default is descending).
-w Display statistics for working set only.
-W Reset working set of all processes.
-h Display this help screen.
```

```
# procrank
PID      Vss      Rss      Pss      Uss      cmdline
565      77364K   77216K   36443K   24816K   system_server
645      63492K   63172K   31496K   28356K   com.android.systemui
253      64300K   51900K   31349K   15944K   /system/bin/surfaceflinger
765      67408K   67116K   28784K   19532K   com.android.launcher
818      35496K   35392K   7159K    5356K    android.process.acore
737      35084K   34984K   6936K    5444K    com.android.phone
254      37100K   36908K   6758K    4392K    zygote
710      34420K   34340K   6347K    4916K    com.android.inputmethod.latin
692      33404K   33236K   5879K    4644K    android.process.media
1091     32892K   32736K   5436K    4232K    com.android.email
256      9392K    8980K    5018K    4812K    /system/bin/mediaserver
904      31524K   31356K   4505K    3336K    com.android.contacts
1141     31468K   31316K   4336K    3160K    com.android.mms
1052     31676K   31508K   4252K    3064K    com.android.providers.calendar
801      31016K   30916K   4190K    2988K    com.android.settings
1230     30896K   30728K   3955K    2784K    com.android.calendar
...
```

6.7. showmap

See objects mapped to process' address space

```
showmap [-t] [-v] [-c] <pid>
-t = terse (show only items with private pages)
-v = verbose (don't coalesce maps with the same name)
-a = addresses (show virtual memory map)
```

```
# showmap 565
```

virtual size	RSS	PSS	shared clean	shared dirty	private clean	private dirty	# object
68	60	60	0	0	60	0	1 /data/dalvik-cache/system@app@SettingsProvider.apk@classes.dex
336	276	135	192	0	84	0	1 /data/dalvik-cache/system@framework@android.policy.jar@classes.dex
1348	32	1	32	0	0	0	1 /data/dalvik-cache/system@framework@apache.xml.jar@classes.dex
960	92	6	92	0	0	0	1 /data/dalvik-cache/system@framework@bouncycastle.jar@classes.dex
124	112	112	0	0	112	0	1 /data/dalvik-cache/system@framework@com.quicinc.cne.jar@classes.dex
28	12	0	12	0	0	0	1 /data/dalvik-cache/system@framework@core-junit.jar@classes.dex
3320	1848	278	1780	0	68	0	1 /data/dalvik-cache/system@framework@core.jar@classes.dex
1468	88	8	88	0	0	0	1 /data/dalvik-cache/system@framework@ext.jar@classes.dex
11156	6216	1307	5680	0	536	0	1 /data/dalvik-cache/system@framework@framework.jar@classes.dex
776	36	1	36	0	0	0	1 /data/dalvik-cache/system@framework@framework_ext.jar@classes.dex
2384	1860	1593	440	0	1420	0	1 /data/dalvik-cache/system@framework@services.jar@classes.dex
32	32	32	0	0	32	0	1 /data/data/com.android.providers.settings/databases/settings.db-shm
32	32	32	0	0	32	0	1 /data/system/locksettings.db-shm
48	32	0	0	32	0	0	1 /dev/__properties__ (deleted)
8192	16	16	0	0	0	16	4 /dev/ashmem/CursorWindow: /data/data/com.android.providers.setting
4	4	0	4	0	0	0	1 /dev/ashmem/SurfaceFlinger read-only heap (deleted)
...							

6.8. timeinfo

Report:

- realtime
- uptime
- awake percentage
- sleep percentage

```
# timeinfo  
986408 986416 100 0
```

6.9. Logger / logcat

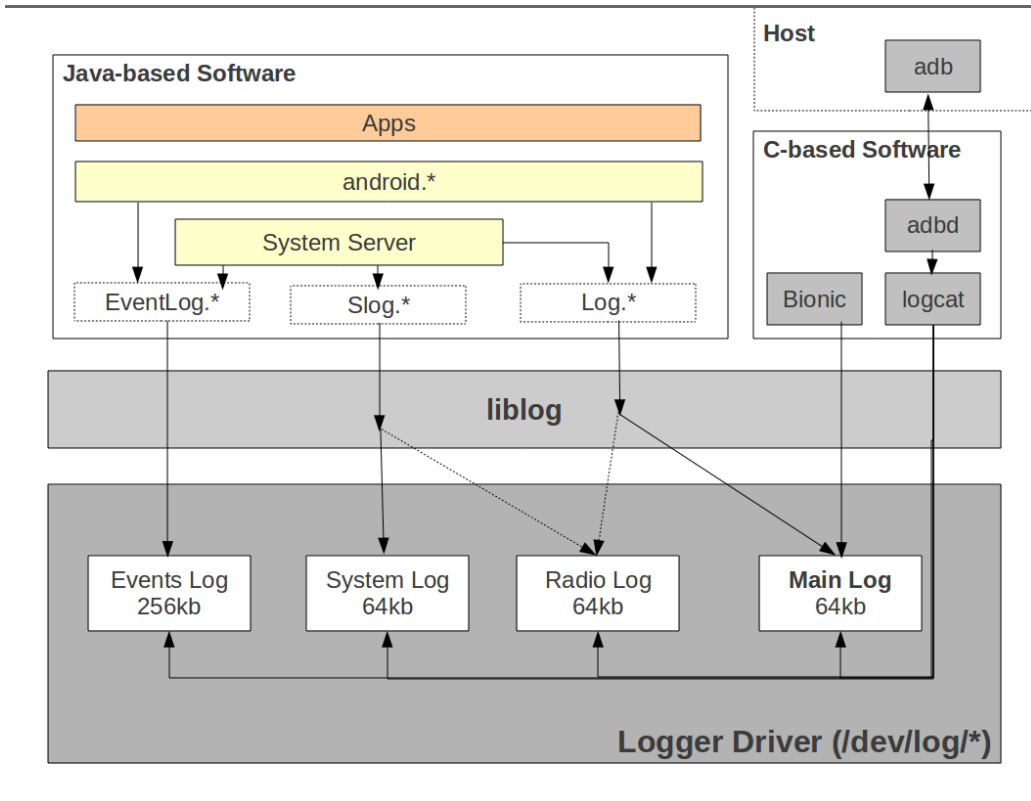

```
Usage: logcat [options] [filterspecs]
options include:
-s          Set default filter to silent.
           Like specifying filterspec '*:s'
-f <filename> Log to file. Default to stdout
-r [<kbytes>] Rotate log every kbytes. (16 if unspecified). Requires -f
-n <count>   Sets max number of rotated logs to <count>, default 4
-v <format>  Sets the log print format, where <format> is one of:

           brief process tag thread raw time threadtime long

-c          clear (flush) the entire log and exit
-d          dump the log and then exit (don't block)
-t <count>  print only the most recent <count> lines (implies -d)
-g          get the size of the log's ring buffer and exit
-b <buffer> Request alternate ring buffer, 'main', 'system', 'radio'
           or 'events'. Multiple -b parameters are allowed and the
           results are interleaved. The default is -b main -b system.
-B          output the log in binary
...
```



```
----- beginning of /dev/log/main
I/BOOT ( 150): MSM target 'msm8960', SoC 'Surf', HwID '109', SoC ver '65536'
I/qcom-bluetooth( 289): /system/etc/init.qcom.bt.sh: init.qcom.bt.sh config = onboot
I/qrngd ( 275): qrngd has started:
I/qrngd ( 275): Reading device:'/dev/hw_random' updating entropy for device:'/dev/random'
I/DMM ( 305): DMM available. movable_start_bytes at
I/DEBUG ( 251): debuggerd: Jan 10 2014 20:38:46
D/PPDaemon( 287): isHDMIPrimary: HDMI is not primary display
D/PPDaemon( 287): CABL version 1.0.20120512
I/qcom-bluetooth( 311): /system/etc/init.qcom.bt.sh: Bluetooth Address programmed successfully
----- beginning of /dev/log/system
I/Vold ( 246): Vold 2.1 (the revenge) firing up
E/PPDaemon( 287): Failed to open the config file!
D/Vold ( 246): Volume sdcard state changing -1 (Initializing) -> 0 (No-Media)
D/QSEECOMD: ( 293): qseecom listener services process entry PPID = 1
D/QSEECOMD: ( 293): Parent qseecom daemon process paused!!
D/QSEECOMD: ( 341): QSEECOM DAEMON RUNNING
D/QSEECOMD: ( 341): qseecom listener service threads starting!!!
D/QSEECOMD: ( 341): Total listener services to start = 2
D/QSEECOMD: ( 341): Init dlopen(libdrmtime.so, RTLD_NOW) succeeds
D/QSEECOMD: ( 341): Init::Init dlsym(g_FSHandle atime_start) succeeds
...
```

```
# log
USAGE: log [-p priorityChar] [-t tag] message
priorityChar should be one of:
v,d,i,w,e
```

6.10. EGL trace / built-in

For tracing the GL calls

<http://groleo.wordpress.com/2013/03/16/android-opengl-es-tracer/>

<https://developer.android.com/tools/help/gltracer.html>

6.11. tombstones

Closest thing to "core dumps"

```
# ls /data/tombstones/ -al
drwxrwx--x system system      1970-01-01 06:51 dsps
drwxrwx--x system system      1970-01-01 06:51 lpass
drwxrwx--x system system      1970-01-01 06:51 mdm
drwxrwx--x system system      1970-01-01 06:51 modem
drwxrwx--x system system      1970-01-01 06:51 wcns
```

Usually actual files are called `tombstone_XX` where `XX` is a number.

```
*** ** ** ** ** ** ** ** ** ** ** ** ** ** ** ** ** ** ** ** ** ** ** ** ** ** ** ** ** ** ** ** ** ** ** ** ** ** ** ** ** ** ** ** ** ** ** ** ** ** ** ** ** ** ** ** ** ** ** ** ** ** ** ** ** ** ** ** ** ** ** ** ** ** ** ** ** ** ** ** ** ** ** ** ** ** ** ** ** ** ** ** ** ** ** ** ** ** ** ** ** ** ** ** ** ** ** ** ** ** ** ** ** ** ** ** ** ** ** ** ** ** ** ** ** ** ** ** ** ** ** ** ** ** ** ** ** ** ** ** ** ** ** ** ** ** ** ** ** ** ** ** ** ** ** ** ** ** ** ** ** ** ** ** ** ** ** ** ** ** ** ** ** ** ** ** ** ** ** ** ** ** ** ** ** ** ** ** ** ** ** ** ** ** ****
Build fingerprint: 'Android/aosp_arm/generic:4.4/KRT16M/eng.karim.20131112.142320:eng/test-keys'
Revision: '0'
pid: 1150, tid: 1150, name: vdc >>> vdc <<<
signal 13 (SIGPIPE), code -6 (SI_TKILL), fault addr -----
r0 fffffffe r1 b7a5c028 r2 00000457 r3 00000888
r4 b6ef01a4 r5 b7a5c028 r6 00000457 r7 00000004
r8 00001000 r9 00000000 sl b6f0ee4 fp 0000000c
ip b6efe2fc sp bed41a30 lr b6ecb89f pc b6ec7178 cpsr 20000010
d0 a9c01b6937fe9a6b d1 0000000000000000
d2 0000000000000000 d3 0000000000000000
d4 0000000000000000 d5 41cbff4d35800000
d6 3f50624dd2f1a9fc d7 c1d58ff925dc7ae1
d8 0000000000000000 d9 0000000000000000
d10 0000000000000000 d11 0000000000000000
d12 0000000000000000 d13 0000000000000000
d14 0000000000000000 d15 0000000000000000
scr 00000010
...
```

```
backtrace:
#00 pc 00020178 /system/lib/libc.so (write+12)
#01 pc 0002489d /system/lib/libc.so (__sflush+54)
#02 pc 00014393 /system/lib/libc.so (fclose+54)
#03 pc 0000d939 /system/lib/libc.so
#04 pc 0000eecc /system/lib/libc.so (pthread_once+104)
#05 pc 0000db93 /system/lib/libc.so
#06 pc 00027ded /system/lib/libc.so (__cxa_finalize+156)
#07 pc 00027fe5 /system/lib/libc.so (exit+6)
#08 pc 00000b03 /system/bin/vdc
#09 pc 0000e23b /system/lib/libc.so (__libc_init+50)
#10 pc 000007f0 /system/bin/vdc

stack:
bed419f0 00000000
bed419f4 00000000
bed419f8 00000000
...
```

6.12. debuggerd

- Daemon running in background
- Allows catching crashing processes
- Set `debug.db.uid` to "greater than" UID to trigger
- Linker has code for latching to `debuggerd`

```
I/DEBUG ( 365): *****  
I/DEBUG ( 365): * Process 984 has been suspended while crashing. To  
I/DEBUG ( 365): * attach gdbserver for a gdb connection on port 5039:  
I/DEBUG ( 365): *  
I/DEBUG ( 365): * adb shell gdbserver :5039 --attach 984 &  
I/DEBUG ( 365): *  
I/DEBUG ( 365): * Press HOME key to let the process continue crashing.  
I/DEBUG ( 365): *****
```

6.13. input

Send input to input layer

```
# input
usage: input ...
       input text <string>
       input keyevent <key code number or name>
       input tap <x> <y>
       input swipe <x1> <y1> <x2> <y2>
```

6.14. ioctl

Send `ioctl()` calls to device driver

```
ioctl [-l <length>] [-a <argsize>] [-rdh] <device> <ioctlnr>
-l <length>   Length of io buffer
-a <argsize>  Size of each argument (1-8)
-r           Open device in read only mode
-d           Direct argument (no iobuffer)
-h           Print help
```

6.15. Control `init` services

- Stop service: `stop servicename`
- Start service: `start servicename`
- If no service name is specified:
 - `zygote`
 - `surfaceflinger`
- Can mark service as disabled in `.rc` files

6.16. notify

Monitor path using inotify kernel functionality (man inotify)

```
Usage: notify [-m eventmask] [-c count] [-p] [-v verbosity] path [path ...]
```

6.17. run-as

Run a command under a given package's user ID

```
Usage: run-as <package-name> <command> [<args>]
```

6.18. schedtest

Test scheduler's ability to wake processes up after 1ms

```
# schedtest
max 3449   avg 1171
max 3418   avg 1170
max 3205   avg 1167
max 2380   avg 1162
max 3449   avg 1169
max 9340   avg 1179
max 3418   avg 1168
max 3388   avg 1168
max 3418   avg 1170
max 3388   avg 1168
max 3418   avg 1167
...
```

6.19. adb

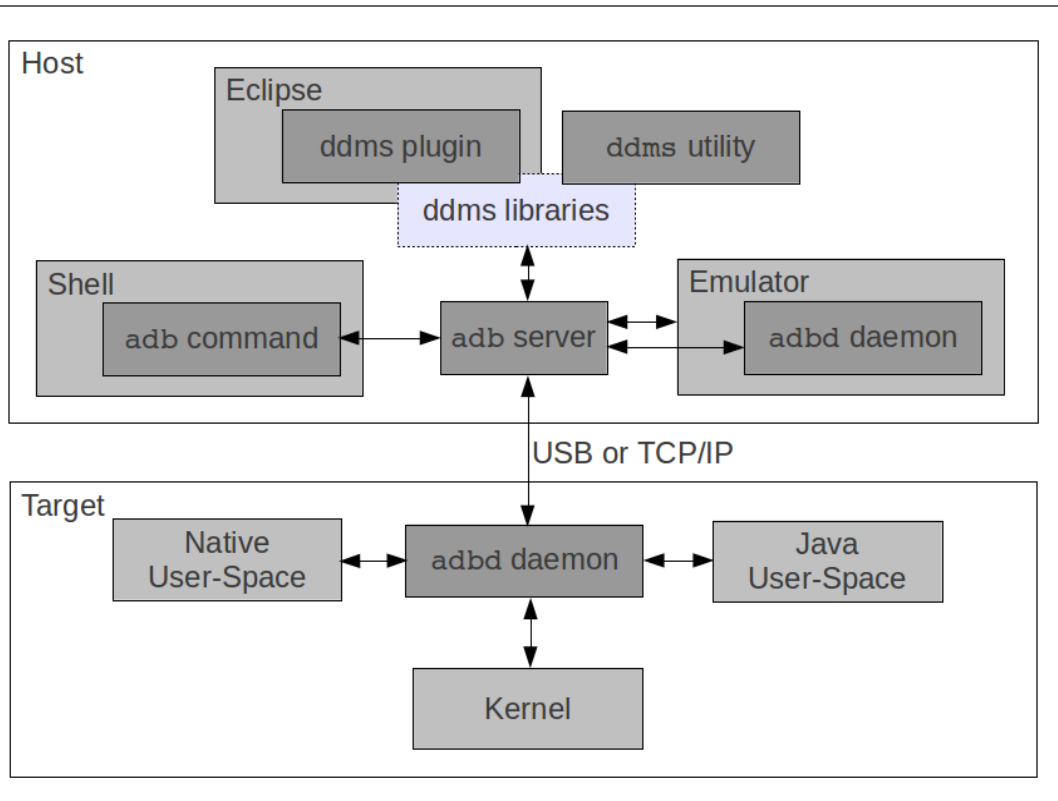

Dalvik Tools

- dalvikvm
- dvz
- app_process
- ddms
- dexdump
- jdb/jdwp
- Eclipse integration
- junit
- traceview / dmtracedump
- Memory usage analysis

7.1. dalvikvm

- Raw Dalvik VM
- Can't run Android code
- Seldom used

```
# dalvikvm -help
dalvikvm: [options] class [argument ...]
dalvikvm: [options] -jar file.jar [argument ...]

The following standard options are recognized:
-classpath classpath
-Dproperty=value
-verbose:tag ('gc', 'jni', or 'class')
-ea[:<package name>... ][:<class name>]
-da[:<package name>... ][:<class name>]
(-enableassertions, -disableassertions)
-esa
-dsa
(-enablesystemassertions, -disablesystemassertions)
-showversion
-help
...
```

7.2. dvz

Requests Zygote to start a specific class

```
# <userinput>dvz --help</userinput>
Usage: dvz [--help] [--classpath <classpath>]
       [additional zygote args] fully.qualified.java.ClassName [args]

Requests a new Dalvik VM instance to be spawned from the zygote
process. stdin, stdout, and stderr are hooked up. This process remains
while the spawned VM instance is alive and forwards some signals.
The exit code of the spawned VM instance is dropped.
```

- Not built by default
- Seldom used

7.3. app_process

- *Magic* command to start Dalvik VM with Android Runtime
- Entirely coded in C
- Used to start initial Zygote in init.rc

```
service zygote /system/bin/app_process -Xzygote /system/bin --zygote --start-system-server
```

- Also used to start a variety of Java-coded framework commands:
 - am
 - pm
 - wm
 - svc
 - monkey
 - ...

7.4. ddms

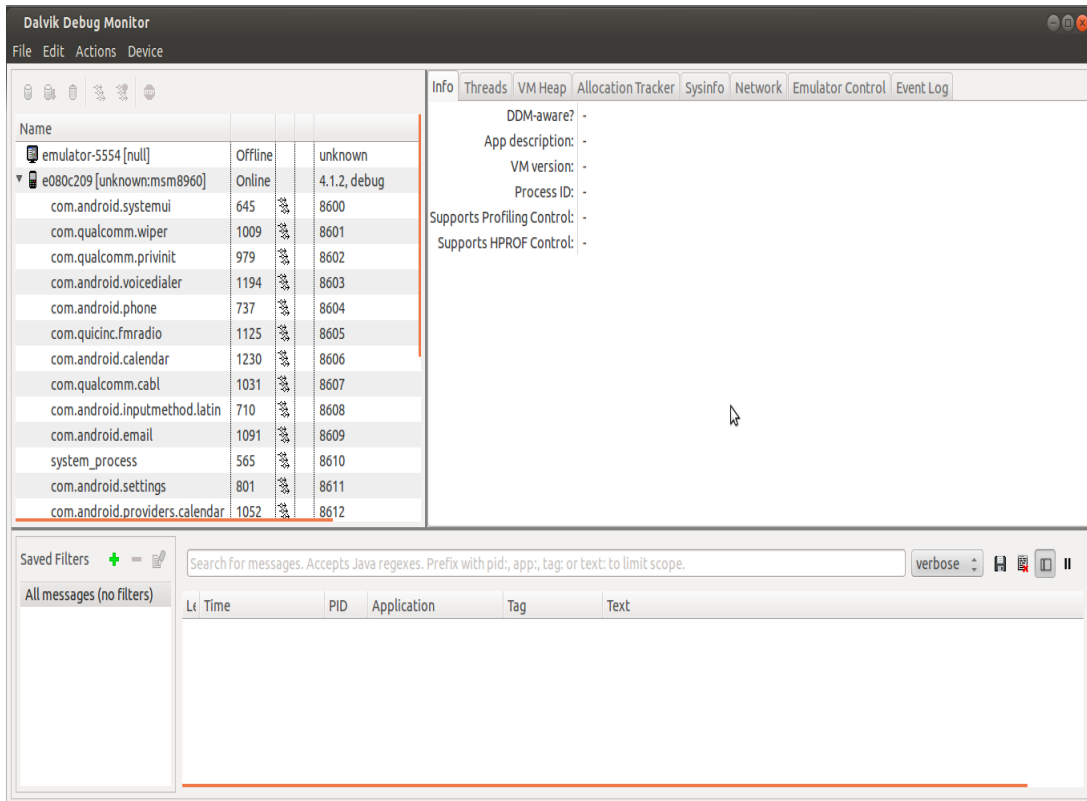

Dalvik Debug Monitor Service

- Starting Dalvik instances register with adb
- `adb jdwp` lists all such-registered processes
- `ddms` connects over adb to Dalvik processes
- Provides host-side port number allowing host-side debugger to connect to remote Dalvik process
- Can only debug Dalvik instances that start *after* adb is started:
 - Important if adb isn't started at boot time
- Recently being deprecated in favor of `monitor`
- Unfortunately, `monitor` doesn't build by default in AOSP

7.5. dexdump

Dex file disassembler

```
dexdump: [-c] [-d] [-f] [-h] [-i] [-l layout] [-m] [-t tempfile] dexfile...  
  
-c : verify checksum and exit  
-d : disassemble code sections  
-f : display summary information from file header  
-h : display file header details  
-i : ignore checksum failures  
-l : output layout, either 'plain' or 'xml'  
-m : dump register maps (and nothing else)  
-t : temp file name (defaults to /sdcard/dex-temp-*)
```

```
# dexdump /system/app/Launcher2.apk
Processing '/system/app/Launcher2.apk'...
Opened '/system/app/Launcher2.apk', DEX version '035'
Class #0
  Class descriptor : 'Landroid/support/v13/app/FragmentCompat$FragmentCompatImpl;'
  Access flags    : 0x0600 (INTERFACE ABSTRACT)
  Superclass     : 'Ljava/lang/Object;'
  Interfaces     :
  Static fields  :
  Instance fields:
  Direct methods:
  Virtual methods:
  #0
    name          : 'setMenuVisibility'
    type          : '(Landroid/app/Fragment;Z)V'
    access       : 0x0401 (PUBLIC ABSTRACT)
    code         : (none)
  ...
```

7.6. jdb/jdwp

- jdb = Java's gdb
- jdwp = Java Debug Wire Protocol
- In principle, can use jdb to debug Dalvik processes
- In practice: use Eclipse
- References:
 - <http://docs.oracle.com/javase/1.5.0/docs/guide/jpda/jdwp-spec.html>**
 - <http://docs.oracle.com/javase/7/docs/technotes/guides/jpda/jdwpTransport.html>**

7.7. Eclipse integration

- ddms/Eclipse integration
- Starting debug with Eclipse
- Debugging
- Debugging multiple processes

7.7.1. ddms/Eclipse integration

- Start ddms:
 - From the command-line (AOSP or SDK)
 - Not the one from Eclipse ("connection refused")
- It takes some time to load -- a few minutes
- Each process has a separate host-side socket
- Select the process you want to debug:
 - It'll get port 8700

- Go to Eclipse:
 - Run->Debug Configurations->Remote Java Application
 - Connection Type: "Standard (Socket Attach)"
 - Host: localhost
 - Port: 8700

7.7.2. Starting debug with Eclipse

Order is finicky:

- Start your device or emulator
- Start command-line ddms before Eclipse otherwise you'll get this in logcat:

```
"I/jdwp ( 411): Ignoring second debugger -- accepting and dropping"
```

- Start Eclipse
- Eclipse will complain that there's already a ddms running. Ignore that.

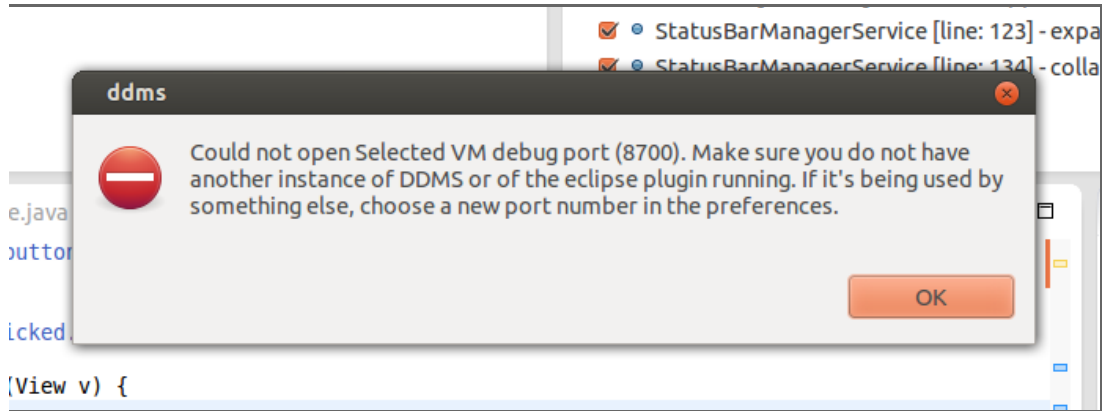

7.7.3. Debugging

- Select the process you want to debug in ddms
- Go into Eclipse and click on the debug configuration you created earlier
- Check that the little green bug is beside your process in ddms
- Again, things can look like they're freezing, this is "normal" for Eclipse ...
- Wait for Eclipse to show your Dalvik process in the "Debug" *window* in the "Debug" *view* -- all threads should show

Dalvik Debug Monitor
 File Edit Actions Device



Name			
▼ <build> [emulator-5554]	Online		<build> [4.3, debug]
system_process	275		8600 / 8700
com.android.providers.calendar	609		8601
com.android.smspush	444		8602
com.android.inputmethod.latin	371		8603
com.android.phone	396		8604
com.android.musicfx	814		8605
com.android.launcher	407		8606
android.process.media	498		8607
com.android.systemui	344		8608
com.android.mms	672		8609

7.7.4. Multiple processes

- In the debug *view* of eclipse, click on "Debug" for every time you change the process in DDMS
- Wait for that process' threads to load in the debug view
- Once threads are loaded, you can actually start debugging

7.8. junit

- Java's unit testing framework
- Used extensively in Android
- References:
 - https://developer.android.com/tools/testing/testing_android.html**
 - <http://www.vogella.com/tutorials/JUnit/article.html>**
 - <http://junit.org/>**

7.9. traceview / dmtracedump

- In-app instrumentation
- Tools to view traces;
 - traceview
 - dmtracedump
- Reference
<https://developer.android.com/tools/debugging/debugging-tracing.html>

7.10. Memory usage analysis

- Two tools:
 - ddms
 - Eclipse Memory Analyzer (MAT)
- References:
 - <http://android-developers.blogspot.com/2011/03/memory-analysis-for-android.html>
 - <http://www.vogella.com/tutorials/EclipseMemoryAnalyzer/article.html>
 - <http://www.eclipse.org/mat/>

System Services Interfacing

- dumpsys
- service (esp. “service call” and aidl files)
- am
- pm
- svc
- monkey
- ANR dumps

8.1. dumsys

- Allows you to poke system services
- Calls the system service's `dump ()` function
- By default will dump all system services

```
# dumsys
```

- Can dump just one system service

```
# dumsys statusbar
```

- C-based tool

8.2. service

- Interact with system services

```
Usage: service [-h]-?]
       service list
       service check SERVICE
       service call SERVICE CODE [i32 INT | s16 STR] ...
Options:
  i32: Write the integer INT into the send parcel.
  s16: Write the UTF-16 string STR into the send parcel.
```

- See system service's aidl file to get "CODE" and parameter list
- C-based tool

8.3. am

- Interact with the activity manager
- Allows you to send intents on the command line (very powerful)

```
# am
usage: am [subcommand] [options]
usage: am start [-D] [-W] [-P <FILE>] [--start-profiler <FILE>]
      [--R COUNT] [-S] [--opengl-trace] <INTENT>
am startservice <INTENT>
am force-stop <PACKAGE>
am kill <PACKAGE>
am kill-all
am broadcast <INTENT>
am instrument [-r] [-e <NAME> <VALUE>] [-p <FILE>] [-w]
      [--no-window-animation] <COMPONENT>
am profile start <PROCESS> <FILE>
am profile stop [<PROCESS>]
am dumpheap [flags] <PROCESS> <FILE>
...
```

8.4. pm

Interact with package manager

```
usage: pm list packages [-f] [-d] [-e] [-s] [-3] [-i] [-u] [FILTER]
pm list permission-groups
pm list permissions [-g] [-f] [-d] [-u] [GROUP]
pm list instrumentation [-f] [TARGET-PACKAGE]
pm list features
pm list libraries
pm path PACKAGE
pm install [-l] [-r] [-t] [-i INSTALLER_PACKAGE_NAME] [-s] [-f]
    [-o] [-a] [-b] [-c] [-d] [-e] [-f] [-g] [-h] [-i] [-j] [-k] [-l] [-m]
    [-n] [-o] [-p] [-q] [-r] [-s] [-t] [-u] [-v] [-w] [-x] [-y] [-z]
    [-aa] [-ab] [-ac] [-ad] [-ae] [-af] [-ag] [-ah] [-ai] [-aj] [-ak]
    [-al] [-am] [-an] [-ao] [-ap] [-aq] [-ar] [-as] [-at] [-au] [-av]
    [-aw] [-ax] [-ay] [-az] [-ba] [-bb] [-bc] [-bd] [-be] [-bf] [-bg]
    [-bh] [-bi] [-bj] [-bk] [-bl] [-bm] [-bn] [-bo] [-bp] [-bq] [-br]
    [-bs] [-bt] [-bu] [-bv] [-bw] [-bx] [-by] [-bz] [-ca] [-cb] [-cc]
    [-cd] [-ce] [-cf] [-cg] [-ch] [-ci] [-cj] [-ck] [-cl] [-cm] [-cn]
    [-co] [-cp] [-cq] [-cr] [-cs] [-ct] [-cu] [-cv] [-cw] [-cx] [-cy]
    [-cz] [-da] [-db] [-dc] [-dd] [-de] [-df] [-dg] [-dh] [-di] [-dj]
    [-dk] [-dl] [-dm] [-dn] [-do] [-dp] [-dq] [-dr] [-ds] [-dt] [-du]
    [-dv] [-dw] [-dx] [-dy] [-dz] [-ea] [-eb] [-ec] [-ed] [-ee] [-ef]
    [-eg] [-eh] [-ei] [-ej] [-ek] [-el] [-em] [-en] [-eo] [-ep] [-eq]
    [-er] [-es] [-et] [-eu] [-ev] [-ew] [-ex] [-ey] [-ez] [-fa] [-fb]
    [-fc] [-fd] [-fe] [-ff] [-fg] [-fh] [-fi] [-fj] [-fk] [-fl] [-fm]
    [-fn] [-fo] [-fp] [-fq] [-fr] [-fs] [-ft] [-fu] [-fv] [-fw] [-fx]
    [-fy] [-fz] [-ga] [-gb] [-gc] [-gd] [-ge] [-gf] [-gg] [-gh] [-gi]
    [-gj] [-gk] [-gl] [-gm] [-gn] [-go] [-gp] [-gq] [-gr] [-gs] [-gt]
    [-gu] [-gv] [-gw] [-gx] [-gy] [-gz] [-ha] [-hb] [-hc] [-hd] [-he]
    [-hf] [-hg] [-hh] [-hi] [-hj] [-hk] [-hl] [-hm] [-hn] [-ho] [-hp]
    [-hq] [-hr] [-hs] [-ht] [-hu] [-hv] [-hw] [-hx] [-hy] [-hz] [-ia]
    [-ib] [-ic] [-id] [-ie] [-if] [-ig] [-ih] [-ii] [-ij] [-ik] [-il]
    [-im] [-in] [-io] [-ip] [-iq] [-ir] [-is] [-it] [-iu] [-iv] [-iw]
    [-ix] [-iy] [-iz] [-ja] [-jb] [-jc] [-jd] [-je] [-jf] [-jg] [-jh]
    [-ji] [-jj] [-jk] [-jl] [-jm] [-jn] [-jo] [-jp] [-jq] [-jr] [-js]
    [-jt] [-ju] [-jv] [-jw] [-jx] [-jy] [-jz] [-ka] [-kb] [-kc] [-kd]
    [-ke] [-kf] [-kg] [-kh] [-ki] [-kj] [-kk] [-kl] [-km] [-kn] [-ko]
    [-kp] [-kq] [-kr] [-ks] [-kt] [-ku] [-kv] [-kw] [-kx] [-ky] [-kz]
    [-la] [-lb] [-lc] [-ld] [-le] [-lf] [-lg] [-lh] [-li] [-lj] [-lk]
    [-ll] [-lm] [-ln] [-lo] [-lp] [-lq] [-lr] [-ls] [-lt] [-lu] [-lv]
    [-lw] [-lx] [-ly] [-lz] [-ma] [-mb] [-mc] [-md] [-me] [-mf] [-mg]
    [-mh] [-mi] [-mj] [-mk] [-ml] [-mm] [-mn] [-mo] [-mp] [-mq] [-mr]
    [-ms] [-mt] [-mu] [-mv] [-mw] [-mx] [-my] [-mz] [-na] [-nb] [-nc]
    [-nd] [-ne] [-nf] [-ng] [-nh] [-ni] [-nj] [-nk] [-nl] [-nm] [-nn]
    [-no] [-np] [-nq] [-nr] [-ns] [-nt] [-nu] [-nv] [-nw] [-nx] [-ny]
    [-nz] [-oa] [-ob] [-oc] [-od] [-oe] [-of] [-og] [-oh] [-oi] [-oj]
    [-ok] [-ol] [-om] [-on] [-oo] [-op] [-oq] [-or] [-os] [-ot] [-ou]
    [-ov] [-ow] [-ox] [-oy] [-oz] [-pa] [-pb] [-pc] [-pd] [-pe] [-pf]
    [-pg] [-ph] [-pi] [-pj] [-pk] [-pl] [-pm] [-pn] [-po] [-pp] [-pq]
    [-pr] [-ps] [-pt] [-pu] [-pv] [-pw] [-px] [-py] [-pz] [-ra] [-rb]
    [-rc] [-rd] [-re] [-rf] [-rg] [-rh] [-ri] [-rj] [-rk] [-rl] [-rm]
    [-rn] [-ro] [-rp] [-rq] [-rr] [-rs] [-rt] [-ru] [-rv] [-rw] [-rx]
    [-ry] [-rz] [-sa] [-sb] [-sc] [-sd] [-se] [-sf] [-sg] [-sh] [-si]
    [-sj] [-sk] [-sl] [-sm] [-sn] [-so] [-sp] [-sq] [-sr] [-ss] [-st]
    [-su] [-sv] [-sw] [-sx] [-sy] [-sz] [-ta] [-tb] [-tc] [-td] [-te]
    [-tf] [-tg] [-th] [-ti] [-tj] [-tk] [-tl] [-tm] [-tn] [-to] [-tp]
    [-tq] [-tr] [-ts] [-tt] [-tu] [-tv] [-tw] [-tx] [-ty] [-tz] [-ua]
    [-ub] [-uc] [-ud] [-ue] [-uf] [-ug] [-uh] [-ui] [-uj] [-uk] [-ul]
    [-um] [-un] [-uo] [-up] [-uq] [-ur] [-us] [-ut] [-uu] [-uv] [-uw]
    [-ux] [-uy] [-uz] [-va] [-vb] [-vc] [-vd] [-ve] [-vf] [-vg] [-vh]
    [-vi] [-vj] [-vk] [-vl] [-vm] [-vn] [-vo] [-vp] [-vq] [-vr] [-vs]
    [-vt] [-vu] [-vv] [-vw] [-vx] [-vy] [-vz] [-wa] [-wb] [-wc] [-wd]
    [-we] [-wf] [-wg] [-wh] [-wi] [-wj] [-wk] [-wl] [-wm] [-wn] [-wo]
    [-wp] [-wq] [-wr] [-ws] [-wt] [-wu] [-wv] [-ww] [-wx] [-wy] [-wz]
    [-xa] [-xb] [-xc] [-xd] [-xe] [-xf] [-xg] [-xh] [-xi] [-xj] [-xk]
    [-xl] [-xm] [-xn] [-xo] [-xp] [-xq] [-xr] [-xs] [-xt] [-xu] [-xv]
    [-xw] [-xx] [-xy] [-xz] [-ya] [-yb] [-yc] [-yd] [-ye] [-yf] [-yg]
    [-yh] [-yi] [-yj] [-yk] [-yl] [-ym] [-yn] [-yo] [-yp] [-yq] [-yr]
    [-ys] [-yt] [-yu] [-yv] [-yw] [-yx] [-yy] [-yz] [-za] [-zb] [-zc]
    [-zd] [-ze] [-zf] [-zg] [-zh] [-zi] [-zj] [-zk] [-zl] [-zm] [-zn]
    [-zo] [-zp] [-zq] [-zr] [-zs] [-zt] [-zu] [-zv] [-zw] [-zx] [-zy]
    [-zz]
```

8.5. svc

Interact with various system services

```
Available commands:
  help  Show information about the subcommands
  power Control the power manager
  data  Control mobile data connectivity
  wifi  Control the Wi-Fi manager
  usb   Control Usb state
```

8.6. monkey

- Interact with UI
- Can take scripts

```
usage: monkey [-p ALLOWED_PACKAGE [-p ALLOWED_PACKAGE] ...]
             [-c MAIN_CATEGORY [-c MAIN_CATEGORY] ...]
             [--ignore-crashes] [--ignore-timeouts]
             [--ignore-security-exceptions]
             [--monitor-native-crashes] [--ignore-native-crashes]
             [--kill-process-after-error] [--hprof]
             [--pct-touch PERCENT] [--pct-motion PERCENT]
             [--pct-trackball PERCENT] [--pct-syskeys PERCENT]
             [--pct-nav PERCENT] [--pct-majornav PERCENT]
             [--pct-appswitch PERCENT] [--pct-flip PERCENT]
             [--pct-anyevent PERCENT] [--pct-pinchzoom PERCENT]
             [--pkg-blacklist-file PACKAGE_BLACKLIST_FILE]
```

8.7. ANR dumps

- If an app hangs, it'll generate an "Application Not Responding" event
- Info about those ANRs is dumped in files in `/data/anr`

Other Tools and Techniques

- Power management / DVFS
 - Documentation/cpu-freq/*
 - http://processors.wiki.ti.com/index.php/DVFS_User_Guide
- DS-5
 - <http://www.arm.com/products/tools/software-tools/ds-5/index.php>
- sqlite3
- Using screen overlays (a-la CPU perf by Status Bar)

glibc User-Space

- Running "standard" glibc-based code with Android
- Integrating glibc in Android filesystem
- Building glibc-linked code to run with Android
- Interfacing between a glibc-based stack and the Android-stack

See courseware at

<http://www.opersys.com/training/embedded-android>

Thank You!

karim.yagmour@opersys.com

