

# Embedded Android





These slides are made available to you under a Creative Commons Share-Alike 3.0 license. The full terms of this license are here: <https://creativecommons.org/licenses/by-sa/3.0/>

Attribution requirements and misc., PLEASE READ:

- This slide must remain as-is in this specific location (slide #2), everything else you are free to change; including the logo :-)
- Use of figures in other documents must feature the below “Originals at” URL immediately under that figure and the below copyright notice where appropriate.
- You are free to fill in the “Delivered and/or customized by” space on the right as you see fit.
- You are FORBIDDEN from using the default “About” slide as-is or any of its contents.

(C) Copyright 2010-2013, Opersys inc.

These slides created by: Karim Yaghmour

Originals at: [www.opersys.com/training/embedded-android](http://www.opersys.com/training/embedded-android)

Delivered and/or customized by

# About

- Author of:

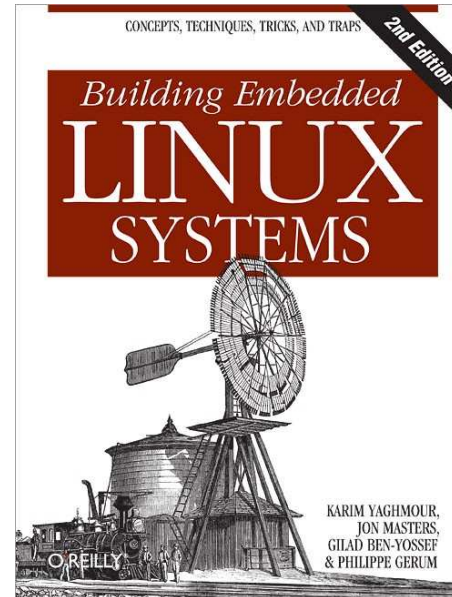
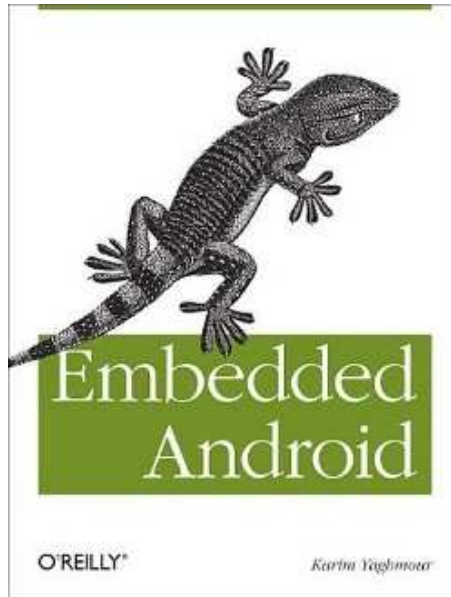

- Introduced Linux Trace Toolkit in 1999
- Originated Adeos and relayfs (kernel/relay.c)
- Training, Custom Dev, Consulting, ...

# About Android

- Huge
- Fast moving
- Stealthy

# Goals

- Master the intricacies of all components making up Android, including kernel Androidisms
- Get hands-on experience in building and customizing Android-based embedded systems
- Learn basics of Android app development
- Familiarize with the Android ecosystem

# Format

- Tracks:
  - Lecture
  - Exercises
- Fast pace
- Lots of material

# Requirements

- Embedded systems development
- C, C++
- Basic Unix/Linux command line interface experience
- Java (working knowledge of) and/or fast learner ;)

# Knowledge Fields

- Main fields:
  - Embedded systems
  - Linux kernel internals
  - Device driver development
  - Unix system administration
  - GNU software development
  - Java-based development
  - Android app development
- Vastly different fields, few (if any) master all
- Fluency required to tackle tough problems

# Topics

- Setting context:
  - Introduction to embedded Android
  - Concepts and internals
  - Android Open Source Project (AOSP)
  - Kernel basics
- Android Essentials:
  - Embedded Linux root FS
  - Native Android user-space
  - System Server
  - Hardware Abstraction Layer
  - Android Framework

- Running Code in Android
- Hacks, Variants, Tricks and Resources
- Hardware porting and support:
  - Manipulating solid-state storage devices
  - Choosing and installing the root filesystem
  - Kernel internals
  - Device driver development overview
- Additional material:
  - A quick Java introduction

- Niche topics:
  - 3rd party projects, resources and tools
  - Compatibility Test Suite

# Courseware

- These slides
- Exercises
- Android documentation:
  - [source.android.com](http://source.android.com)
  - [developer.android.com](http://developer.android.com)
  - [tools.android.com](http://tools.android.com)
- Android Open Source Project:

'Use the Source, Luke, use the Source. Be one with the code.' -- Linus Torvalds

# Hands-On Environment

- Host:
  - Ubuntu 64-bit 10.04 or 10.10
  - 10GB / AOSP (source is 4GB / AOSP)
- BeagleBone:
  - TI AM3359 (OMAP 3 / ARM Cortex A8)
  - 720MHz (when DC powered)
  - 256MB RAM
  - Boots off microSD
  - Single-cable USB/Serial/JTAG
- QEMU:
  - Same emulator used for App development
  - Originally at: [www.qemu.org](http://www.qemu.org)
  - Shipped with AOSP
  - Expandable (can create new “hardware” via .so files)
  - Has been around for a long time

# Introduction to Embedded Android

- Basics
- History
- Ecosystem
- Legal framework
- Platform and hardware requirements
- Development tools

# 1. Basics

- Features
- UX Concepts
- App Concepts

# 1.1. Features

- Application framework enabling reuse and replacement of components
- Dalvik virtual machine optimized for mobile devices
- Integrated browser based on the open source WebKit engine
- Optimized graphics powered by a custom 2D graphics library; 3D graphics based on the OpenGL ES 1.0 specification (hardware acceleration optional)
- SQLite for structured data storage
- Media support for common audio, video, and still image formats (MPEG4, H.264, MP3, AAC, AMR, JPG, PNG, GIF)
- GSM Telephony (hardware dependent)
- Bluetooth, EDGE, 3G, and WiFi (hardware dependent)
- Camera, GPS, compass, and accelerometer (hardware dependent)
- Rich development environment including a device emulator, tools for debugging, memory and performance profiling, and a plugin for the Eclipse IDE

# 1.2. UX Concepts

- Browser-like
- iPhone-ish
- No user-concept of “task”
- Main keys:
  - HOME
  - SEARCH
  - BACK
  - MENU
- App-model allows users to safely install/test almost anything



Activity

“Home”

Menu

Home

Back

“Click”

Activity #1

“Back”

“Click”

Activity #2

“Click”

“Back”

Activity #3

# 1.3. App Concepts

- No single entry point (No main() !?!?)
- Unlike Windows or Unix API/semantics in many ways
- Processes and apps will be killed at random: developer must code accordingly
- UI disintermediated from app “brains”
- Apps are isolated, very
- Behavior predicated on low-memory conditions

# 2. History

- 2002:
  - Sergey Brin and Larry Page started using Sidekick smartphone
  - Sidekick one of 1st smartphones integrating web, IM, mail, etc.
  - Sidekick was made by Danger inc., co-founded by Andy Rubin (CEO)
  - Brin/Page met Rubin at Stanford talk he gave on Sidekick's development
  - Google was default search engine on Sidekick
- 2004:
  - Despite cult following, Sidekick wasn't making \$
  - Danger inc. board decided to replace Rubin
  - Rubin left. Got seed \$. Started Android inc. Started looking for VCs.
  - Goal: Open mobile hand-set platform
- 2005 - July:
  - Got bought by Google for undisclosed sum :)
- 2007 - November:
  - Open Handset Alliance announced along with Android

- 2008 - Sept.: Android 1.0 is released
- 2009 - Feb.: Android 1.1
- 2009 - Apr.: Android 1.5 / Cupcake
- 2009 - Sept.: Android 1.6 / Donut
- 2009 - Oct.: Android 2.0/2.1 / Eclair
- 2010 - May: Android 2.2 / Froyo
- 2010 - Dec.: Android 2.3 / Gingerbread
- 2011 - Jan : Android 3.0 / Honeycomb – Tablet-optimized
- 2011 – May: Android 3.1 – USB host support
- 2011 – Nov: Android 4.0 / Ice-Cream Sandwich – merge Gingerbread and Honeycomb
- 2012 – Jun: Android 4.1 / Jelly Bean – Platform Optimization
- 2012 – Nov: Android 4.2 / Jelly Bean - Multi-user support

# 3. Ecosystem

- 1.5M phone activations per day
- 850k apps (vs. 850k for Apple's app store)
- 75% global smartphone marketshare (iOS is 17%)

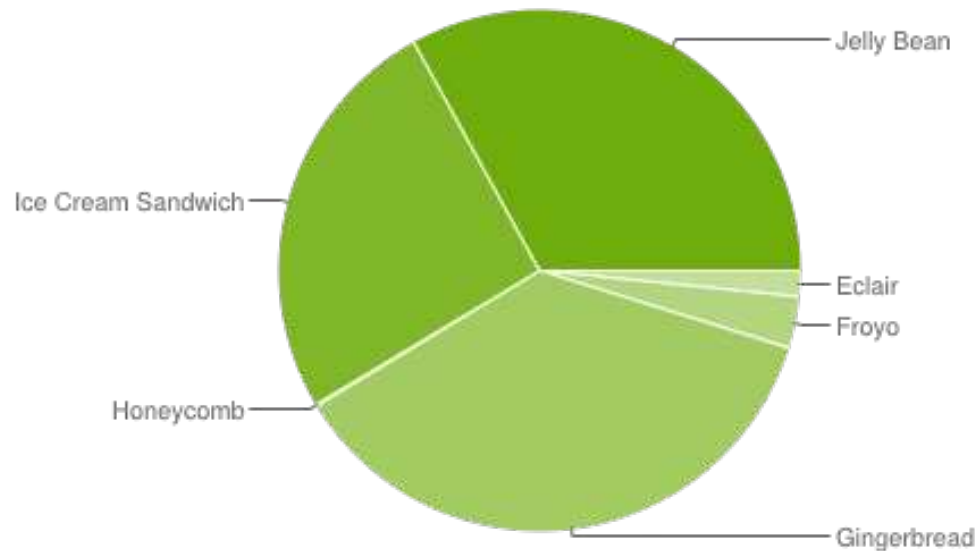

# 3.1. Who's playing?

- Leading IP:
  - Google
- Semiconductor manufacturers:
  - ARM, Intel, Freescale, TI, Qualcomm, NVIDIA, ...
- Handset manufacturers:
  - Motorola, Samsung, HTC, LG, Sony Ericsson, ...
- Tablet manufacturers:
  - Motorola, Samsung, Archos, DELL, ASUS, ...
- Special-purpose devices:
  - Nook, Joint Battle Command-Platform, ...
- App stores:
  - Android Market, Amazon App Store, V CAST Apps, B&N NOOK Apps, ...

EVERYBODY

## 3.2. Open Handset Alliance

- “... a group of 80 technology and mobile companies who have come together to accelerate innovation in mobile and offer consumers a richer, less expensive, and better mobile experience. Together we have developed Android™, the first complete, open, and free mobile platform.”
- Unclear what OHA does or what benefits, if any, members derive
- Not an organization with board members, staff, etc. ... just an “Alliance”
- Google's Android team are the lead on all bleeding edge dev, all else tag along
- OHA is largely inactive / absent
- Comprised of:
  - Mobile Operators: Sprint, T-Mobile, Vodafone, NTT Docomo, ...
  - Handset Manufacturers: HTC, Motorola, LG, Samsung, Sony Ericsson, ...
  - Semiconductor Companies: ARM, Freescale, Intel, NVIDIA, Qualcomm, TI, ...
  - Software Companies: Google, ...
  - Commercialization Companies: ...

# 4. Legal Framework

- Code access
- Code licenses
- Branding use
- Google's own Android Apps
- Alternative App stores
- Oracle v. Google

# 4.1. Code Access

- Parts:
  - Kernel
  - Android Open Source Project (AOSP)
- Kernel:
  - Should have access to latest shipped version => GPL requirement
  - Google-maintained forks at [android.googlesource.com](http://android.googlesource.com)
- AOSP:
  - *Usually* Code-drops every 6 months
  - Official AOSP branches at [android.googlesource.com](http://android.googlesource.com)
  - Managed by “repo” tool, an overlay to “git”
- Honeycomb (3.0) code required talking to Google
  - ... which hasn't precluded moders from lifting binaries off the SDK and putting Honeycomb on all sorts of devices, including B&N's Nook ...

# 4.2. Code Licenses

- Kernel:
  - GNU General Public License (a.k.a. GPL)
- AOSP:
  - Mostly Apache License 2.0 (a.k.a. ASL)
  - Having GPL-free user-space was a design goal
  - A few GPL and LGPL parts: mainly BlueZ and DBUS
  - Some key components in BSD: Bionic and Toolbox
  - “external/” directory contains a mixed bag of licenses, incl. lots of GPL
- May be desirable to add GPL/LGPL components:
  - BusyBox
  - uClibc / eglibc / glibc

# 4.3. Branding Use

- Android Robot:
  - Very much like the Linux penguin
- Android Logo (A-N-D-R-O-I-D w/ typeface):
  - Cannot be used
- Android Custom Typeface:
  - Cannot be used
- Android in Official Names:
  - As descriptor only: “for Android”
  - Most other uses require approval
- Android in Messaging:
  - Allowed if followed by a generic: “Android Application”
- Compliance through CDD/CTS involved in “approval”



# 4.4. Google's own Android Apps

- The non-AOSP apps:
  - Android Market
  - YouTube
  - Maps and Navigation
  - Gmail
  - Voice
  - SkyMap
  - ...
- Require:
  - CTS/CDD Compliance
  - Signed agreement w/ Google
- Inquiries: [android-partnerships@google.com](mailto:android-partnerships@google.com)

## 4.5. Alternative “App Stores”

- A couple of stores are already public:
  - Android Market
  - Amazon App Store
  - V CAST Apps
  - B&N NOOK Apps
  - ...
- Nothing precluding you from having your own

# 4.6. Oracle v. Google

- Filed August 2010
- Patent infringement:
  - 6,125,447; 6,192,476; 5,966,702; 7,426,720; RE38,104; 6,910,205; and 6,061,520
- Copyright infringement:
- Android does not use any Oracle Java libraries or JVM in the final product.
- Android relies on Apache Harmony and Dalvik instead.
- In October 2010, IBM left Apache Harmony to join work on Oracle's OpenJDK, leaving the project practically orphaned.
- In May 2011, judge orders claims cut from 132 to 3 and prior art references cut from hundreds to 8

# 5. Platform and Hardware requirements

- In principle:
  - Android runs on top of Linux
  - Therefore: if it runs Linux, it can run Android
- Known to have been made to work on:
  - ARM
  - x86
  - MIPS
  - SuperH
- Put in all sort of devices:
  - Washers, micro-wave ovens, car systems, etc.

# 5.1. Compliance Definition Document

- Software: MUST conform to AOSP
- Application Packaging Compatibility: support “.apk” files
- Multimedia Compatibility: decoders, encoders, recording, ...
- Developer Tool Compatibility: adb, ddms, Monkey
- Hardware compatibility:
  - Display and Graphics
  - Input Devices
  - Data Connectivity
  - Cameras
  - Memory and Storage
  - USB
- Performance Compatibility
- Security Model Compatibility
- Software Compatibility Testing
- Updatable Software: MUST include mechanism to update

# 5.2. Compatibility Test Suite

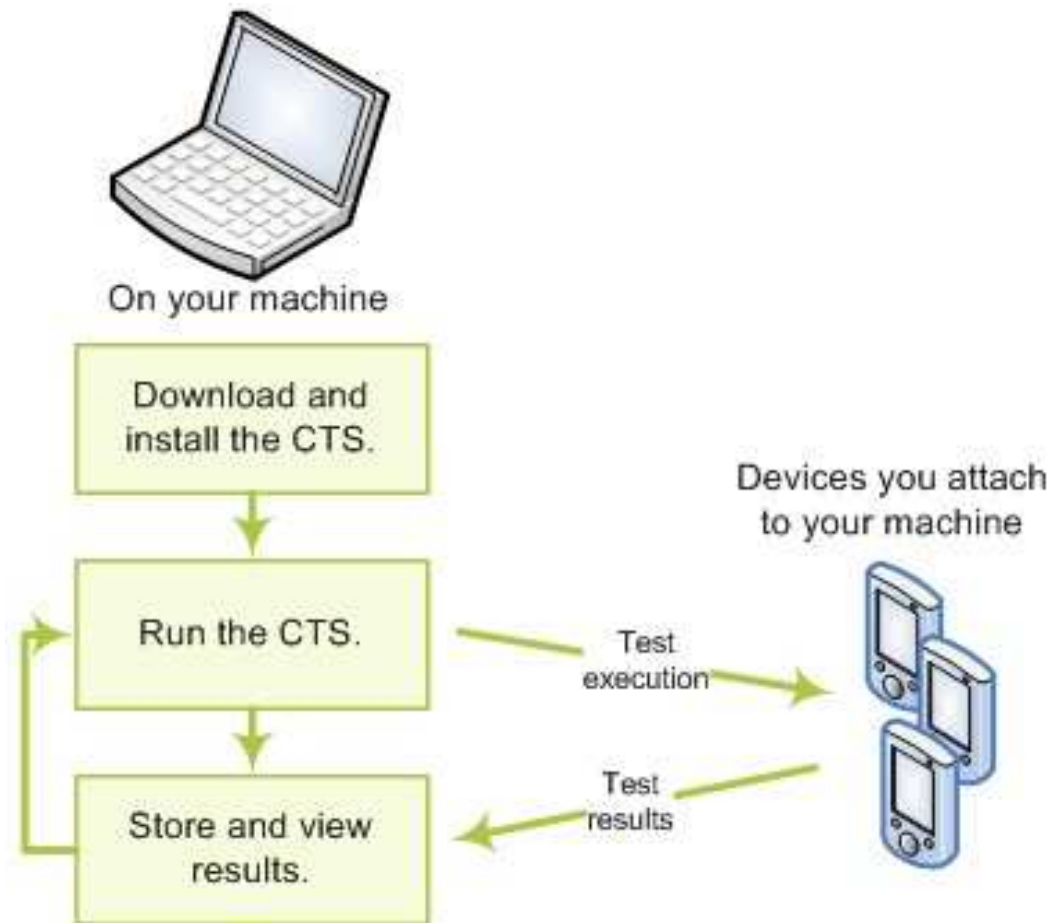

# 6. Development tools

- Requirements
- App dev tools and resources
- App debugging

# 6.1. Requirements

- App development and debugging:
  - Windows / Mac / Linux workstation
  - JDK
  - Eclipse w/ ADT plugin
  - Highly recommended: real device(**S**)
- Platform development:
  - GNU cross-dev toolchain
  - JTAG debugger
  - ... more on this later

# 6.2. App dev tools and resources

- SDK:
  - android – manage AVDs and SDK components
  - apkbuilder – creating .apk packages
  - dx – converting .jar to .dex
  - adb – debug bridge
  - ...
- Emulator – QEMU-based ARM emulator
  - Use KVM for x86 instead
- NDK: GNU toolchain for native binaries
- Documentation: [developer.android.com](http://developer.android.com)

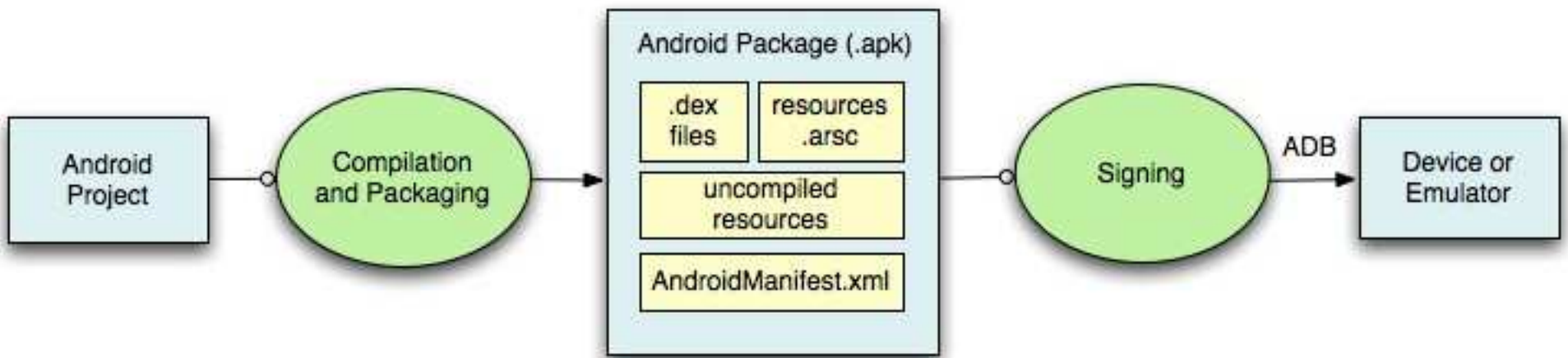

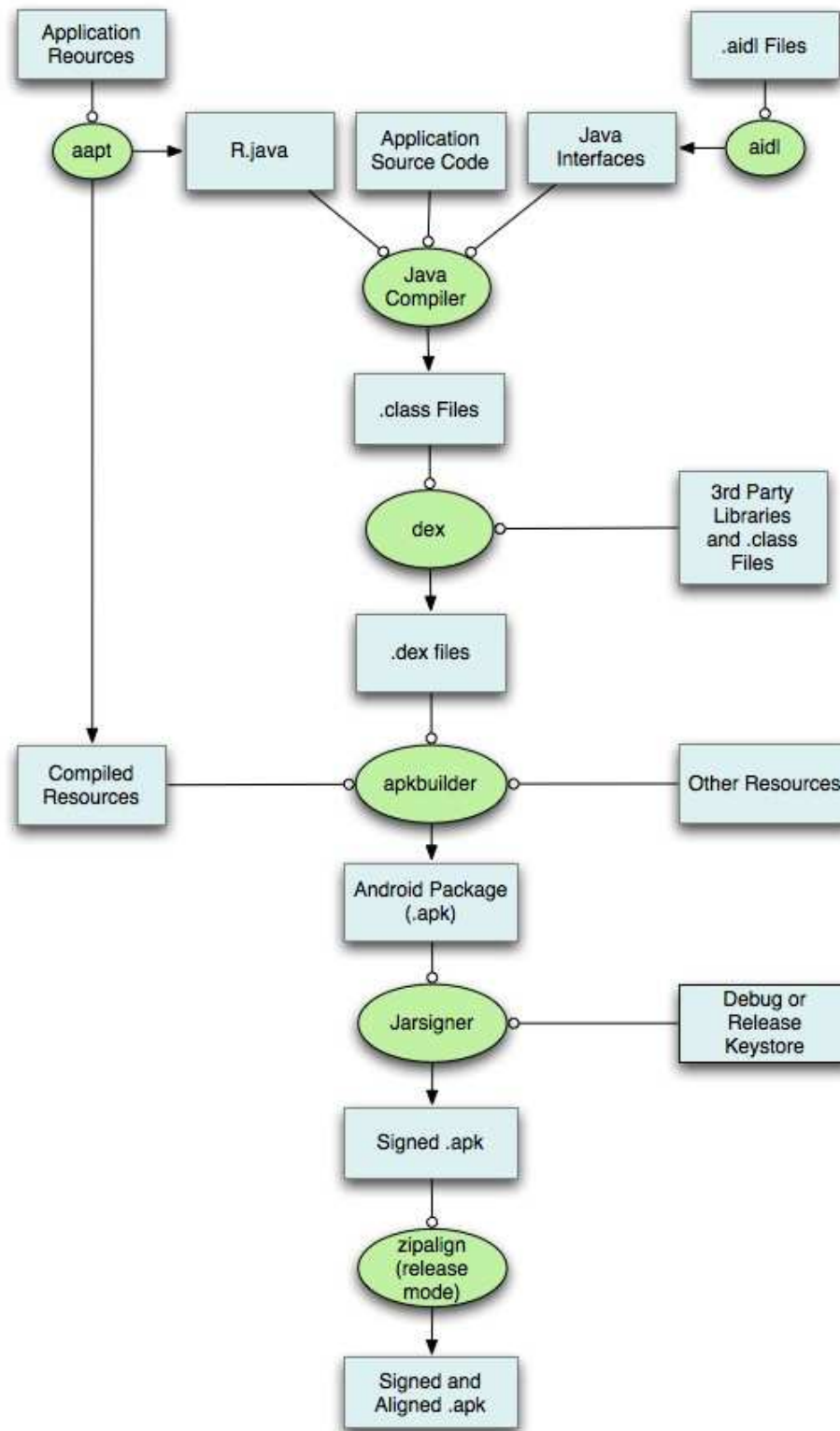

## 6.3. App debugging

- adb
- ddms
- monkeyrunner
- traceview
- logcat
- Eclipse integration (ADT plugin)

# Concepts and Internals

1. Android Concepts
2. Framework Intro
3. Overall Architecture
4. System startup
5. Linux Kernel
6. Hardware Support
7. Native User-Space
8. Dalvik
9. JNI
10. System Server
11. Calling on Services
12. Activity Manager
13. Binder
14. HAL
15. Stock AOSP Apps

# 1. Android Concepts

- Components
- Intents
- Component lifecycle
- Manifest file
- Processes and threads
- Remote procedure calls

# 1.1. Components

- 1 App = N Components
- Apps can use components of other applications
- App processes are automagically started whenever any part is needed
- Ergo: N entry points, !1, and !main()
- Components:
  - Activities
  - Services
  - Broadcast Receivers
  - Content Providers

# 1.2. Intents

- Intent = asynchronous message w/ or w/o designated target
- Like a polymorphic Unix signal, but w/o required target
- Intents “payload” held in Intent Object
- Intent Filters specified in Manifest file

# 1.3. Component lifecycle

- System automagically starts/stops/kills processes:
  - Entire system behaviour predicated on low memory
- System triggers Lifecycle callbacks when relevant
- Ergo: Must manage Component Lifecycle
- Some Components are more complex to manage than others

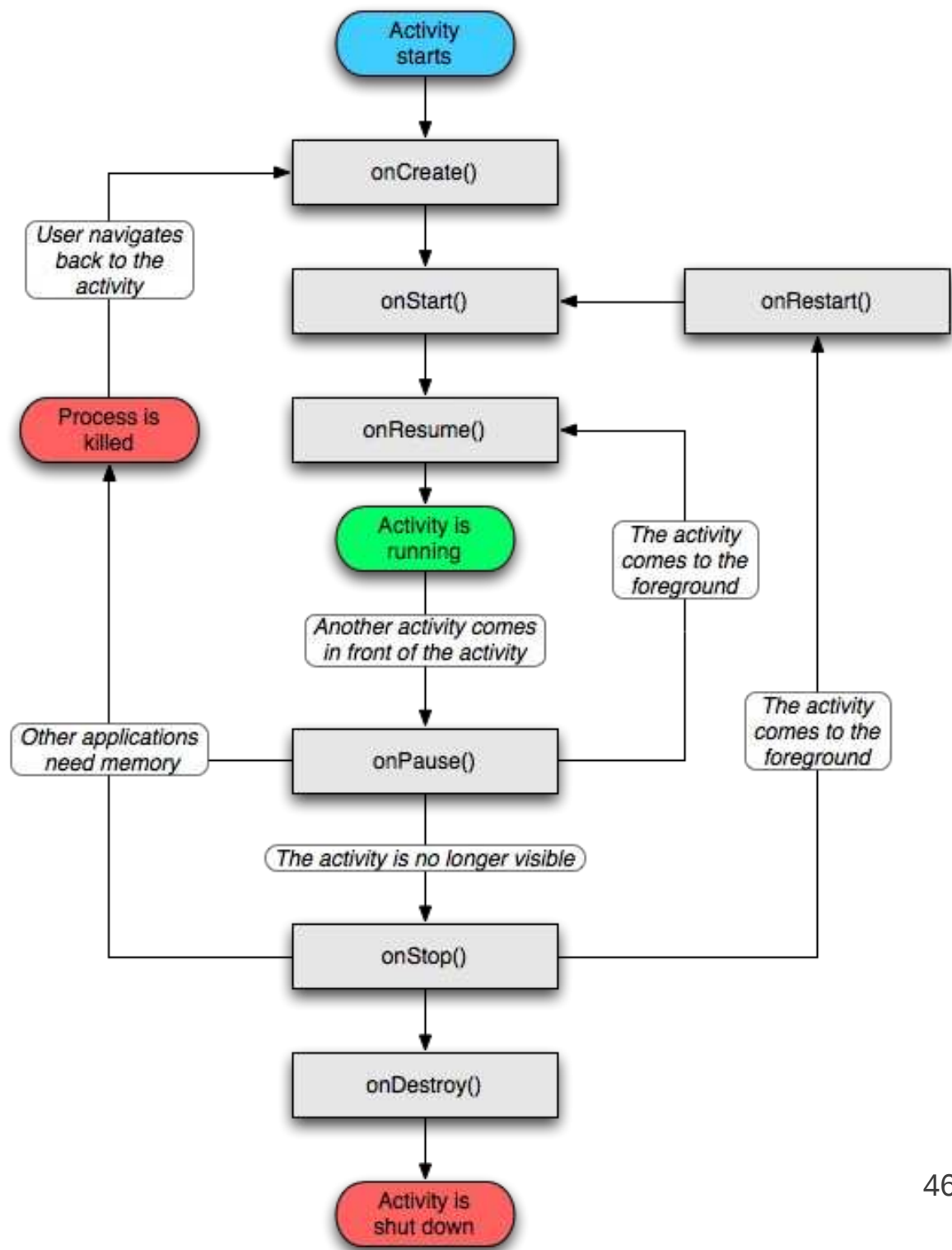

# 1.4. Manifest file

- Informs system about app's components
- XML format
- Always called AndroidManifest.xml
- Components
  - Activity = `<activity> ... static`
  - Service = `<service> ... static`
  - Broadcast Receiver:
    - Static = `<receiver>`
    - Dynamic = `Context.registerReceiver()`
  - Content Provider = `<provider> ... static`
- Intent filters

# 1.5. Processes and threads

- Processes
  - Default: all callbacks to any app Component are issued to the main process thread
  - <activity>—<service>—<recipient>—<provider> have process attribute to override default
  - Do NOT perform blocking/long operations in main process thread:
    - Spawn threads instead
  - Process termination/restart is at system's discretion
  - Therefore:
    - Must manage Component Lifecycle
- Threads:
  - Create using the regular Java Thread Object
  - Android API provides thread helper classes:
    - Looper: for running a message loop with a thread
    - Handler: for processing messages
    - HandlerThread: for setting up a thread with a message loop

# 1.6. Remote procedure calls

- Android RPCs = Binder mechanism
- No Sys V IPC due to in-kernel resource leakage
- Binder is a low-level functionality, not used as-is
- Instead: must define interface using Interface Definition Language (IDL)
- IDL fed to aidl Tool to generate Java interface definitions

# 2. Framework Introduction

- UI
- Data storage
- Security/Permissions
- ... and much more ... :
  - Graphics
  - Audio and Video
  - Location and Maps
  - Bluetooth
  - NFC

# 2.1. UI

- Everything based on hierarchy of Views and ViewGroups (layouts)
- Declared in XML or dynamically through Java
- UI components:
  - Widgets
  - Event handlers
  - Menus
  - Dialogs
  - Notifications
  - ...

## 2.2. Data storage

- Shared preferences
  - Private primitive key-pair values
- Internal storage
  - Private data on device memory
- External storage
  - Public data on shared external device (SD)
- SQLite DB
  - Private DB
- Network connection
  - Web-based storage (REST)

## 2.3. Security/Permissions

- Most security enforced at process level: UID, GID
- Permissions enforce restrictions on:
  - Per-process operations
  - Per-URI access
- Applications are sandboxed
- Specific permissions required to “exit” sandbox
- Decision to grant access based on:
  - Certificates
  - User prompts
- All permissions must be declared statically

# 2.4. Native development

- Useful for:
  - Porting existing body of code to Android
  - Developing optimized native apps, especially for gaming
- Provides:
  - Tools and build files to generate native code libraries from C/C++
  - Way to embed native libs into .apk
  - Set of stable (forward-compatible) native libs
  - Documentation, samples and tutorials
- Enables:
  - Calling native code from Java using JNI
  - Implementing fully native apps (since 2.3)
- Doesn't allow you to:
  - Compile traditional Linux/Unix apps as-is

# 3. Architecture

- Embedded Linux
- Modern phone/tablet
- System-on-Chip (SoC)
- Android

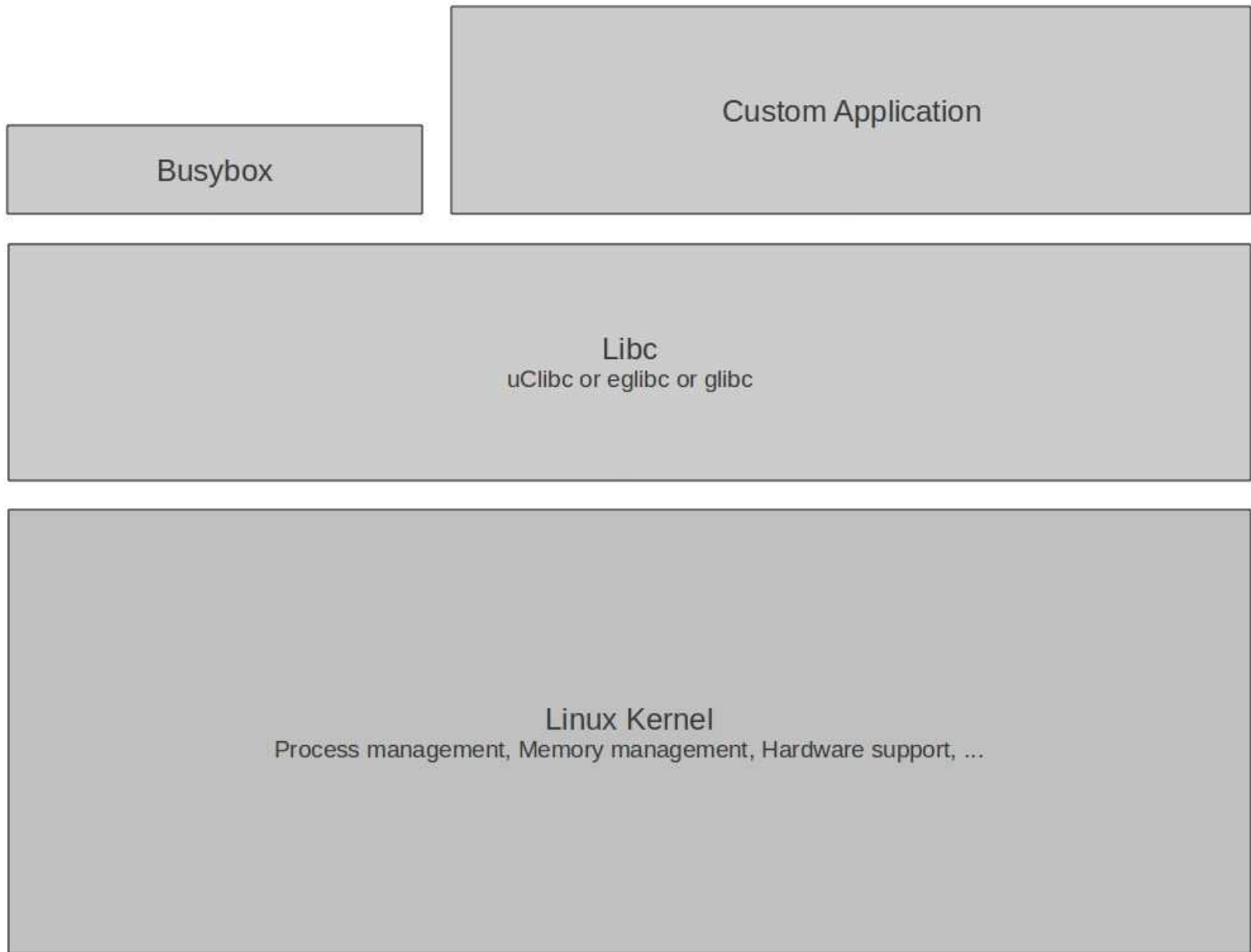

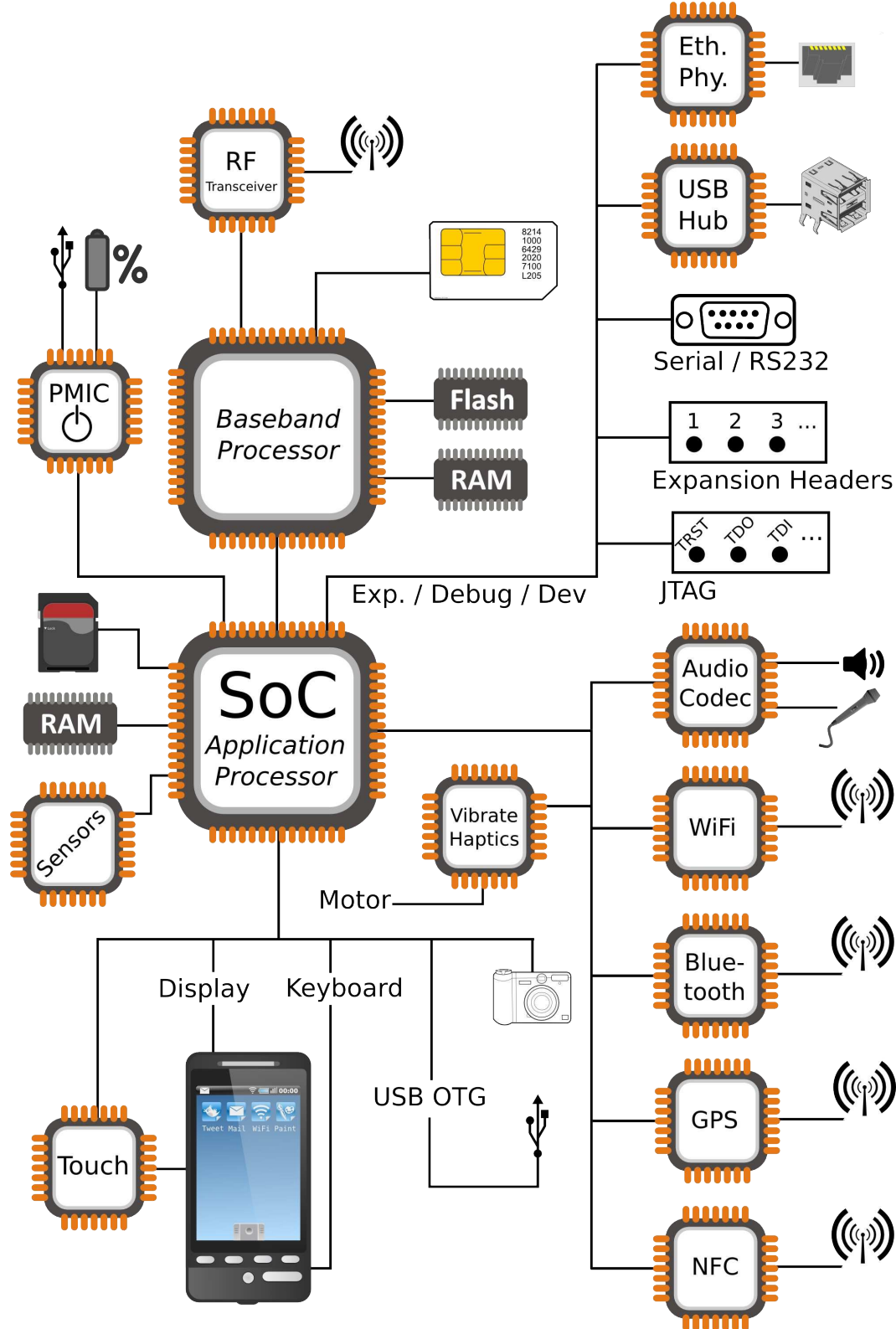

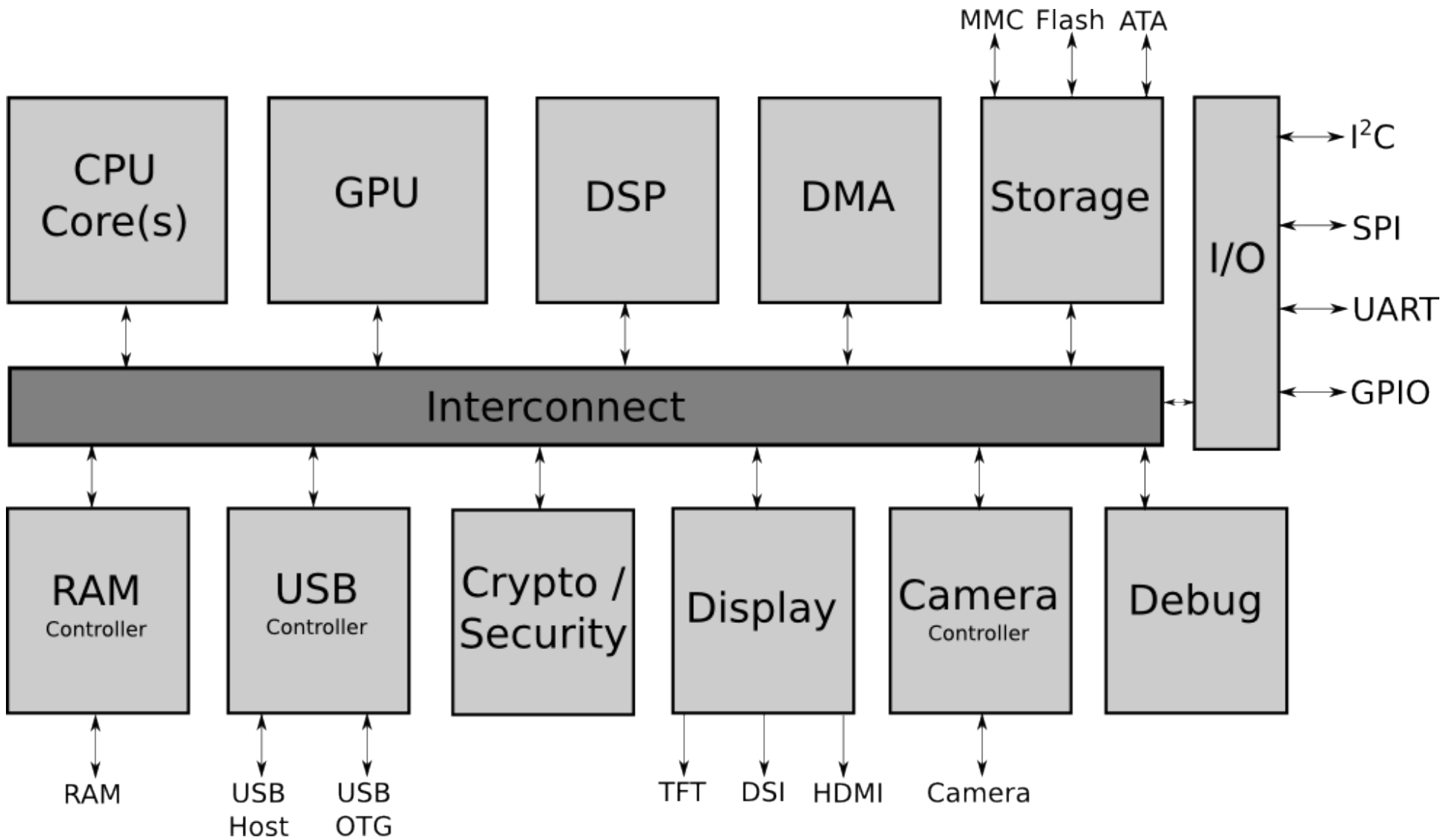

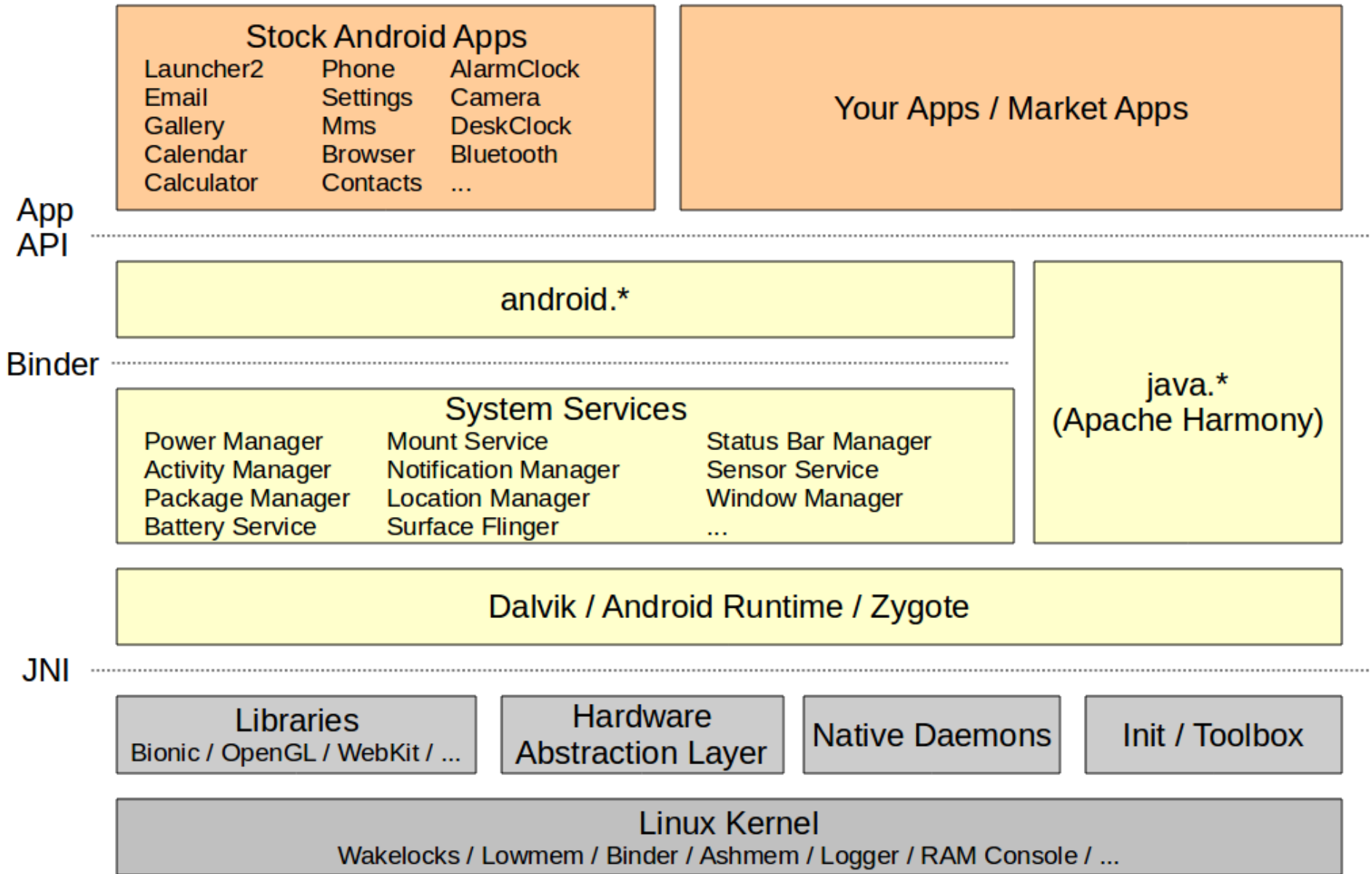

# 4. System Startup

- Bootloader
- Kernel
- Init
- Zygote
- System Server
- Activity Manager
- Launcher (Home)

# 4.1. Bootloader

- aosp/bootable/bootloader
  - Custom bootloader for Android
  - USB-based
  - Implements the “fastboot” protocol
  - Controlled via “fastboot” cli tool on host
- aosp/bootable/recovery
  - UI-based recovery boot program
  - Accessed through magic key sequence at boot
  - Usually manufacturer specific variant

- Flash layout:

0x000003860000-0x000003900000	:	"misc"		
0x000003900000-0x000003e00000	:	"recovery"		
0x000003e00000-0x000004300000	:	"boot"	←	Kernel
0x000004300000-0x00000c300000	:	"system"	←	/system
0x00000c300000-0x0000183c0000	:	"userdata"	←	/data
0x0000183c0000-0x00001dd20000	:	"cache"	←	/cache
0x00001dd20000-0x00001df20000	:	"kpanic"		
0x00001df20000-0x00001df60000	:	"dinfo"		
0x00001df60000-0x00001dfc0000	:	"setupdata"		
0x00001dfc0000-0x00001e040000	:	"splash1"		
0x000000300000-0x000001680000	:	"modem"		

From Acer Liquid-E

## 4.2. Kernel

- Early startup code is very hardware dependent
- Initializes environment for the running of C code
- Jumps to the architecture-independent `start_kernel()` function.
- Initializes high-level kernel subsystems
- Mounts root filesystem
- Starts the `init` process

# 4.3. Android Init

- Open, parses, and runs /init.rc:
  - Create mountpoints and mount filesystems
  - Set up filesystem permissions
  - Set OOM adjustments properties
  - Start daemons:
    - adbd
    - servicemanager (binder context manager)
    - vold
    - netd
    - rild
    - app\_process -Xzygote (Zygote)
    - mediaserver
    - ...

## 4.4. Zygote, etc.

- Init:
  - `app_process -Xzygote (Zygote)`
- `frameworks/base/cmds/app_process/app_main.cpp`:
  - `runtime.start("com.android.internal.os.Zygote", ...`
- `frameworks/base/core/jni/AndroidRuntime.cpp`:
  - `startVM()`
  - Call Zygote's `main()`
- `frameworks/base/core/java/com/android/internal/os/ZygoteInit.java`:
  - ...

- preloadClasses()
  - startSystemServer()
  - ... magic ...
  - Call SystemServer's run()
- frameworks/base/services/java/com/android/server/SystemServer.java:
    - Start **all** system services/managers
    - Start ActivityManager:
      - Send Intent.CATEGORY\_HOME
      - Launcher2 kicks in

# 5. Linux Kernel

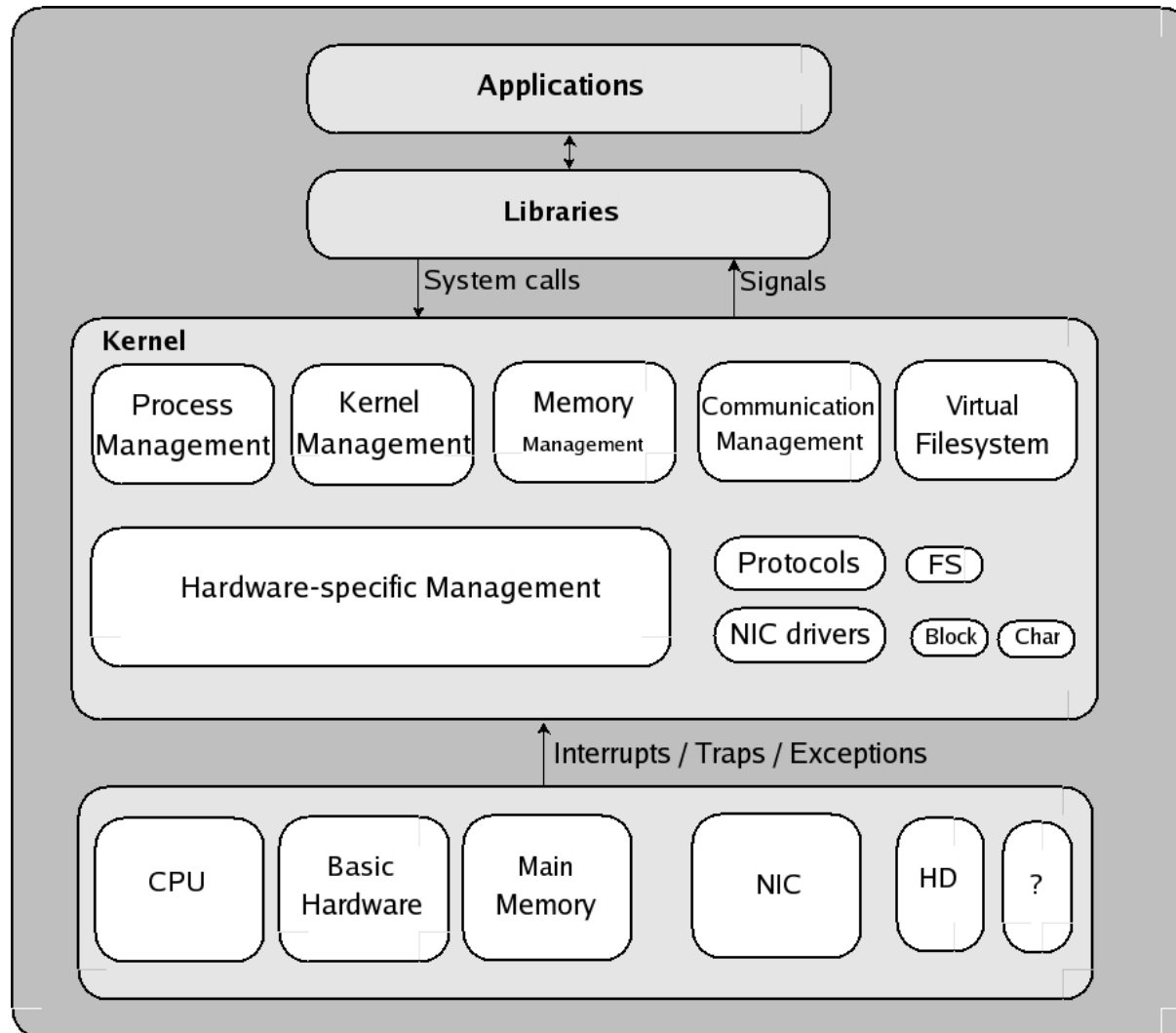

# 5.1. Androidisms

- Wakelocks
- lowmem handler
- Binder
- ashmem – Anonymous Shared Memory
- RAM console
- Logger
- ...

# 6. Hardware support

Bluetooth	BlueZ through D-BUS IPC (to avoid GPL contamination it seems)
GPS	Manufacturer-provided libgps.so
Wifi	wpa_supplicant
Display	Std framebuffer driver (/dev/fb0)
Keymaps and Keyboards	Std input event (/dev/event0)
Lights	Manufacturer-provided liblights.so
Backlight	
Keyboard	
Buttons	
Battery	
Notifications	
Attention	
Audio	Manufacturer-provided libaudio.so (could use ALSA underneath ... at least as illustrated in their porting guide)
Camera	Manufacturer-provided libcamera.so (could use V4L2 kernel driver underneath ... as illustrated in porting guide)
Power Management	"Wakelocks" kernel patch
Sensors	Manufacturer-provided libsensors.so
Accelerometer	
Magnetic Field	
Orientation	
Gyroscope	
Light	
Pressure	
Temperature	
Proximity	
Radio Layer Interface	Manufacturer-provided libril-<companyname>-<RIL version>.so

# 7. Native User-Space

- Mainly
  - /data => User data
  - /system => System components
- Also found:
  - /dev
  - /proc
  - /sys
  - /sbin
  - /mnt
  - /cache
  - Etc.

- Libs:
  - Bionic, SQLite, SSL, OpenGL|ES,
  - Non-Posix: limited Pthreads support, no SysV IPC
- Toolbox
- Daemons:
  - servicemanager, vold, rild, netd, adbd, ...

# 8. Dalvik

- Sun-Java =  
Java language + JVM + JDK libs
- Android Java =  
Java language + Dalvik + Apache Harmony
- Target:
  - Slow CPU
  - Relatively low RAM
  - OS without swap space
  - Battery powered
- Now has JIT

# 8.1. Dalvik's .dex files

- JVM munches on “.class” files
- Dalvik munches on “.dex” files
- .dex file = .class files post-processed by “dx” utility
- Uncompressed .dex = 0.5 \* Uncompressed .jar

# 9. JNI – Java Native Interface

- Call gate for other languages, such as C, C++
- Equivalent to .NET's pinvoke
- Usage: include and call native code from App
- Tools = NDK ... samples included
- Check out “*JNI Programmer's Guide and Specification*” - freely available PDF

# 10. System Services

Entropy Service  
Power Manager  
Activity Manager  
Telephone Registry  
Package Manager  
Account Manager  
Content Manager  
System Content Providers  
Battery Service  
Lights Service  
Vibrator Service  
Alarm Manager  
Init Watchdog  
Sensor Service  
Window Manager  
Bluetooth Service

Device Policy  
Status Bar  
Clipboard Service  
Input Method Service  
NetStat Service  
NetworkManagement Service  
Connectivity Service  
Throttle Service  
Accessibility Manager  
Mount Service  
Notification Manager  
Device Storage Monitor  
Location Manager  
Search Service  
DropBox Service  
Wallpaper Service

Audio Service  
Headset Observer  
Dock Observer  
UI Mode Manager Service  
Backup Service  
AppWidget Service  
Recognition Service  
*Status Bar Icons*  
DiskStats Service  
ADB Settings Observer

## System Services

### System Server

#### Java-built Services

Power Manager	Mount Service
Activity Manager	Notification Manager
Package Manager	Location Manager
Battery Service	Search Service
Window Manager	Wallpaper Service
Status Bar	Headset Observer
Clipboard Service	...

#### C-built Services

Sensor Service

#### Surface Flinger

#### Media Service

Audio Flinger  
Media Player Service  
Camera Service  
Audio Policy Service

##### Includes:

- StageFright
- Audio effects
- DRM framework

#### Phone App

JNI

Native Methods for  
Java-built Services

Hardware Abstraction Layer

# 11. Calling on System Services

- Use `getSystemService`
- Ex: NotificationManager Object reference:

```
String ns = Context.NOTIFICATION_SERVICE;
```

```
NotificationManager mNotificationManager = (NotificationManager) \  
getSystemService(ns);
```

- Prepare your content
- Call on the object:

```
mNotificationManager.notify(HELLO_ID, notification);
```

# 12. ActivityManager

- Start new Activities, Services
- Fetch Content Providers
- Intent broadcasting
- OOM adj. maintenance
- Application Not Responding
- Permissions
- Task management
- Lifecycle management

- Ex. starting new app from Launcher:
  - onClick(Launcher)
  - startActivity(Activity.java)
  - *<Binder>*
  - ActivityManagerService
  - startViaZygote(Process.java)
  - *<Socket>*
  - Zygote

# 13. Binder

- CORBA/COM-like IPC
- Data sent through “parcels” in “transactions”
- Kernel-supported mechanism
- /dev/binder
- Check /proc/binder/\*
- android.\* API connected to System Server through binder.

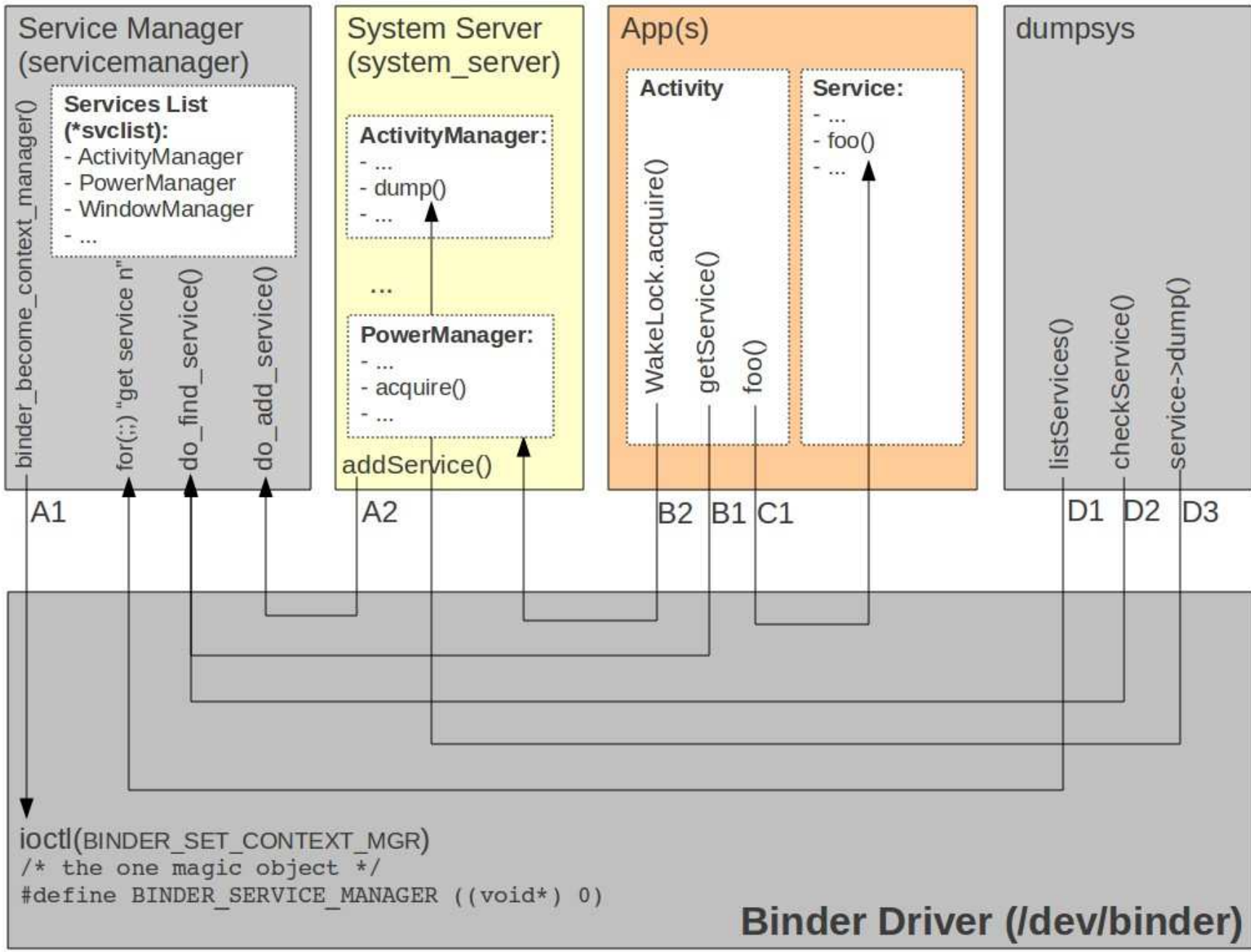

# 14. Hardware Abstraction Layer

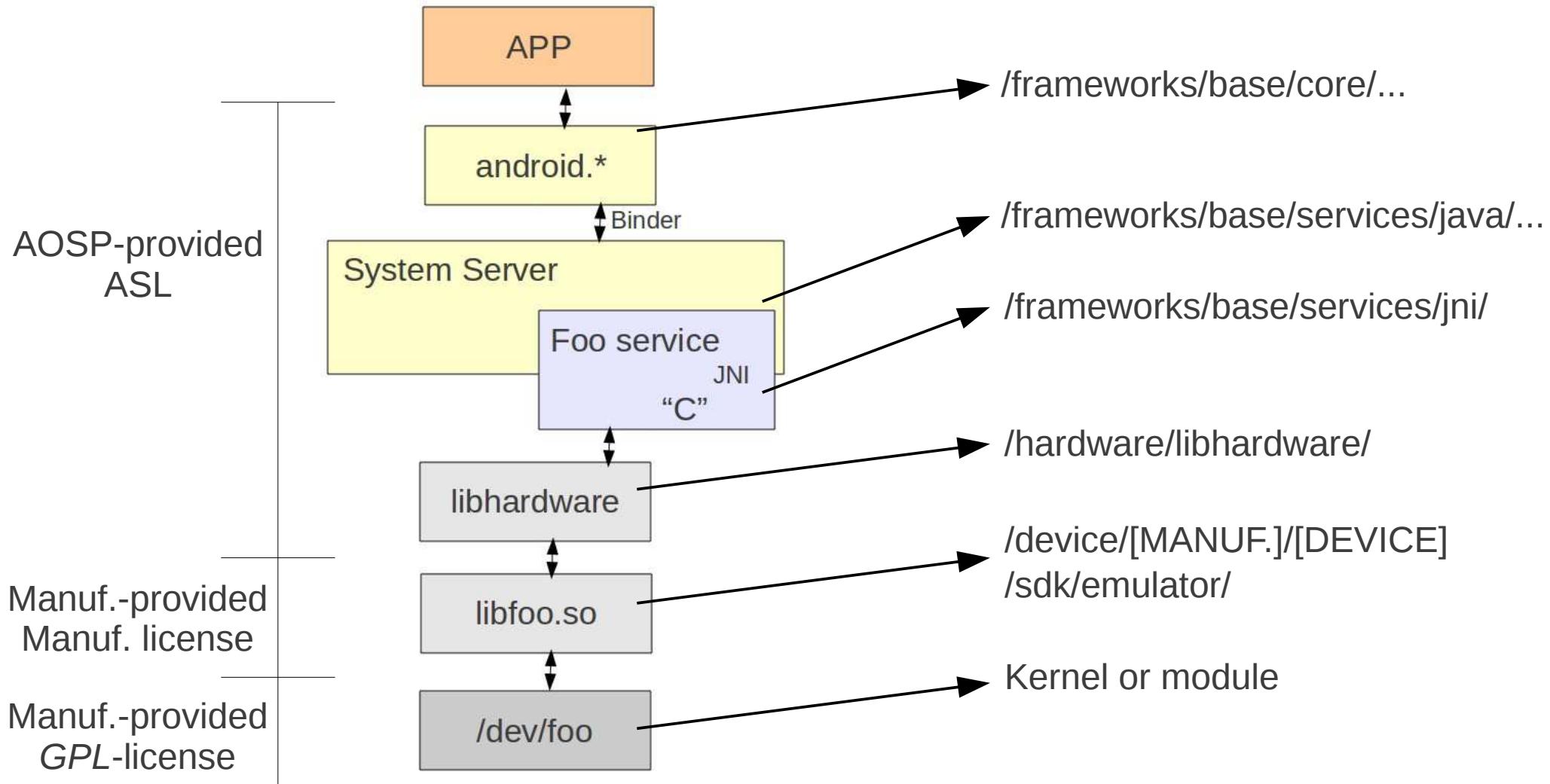

# 15. Stock AOSP Apps

## /packages/apps

AccountsAndSettings  
AlarmClock  
Bluetooth  
Browser  
Calculator  
Calendar  
Camera  
CertInstaller  
Contacts  
DeskClock  
Email  
Gallery  
HTMLViewer

Launcher2  
Mms  
Music  
PackageInstaller  
Protips  
Provision  
QuickSearchBox  
Settings  
SoundRecorder  
SpeechRecorder  
Stk  
VoiceDialer

## /packages/providers

ApplicationProvider  
CalendarProvider  
ContactsProvider  
DownloadProvider  
DrmProvider  
GoogleContactsProvider  
MediaProvider  
TelephonyProvider  
UserDictionaryProvider

## /packages/inputmethods

LatinIME  
OpenWnn  
PinyinIME

# Working with the Android Open Source Project

- Tools and location
- Content
- Building
- Build tricks
- Build system architecture
- Output images
- Using adb
- Custom toolchains and dev kits
- Compatibility Test Suite
- Basic hacks

# 1. Tools and location

- Location:
  - <http://android.googlesource.com/>
- Get “repo”:

```
$ curl https://dl-ssl.google.com/dl/googlesource/git-repo/repo > ~/bin/repo
```

```
$ chmod a+x ~/bin/repo
```
- Fetch the AOSP:
  - Make sure you fetch a tagged release
  - Jelly Bean:

```
$ repo init -u https://android.googlesource.com/platform/manifest
```

```
-b android-4.2.2_r1
```

```
$ repo sync
```

# 2. Content

bionic	C library replacement
bootable	Reference bootloader
build	Build system
cts	Compatibility Test Suite
dalvik	Dalvik VM
development	Development tools
device	Device-specific files and components
external	Copy of external projects used by AOSP
frameworks	System services, android.*, Android-related cmds, etc.
hardware	Hardware support libs
libcore	Apache Harmony
ndk	The NDK
packages	Stock Android apps, providers, etc.
prebuilt	Prebuilt binaries
sdk	The SDK
system	pieces of the world that are the core of the embedded linux platform at the heart of Android.

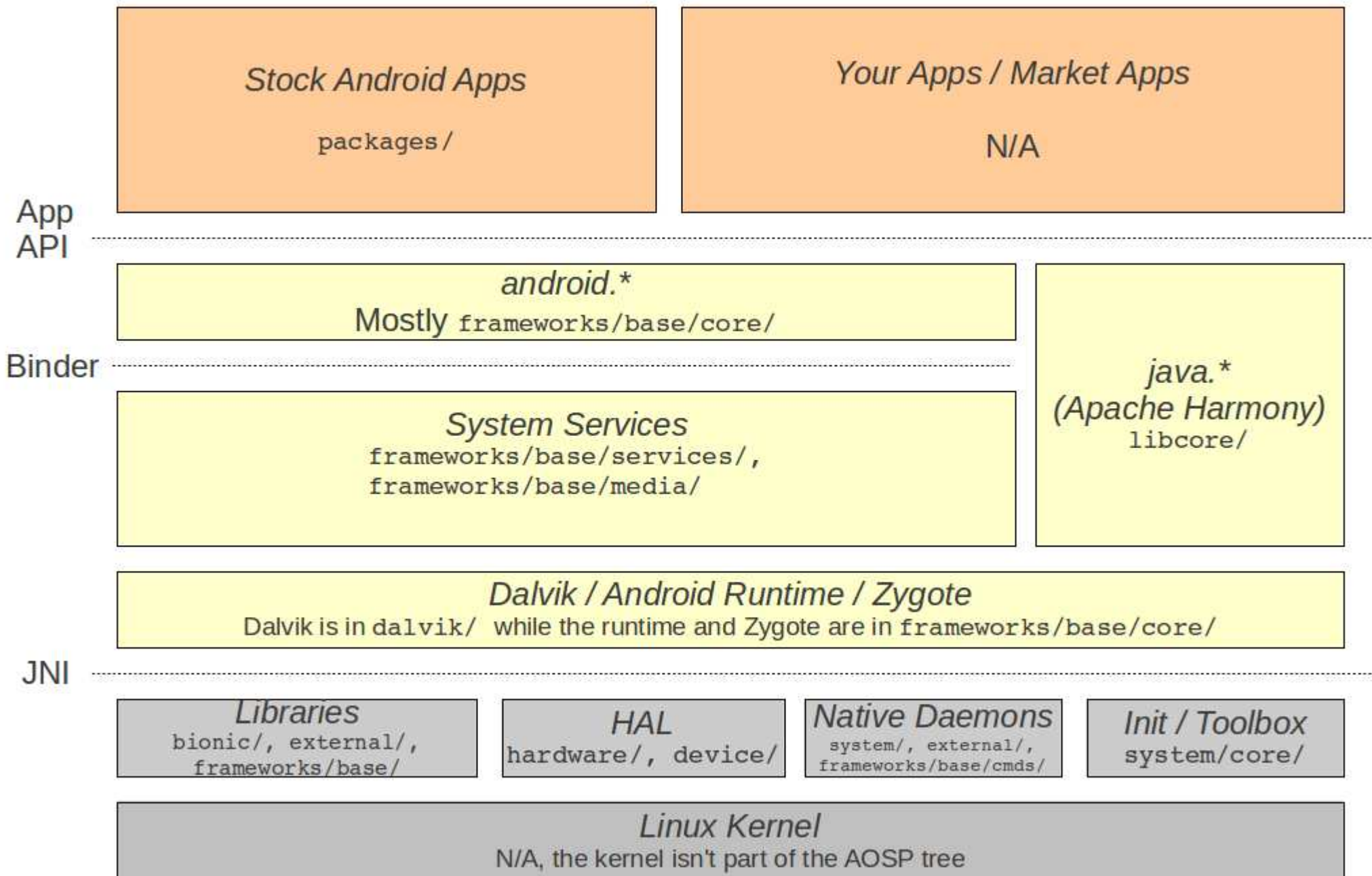

# 3. Building

- Requires 64-bit Ubuntu 10.04

- Packages required:

```
$ sudo apt-get install build-essential libc6-dev \
> ia32-libs lib32z1 bison flex gperf git-core \
> g++ libc6-dev-i386 libz-dev libx11-dev \
> libstdc++6 lib32ncurses5 lib32ncurses5-dev \
> g++-multilib
```

- Possibly fix a few symbolic links:

```
$ sudo ln -s /usr/lib32/libstdc++.so.6 /usr/lib32/libstdc++.so
```

```
$ sudo ln -s /usr/lib32/libz.so.1 /usr/lib32/libz.so
```

- Set up build environment:

```
$ ./build/envsetup.sh
```

```
$ lunch
```

- Launch build and go watch tonight's hockey game:

```
$ make -j2
```

- ... though you should check your screen at breaks ...

- Just launch emulator when it's done:

```
$ emulator &
```

- Need to reuse envsetup.sh and lunch on every new shell

# 4. Build Tricks

- Commands (from build/envsetup.sh):
  - godir
  - croot
  - mm
  - m
- Speeding up the Build:
  - CPU
  - RAM
  - SSD
  - CCACHE
    - `$ export USE_CCACHE=1`

# 5. Build System Architecture

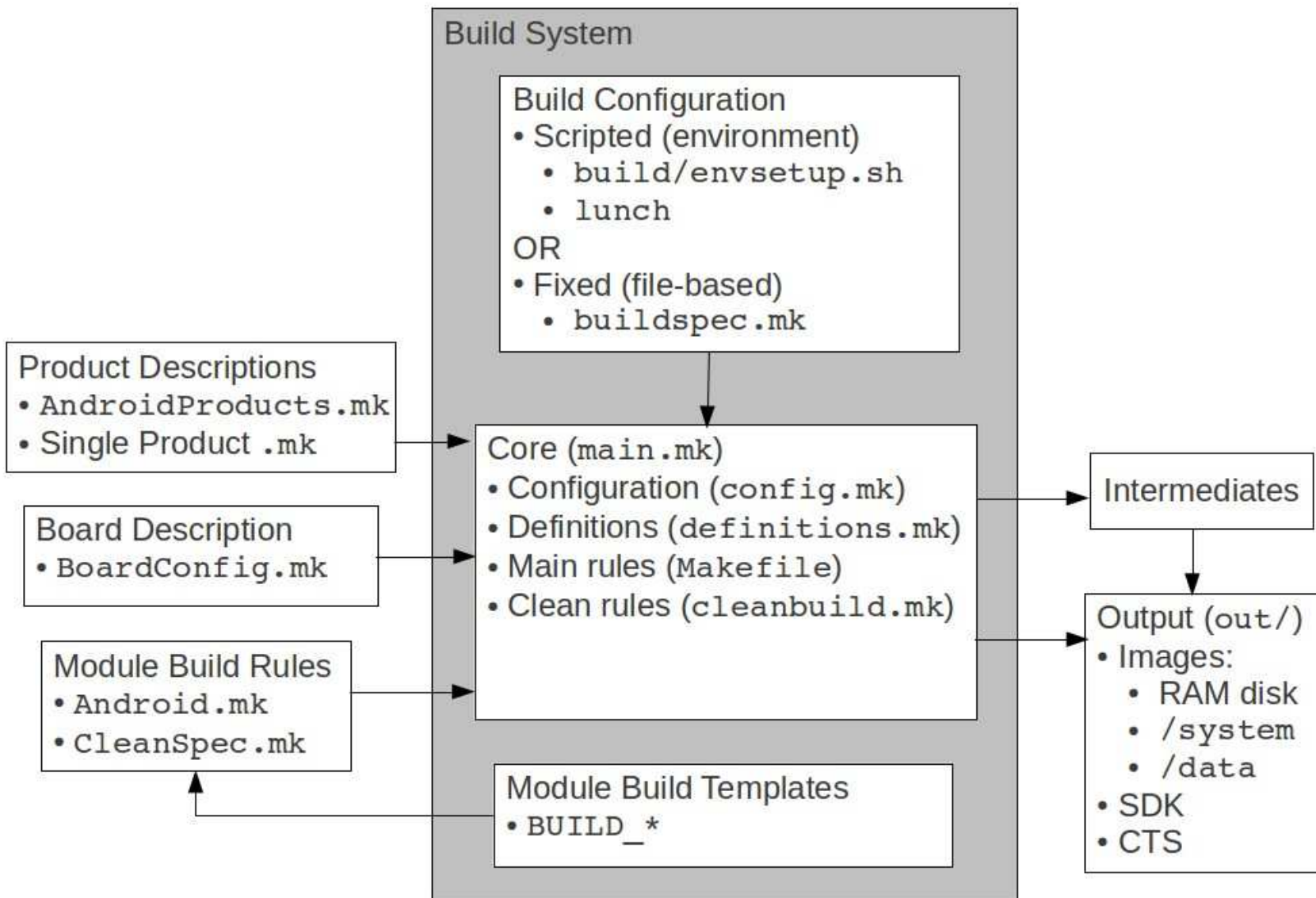

# 6. Output Images

- All output and build in [aosp]/out/
- Images at [aosp]/out/target/product/generic/:
  - ramdisk.img
  - system.img
  - userdata-qemu.img
- Kernel is in:
  - prebuilt/android-arm/kernel/kernel-qemu
- Emulator overrides:
  - -kernel
  - -initrd

# 7. Using adb

- Can use to control/interface w/ running AOSP, including emulator.

- Shell:

```
$ adb shell
```

```
#
```

Host

Target

- Dumping the log:

```
$ adb logcat
```

- Copying files to/from target:

```
$ adb push foo /data/local
```

```
$ adb pull /proc/config.gz
```

# 8. Custom Toolchains and Dev Kits

- Rationale
- SDK generation
- NDK generation

# 8.1. Rationale

- SDK:
  - Providing other internal teams or external developers access to your modified/custom Android APIs.
- NDK:
  - Same as SDK rationale
- Custom cross-dev toolchain:
  - To avoid having to use a binary toolchain from 3<sup>rd</sup> party.
  - To control the build parameters used to create the toolchain. Ex.: use uClibc instead of glibc.

## 8.2. SDK generation

- Building the SDK:

```
$ . build/envsetup.sh
```

```
$ lunch sdk-eng
```

```
$ make sdk
```

- If API modified, do this before make:

```
$ make update-api
```

- Location: [aosp]/out/host/linux-x86/sdk/

- Using a custom SDK:

- Eclipse->Window->Preferences->Android->"SDK Location"

- Eclipse->Window->"Android SDK and AVD Manager"->"Installed Packages"->"Update All..."

# 8.3. NDK generation

- Build

```
$ cd ndk/build/tools
```

```
$ export ANDROID_NDK_ROOT=[aosp]/ndk
```

```
$ ./make-release --help
```

```
$ ./make-release
```

IMPORTANT WARNING !!

This script is used to generate an NDK release package from scratch for the following host platforms: linux-x86

This process is **EXTREMELY LONG** and may take **SEVERAL HOURS** on a dual-core machine. If you plan to do that often, please read docs/DEVELOPMENT.TXT that provides instructions on how to do that more easily.

Are you sure you want to do that [y/N]

# 9. Compatibility Test Suite

- Android Compatibility Program:
  - Source code to Android stack
  - Compatibility Definition Document (CDD) – Policy
  - Compatibility Test Suite (CTS) – Mechanism
- Each Android version has own CDD & CTS
- CTS:
  - Part of AOSP
  - Run from host using USB over to attached device
  - Based on JUnit
  - Runs various test apps on target
  - Relies on ADB
  - Provides report to be analyzed and/or sent back to Google



On your machine

Download and install the CTS.

Run the CTS.

Store and view results.

Devices you attach to your machine



Test execution

Test results

- Report:
  - .zip file containing XML files and screen-shots
  - Sent to: [cts@android.com](mailto:cts@android.com)
- Building the CTS:

```
$ . build/envsetup.sh  
$ make cts
```
- Launching the CTS:

```
$ cd out/host/linux-x86/bin/  
$ ./cts  
$ cts_host >  
$ cts_host > help  
...
```

- Using the CTS:

```
$ cts_host > ls --plan
```

List of plans (8 in total):

Signature

RefApp

VM

Performance

AppSecurity

Android

Java

CTS

```
$ ./cts start --plan CTS
```

- Areas covered:
  - Signature tests
  - Platform API tests
  - Dalvik VM tests
  - Platform Data Model
  - Platform Intents
  - Platform Permissions
  - Platform Resources

# 10. Basic Hacks

- Add device
- Add app
- Add app overlay
- Add native tool or daemon
- Add native library

# 10.1. Adding a new device

- Create directory in device/
  - device/acme/coyotepad/
- Makefile checklist:
  - AndroidProducts.mk
  - full\_coyotepad.mk
  - BoardConfig.mk
  - Android.mk
- Menu integration:
  - vendorsetup.sh

# 10.1.1. AndroidProducts.mk

```
PRODUCT_MAKEFILES := \  
$(LOCAL_DIR)/full_coyotepad.mk
```

## 10.1.2. full\_coyotepad.mk

```
$(call inherit-product, $(
(SRC_TARGET_DIR)/product/languages_full.mk)

# If you're using 4.2/Jelly Bean, use full_base.mk instead of
full.mk

$(call inherit-product, $(SRC_TARGET_DIR)/product/full.mk)

DEVICE_PACKAGE_OVERLAYS :=

PRODUCT_PACKAGES +=

PRODUCT_COPY_FILES +=

PRODUCT_NAME := full_coyotepad

PRODUCT_DEVICE := coyotepad

PRODUCT_MODEL := Full Android on CoyotePad, meep-meep
```

# 10.1.3. BoardConfig.mk

```
TARGET_NO_KERNEL := true  
TARGET_NO_BOOTLOADER := true  
TARGET_CPU_ABI := armeabi  
BOARD_USES_GENERIC_AUDIO := true  
USE_CAMERA_STUB := true
```

## 10.1.4. Android.mk

```
LOCAL_PATH := $(call my-dir)
include $(CLEAR_VARS)
ifneq ($(filter coyotepad,$(TARGET_DEVICE)),)
include $(call all-makefiles-under,$(LOCAL_PATH))
endif
```

# 10.1.5. vendorsetup.sh

```
add_lunch_combo full_coyotepad-eng
```

## 10.1.4. Android.mk

```
LOCAL_PATH := $(call my-dir)
include $(CLEAR_VARS)
ifneq ($(filter coyotepad,$(TARGET_DEVICE)),)
include $(call all-makefiles-under,$(LOCAL_PATH))
endif
```

# 10.2. Adding new applications

- Can use Eclipse to create initial version
- Copy Eclipse project to packages/apps
- Local:
  - Add app to device/acme/coyotepad/
  - Add Android.mk to app
  - Add to PRODUCT\_PACKAGES in full\_coyotepad.mk
- Global:
  - Add application in [aosp]/packages/apps
  - Add an appropriate Android.mk file to project
  - Add project to PRODUCT\_PACKAGES in [aosp]/build/target/product/core.mk

```
LOCAL_PATH:= $(call my-dir)
include $(CLEAR_VARS)
LOCAL_MODULE_TAGS := optional
LOCAL_SRC_FILES := $(call all-java-files-under, src)
LOCAL_PACKAGE_NAME := HelloWorld
include $(BUILD_PACKAGE)
```

# 10.3. Adding an app overlay

- `device/acme/coyotepad/overlay/`
- `full_coyotepad.mk`:
  - `DEVICE_PACKAGE_OVERLAYS := device/acme/coyotepad/overlay`

# 10.4. Adding a native tool or daemon

- Local:
  - device/acme/coyotepad/
- Global:
  - system/core/
  - system/
  - frameworks/base/cmds/
  - frameworks/native/cmds/
  - external/

```
LOCAL_PATH:= $(call my-dir)
include $(CLEAR_VARS)
LOCAL_MODULE := hello-world
LOCAL_MODULE_TAGS := optional
LOCAL_SRC_FILES := hello-world.cpp
LOCAL_SHARED_LIBRARIES := liblog
include $(BUILD_EXECUTABLE)
```

# 10.5. Add a native library

- Local:
  - device/acme/coyotepad/
- Global:
  - system/core/
  - frameworks/base/libs/
  - frameworks/native/libs/
  - external/
- In  $\leq 2.3$ :
  - See build/core/prelink-linux-arm.map

```
LOCAL_PATH:= $(call my-dir)
include $(CLEAR_VARS)
LOCAL_MODULE := libmylib
LOCAL_MODULE_TAGS := optional
LOCAL_PRELINK_MODULE := false
LOCAL_SRC_FILES := $(call all-c-files-under,.)
include $(BUILD_SHARED_LIBRARY)
```

# Kernel basics

1. Selecting a kernel
2. Configuring the kernel
3. Compiling the kernel
4. Installing the kernel
5. Useful boot parameters
6. Kernel patches

# 1. Selecting a kernel

- Google:
  - <http://android.googlesource.com>
- Vanilla:
  - <http://www.kernel.org>
- ~~Either way ... you're screwed:~~
  - ~~Android kernel is a fork~~
  - ~~No resolution in sight~~
  - ~~**Cannot** use vanilla kernel as is ... androidisms~~
- Kernel 3.3 has most Androidisms ... except:
  - Wakelocks

# 2. Configuring the kernel

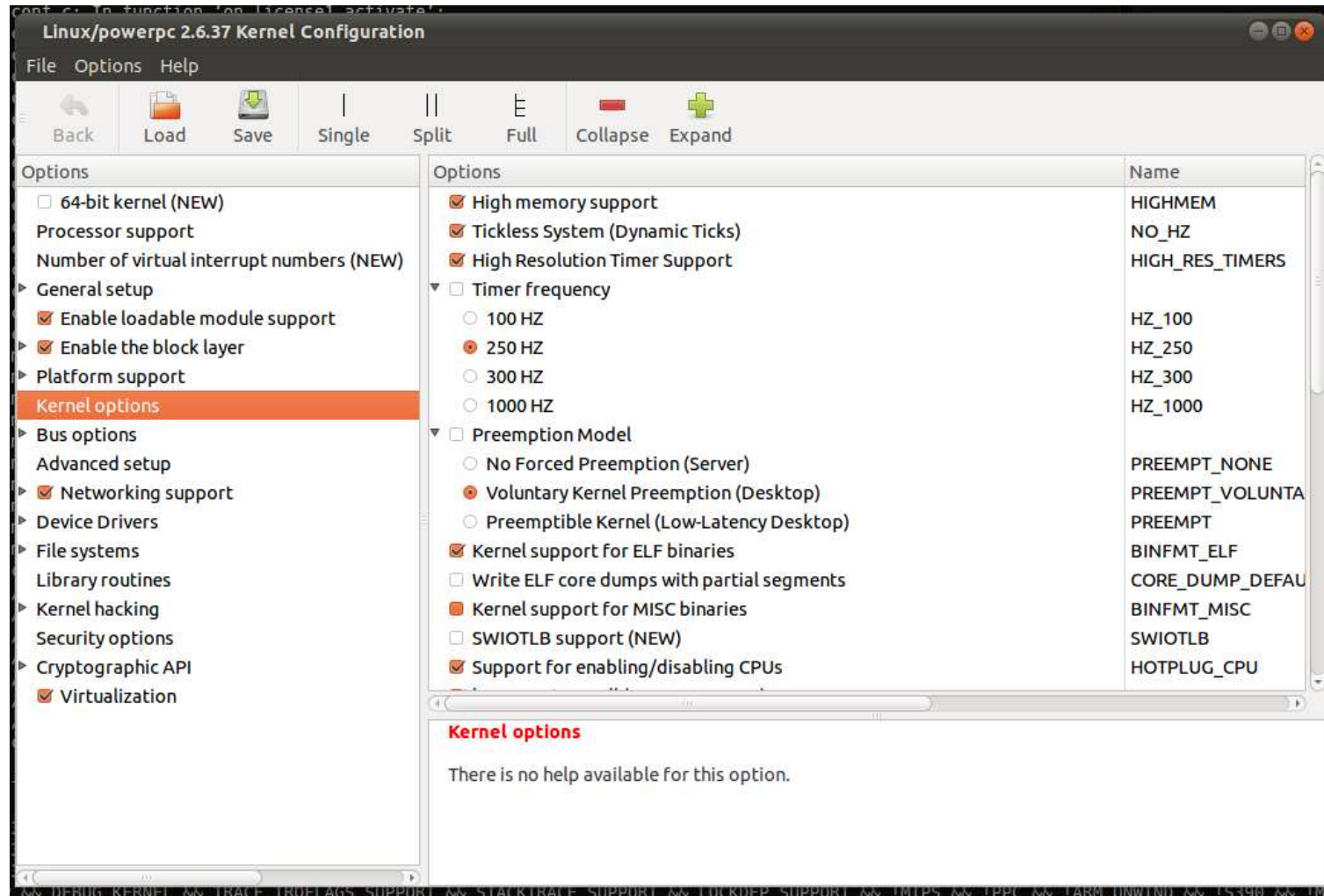

- Main options:
  - Processor support
  - General setup
  - Enable loadable module support
  - Enable the block layer
  - Platform support
  - Kernel options
  - Bus options
  - Advanced setup
  - Networking support
  - Device Drivers
  - File systems
  - Library routines
  - Kernel hacking
  - Security options
  - Cryptographic API

- Kernel architecture name (ARCH=):
  - x86 => x86
  - ARM => arm
  - PPC => powerpc
  - mips => mips
  - sh => sh
- Some options are visible only to certain archs

- The fact that an option is displayed doesn't mean it's supported.
- The fact that an option isn't displayed doesn't mean it isn't supported.
- Configuration methods:
  - `make config`
  - `make oldconfig`
  - `make menuconfig`
  - `make xconfig`
- All config methods generate a `.config` file

- Configs will also generate headers & symlinks
- Set up temporary env. var. for cross-building:

```
$ export TARGET=[your_aosp]/prebuilt/linux-x86/toolchain/arm-eabi-4.4.0/bin/arm-eabi
```
- To start configuration menu for your target:

```
$ make ARCH=arm CROSS_COMPILE=${TARGET}- menuconfig
```
- Some items can be configured as modules and loaded dynamically at runtime.
- Once the configuration is done, quit the menu and save your configuration. This will create a .config file.
- Some targets have preset configurations:

```
$ make ARCH=arm CROSS_COMPILE=${TARGET}- \  
> davinci_all_defconfig
```

- Can use the menus provided by menuconfig and xconfig to load and save various configurations.
- Simplest way to manipulate configurations: copy the .config files by hand.
- To reuse an old configuration, simply copy the .config back to the kernel's tree and:  

```
$ make ARCH=arm CROSS_COMPILE=${TARGET}- oldconfig
```
- Place all your .config files in your \$ {PRJROOT}/kernel directory for easy access.
- Rename your .config files using meaningful names: 2.6.37.config, 2.6.37-frame-buf.config, ...

# 3. Compiling the kernel

## 1. Building the kernel:

- Command:  
`$ make ARCH=arm CROSS_COMPILE=${TARGET}- zImage`
- Generates a kernel image compressed via gzip
- zImage may not be valid target. Other targets include: vmlinux, bzImage, ulmage, culmage, ...
- Use “make ARCH=... help” to find out valid targets
- ARCH variable indicates which architecture subdirectory is to be used.
- CROSS\_COMPILE is used to form the name of the tools. For example, `$(CROSS_COMPILE)gcc` becomes `arm-linux-gcc`. Hence the trailing “-”.

## 2. Building the modules:

```
$ make ARCH=arm CROSS_COMPILE=${TARGET}- modules
```

- **IF YOU NEED TO** restore kernel tree to distribution state:

```
$ make ARCH=arm CROSS_COMPILE=${TARGET}- distclean
```

# 4. Installing the kernel<sup>1</sup>

- Managing multiple kernel images:
  - Images in `#{PRJROOT}/images` must be properly identified.
  - For each kernel, there are 4 files to put in `#{PRJROOT}/images`:
    - The uncompressed image `=> vmlinux`
    - The compressed image `=> depends on arch`
    - The kernel symbols `=> System.map`
    - The kernel configuration file `=> .config`
  - Compressed image is *usually* in the `arch/YOUR_ARCH/boot` directory.

1. This is for **future** reference. `#{PRJROOT}` is undefined at this point

- See the exercise set for target image we are using.
- Location of images can be seen by looking at `arch/YOUR_ARCH/Makefile`
- Images placed in `${PRJROOT}/images` must follow same naming convention as `.config` file:

```
$ cp arch/arm/boot/zImage \  
> ${PRJROOT}/images/zImage-2.6.37  
$ cp System.map ${PRJROOT}/images/System.map-2.6.37  
$ cp vmlinux ${PRJROOT}/images/vmlinux-2.6.37  
$ cp .config ${PRJROOT}/images/2.6.37.config
```

- Installing the kernel modules:
  - Must install modules in directory following the previously adopted naming convention:

```
$ make ARCH=arm CROSS_COMPILE=${TARGET}- \  
> INSTALL_MOD_PATH=${PRJROOT}/images/modules-2.6.37 \  
> modules_install
```
  - `INSTALL_MOD_PATH` is prepended to the default `/lib/modules`. Hence, modules installed in:  
`${PRJROOT}/images/modules-2.6.37/lib/modules`

# Embedded Linux Root FS

1. Legacy Integration
2. Architecture
3. Tools
4. Embedded Linux Workspace
5. Basic root filesystem structure
6. Libraries
7. Kernel modules
8. Device files
9. Main system applications
10. Auto-generating filesystems
11. Creating a cross-development toolchain

# 1. Legacy Integration

- What if I ... ?:
  - have been using my custom rootfs forever
  - really need glibc
  - have a huge stack based on “legacy Linux”
  - don't want to deal with AOSP's build system
  - want BusyBox
  - want to unify with a std Linux desktop
  - need things the AOSP doesn't provide
  - have a ton of Linux drivers and want those to be used by Android
  - ...
- Know this: filesystem integration is trivial:
  - Change build system to copy your custom rootfs
  - Change init scripts to start you own daemons
  - Use sockets to communicate
- Know this too: std Linux desktop integration is NOT

# 2. Architecture

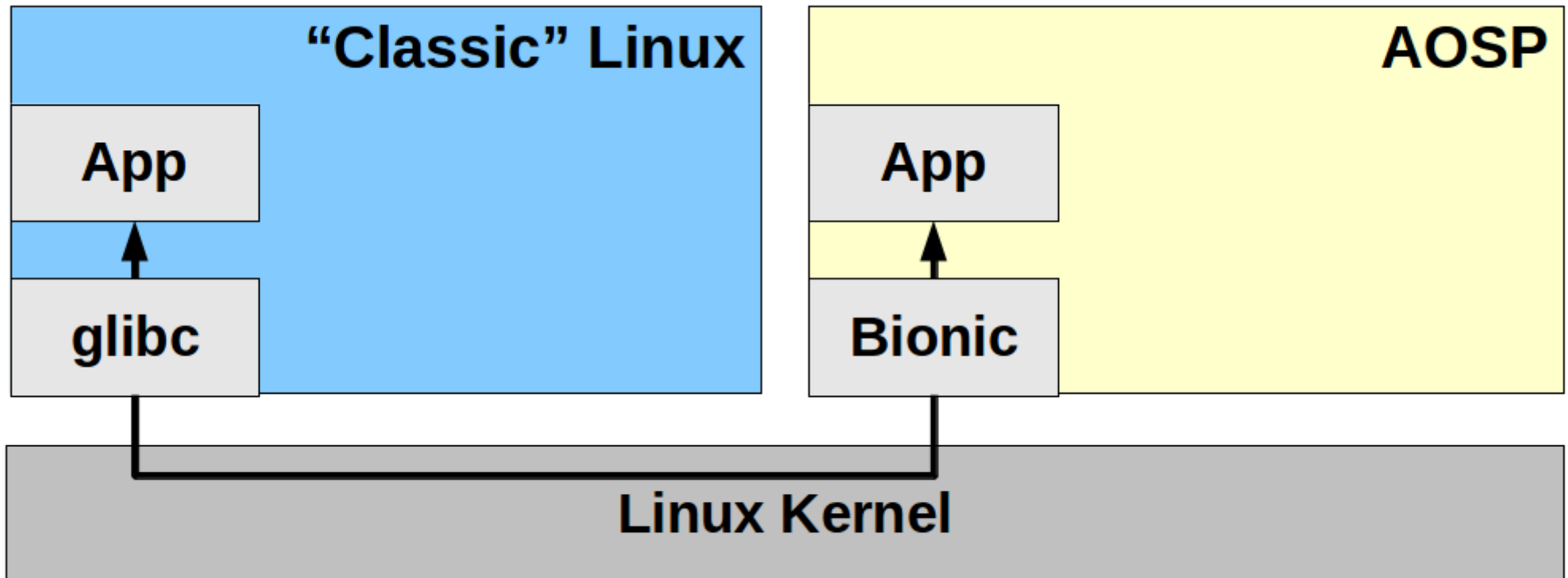

# Host

## AOSP (bionic)

build/  
system/  
frameworks/  
packages/  
external/

## PRJROOT (glibc)

sysapps/  
rootfs/  
build-tools/  
.../

Kernel

# Target

- ramdisk.img => /
  - /bin
  - /lib
- system.img => /system
- userdata.img => /data

Kernel

# 3. Tools

- GNU cross-development toolchain:
  - gcc - compiler
  - as - assembler
  - ld - linker
  - gdb/gdbserver - debugger
  - etc.
- C library: uClibc, eglibc or glibc

# 4. Embedded Linux Workspace

- Need to organize the components used during cross-platform development. Workspace layout:

bootldr:	target bootloader (s)
build-tools:	toolchain build packages and sources
debug:	debugging tools
doc:	project documentation
images:	binary images ready to be used on target
kernel:	sources and build directories for target kernels
project:	your own custom code for the target
rootfs:	root filesystem as seen on the target
sysapps:	sources for target's system applications
tmp:	temporary data and experiments
tools:	toolchain and all other tools required to build software for the target.

# 4.1. Workspace env. vars. script

- Complete workspace script (devex)

```
export PROJECT=emblinux
export PRJROOT=/home/karim/${PROJECT}
export TARGET=arm-unknown-linux-gnueabi
export PATH=${PATH}:[BBONE_WS_DIR]/bin
cd $PRJROOT
```

- To use this script:

```
$ ._devex
```

- Possible values for \$TARGET:

- ARM: arm-linux, arm-unknown-linux-gnueabi
- MIPS: mips-linux, mipsel-unknown-linux-gnu
- I386: i386-linux, i586-geode-linux-uclibc

# 5. Basic root filesystem structure

- Unix FS structured for multi-user systems
- Some directories not necessary for embedded
- Filesystem Hierarchy Standard (FHS):
  - /bin => Essential user binaries
  - /boot => Bootloader and kernel images
  - /dev => Device files
  - /etc => System configuration
  - /home => User home directories
  - /lib => Essential shared libs and kernel modules
  - /mnt => Temporary mount point
  - /opt => Add-on software packages
  - /sbin => Essential system binaries
  - /tmp => Temporary files
  - /usr => Secondary hierarchy (mostly user apps)
  - /var => Variable data generated by daemons

- Non-essential multi-user dirs:
  - /home, /mnt, /opt, /root
- Depends on bootloader:
  - /boot
- ***Traditionally*** “essential”:
  - /bin, /dev, /etc, /lib, /proc, /sbin, /usr, /tmp, /var
- Careful with “/etc”, Android needs it to point to “/system/etc” for Dbus config ... Just hack it.
- Contain their own hierarchy:
  - /usr, /var

- What are all these binaries directories for?
  - /bin => Essential binaries for user and admin
  - /sbin => Essential binaries for admin
  - /usr/bin => Non-essential user and admin binaries
  - /usr/sbin=> Non-essential admin binaries
- What are all those libraries directories for?
  - /lib => Essential system libraries
  - /usr/lib => Non-essential libraries
- The kernel does not force FS layout. Layout is “universally” agree upon (i.e. FHS.)

- To start working on rootfs:  
\$ cd \${PRJROOT}/rootfs
- Create core rootfs directories:  
\$ mkdir bin lib sbin usr var
- Create the /usr hierarchy:  
\$ mkdir usr/{bin,lib,sbin}
- Create the /var hierarchy:  
\$ mkdir var/{lib,lock,log,run,tmp}  
\$ chmod 1777 var/tmp

# 6. Libraries

1.glibc

2.uClibc

# 6.1. glibc

- glibc components:
  - Actual shared libraries:
    - Format: libLIB\_NAME-GLIBC\_VER.so
    - Examples: libm-2.3.2.so, libc-2.3.2.so
  - Major revision version symbolic links:
    - Format: libLIB\_NAME.so.MAJOR\_REV\_VER
    - Examples: libdl.so.2, libc.so.6
  - Version-independent symbolic links to the major revision version symbolic links:
    - Format: libLIB\_NAME.so
    - Examples: libdl.so, libm.so
  - Static library archives:
    - Format: libLIB\_NAME.a
    - Examples: libdl.a, libm.a

- For target, need:
  - The actual shared libs
  - The major revision version symbolic links
- Also need dynamic linker:
  - Actual linker: ld-GLIBC\_VER.so
  - Symbolic link to linker:
    - x86, ARM, SH, m68k => ld-linux.so.MAJOR\_REV\_VER
    - MIPS, PPC => ld.so.MAJOR\_REV\_VER
- Must determine exact library components required.
- BELS table 6.2 contains complete list

- Most important components:
  - `ld` => the dynamic linker
  - `libc` => the C library
  - `libm` => the math library
  - `libdl` => the shared objects manipulation library
- Must determine exact dependencies of your applications.
- Native `ldd` is not cross-platform-capable
- Can use `readelf` or `uclibc-ldd`:

- Using readelf:

```
$ arm-linux-readelf -a ${PRJROOT}/rootfs/bin/busybox \  
> | grep "Shared library"  
0x00000001 (NEEDED)           Shared library: [libc.so.0]
```

- Using uclibc-ldd:

```
$ arm-uclibc-ldd ${PRJROOT}/rootfs/bin/busybox  
libc.so.0 => /home/karim/example-sys/tools/uclibc/lib/libc.so.0  
/lib/ld-uClibc.so.0 => /lib/ld-uClibc.so.0
```

- Copying important libraries to target rootfs:

```
$ cd ${TARGET_PREFIX}/lib  
$ for file in libc libcrypt libdl libm \  
> libpthread libresolv libutil  
> do  
> cp $file-*.so ${PRJROOT}/rootfs/lib  
> cp -d $file.so.[*0-9] ${PRJROOT}/rootfs/lib  
> done  
$ cp -d ld*.so* ${PRJROOT}/rootfs/lib
```

- Copying all libraries:

```
$ cp -d [BBONE_WS_DIR]/tools/arm-unknown-linux-gnueabi/arm-unknown-linux-gnueabi/lib/* ${PRJROOT}/rootfs/lib
```

- Stripping all target libraries for space efficiency:

```
$ arm-unknown-linux-gnueabi-strip ${PRJROOT}/rootfs/lib/*.so*
```

## 6.2. uClibc

- Same naming conventions as glibc
- Implements most of the glibc components:
  - ld, libc, libcrypt, libdl, libm, libpthread, libresolv, libutil.
- uClibc libraries can coexist with glibc libraries in target's /lib directory.
- Copying important libraries to target rootfs:

```
$ cd ${PREFIX}/uclibc/lib
$ for file in libuClibc ld-uClibc libc libdl \
> libcrypt libm libresolv libutil
> do
> cp $file-*.so ${PRJROOT}/rootfs/lib
> cp -d $file.so.[*0-9] ${PRJROOT}/rootfs/lib
> done
```

- Copying all uClibc components:

```
$ cd ${PREFIX}/uClibc/lib  
$ cp *-*.so ${PRJROOT}/rootfs/lib  
$ cp -d *.so.[*0-9] ${PRJROOT}/rootfs/lib
```

- No need to strip uClibc libraries, they are stripped by the uClibc build script.

# 7. Kernel modules

- Kernel modules are located in `/lib/modules`, so they must be installed in `/${PRJROOT}/rootfs/lib/modules`.
- Copying modules built earlier:

```
$ cp -a ${PRJROOT}/images/modules-2.6.37/* \  
> ${PRJROOT}/rootfs
```
- Module loading customization (`/etc/modprobe.conf` or `/etc/modprobe.d/`)

# 8. Device files

- All devices in Linux are seen as files (except Ethernet interfaces.)
- Typical workstation distros use udev
- Keep a copy of Documentation/devices.txt handy
- See BELS table 6.3 for core set of /dev entries
- Properties of each /dev node:
  - Filename (node name)
  - Type (char / block)
  - Major number (What type of device?)
  - Minor number (Which instance of the device?)
  - Permission bits
- No need to create these entries since AOSP does it for us

# 9. Main system applications

- Unix systems rely on a common set of commands
- Standard distros have one binary per command
- May compile each relevant command one-by-one or use packages that provide many commands in a single binary:
  1. Busybox
  2. Distro

# 9.1. BusyBox

- Main package used in embedded Linux to provide core set of Unix commands: [busybox.net](http://busybox.net)

[, [[, acpid, add-shell, addgroup, adduser, adjtimex, arp, arping, ash, awk, base64, basename, beep, blkid, blockdev, bootchartd, brctl, bunzip2, bzip2, cal, cat, catv, chat, chatr, chgrp, chmod, chown, chpasswd, chpst, chroot, chrt, chvt, cksum, clear, cmp, comm, cp, cpio, crond, crontab, cryptpw, cttyhack, cut, date, dc, dd, dealloct, delgroup, deluser, depmod, devmem, df, dhcprelay, diff, dirname, dmesg, dnsd, dnsdomainname, dos2unix, du, dumpkmap, dumpleases, echo, ed, egrep, eject, env, envdir, envuidgid, ether-wake, expand, expr, fakeidentd, false, fbset, fbsplash, fdflush, fdformat, fdisk, fgconsole, fgrep, find, findfs, flock, fold, free, freeramdisk, fsck, fsck.minix, fsync, ftpd, ftpget, ftpput, fuser, getopt, getty, grep, gunzip, gzip, halt, hd, hdparm, head, hexdump, hostid, hostname, httpd, hush, hwclock, id, ifconfig, ifdown, ifenslave, ifplugd, ifup, inetd, init, insmod, install, ionice, iostat, ip, ipaddr, ipcalc, ipcrm, ipcs, iplink, iproute, iprule, iptunnel, kbd\_mode, kill, killall, killall5, klogd, last, length, less, linux32, linux64, linuxrc, ln, loadfont, loadkmap, logger, login, logname, logread, losetup, lpd, lpq, lpr, ls, lsattr, lsmod, lspci, lsusb, lzcat, lzma, lzop, lzopcat, makedevs, makemime, man, md5sum, mdev, mesg, microcom, mkdir, mkdosfs, mke2fs, mkfifo, mkfs.ext2, mkfs.minix, mkfs.vfat, mknod, mkpasswd, mkswap, mktemp, modinfo, modprobe, more, mount, mountpoint, mpstat, mt, mv, nameif, nbd-client, nc, netstat, nice, nmeter, nohup, nslookup, ntpd, od, openvt, passwd, patch, pgrep, pidof, ping, ping6, pipe\_progress, pivot\_root, pkill, pmap, popmaildir, poweroff, powertop, printenv, printf, ps, pscan, pwd, raidautorun, rdate, rdev, readahead, readlink, readprofile, realpath, reboot, reformime, remove-shell, renice, reset, resize, rev, rm, rmdir, rmmmod, route, rpm, rpm2cpio, rtcwake, run-parts, runlevel, runsv, runsvdir, rx, script, scriptreplay, sed, sendmail, seq, setarch, setconsole, setfont, setkeycodes, setlogcons, setsid, setuidgid, sh, sha1sum, sha256sum, sha512sum, showkey, slattach, sleep, smemcap, softlimit, sort, split, start-stop-daemon, stat, strings, stty, su, sulogin, sum, sv, svlogd, swapoff, swapon, switch\_root, sync, sysctl, syslogd, tac, tail, tar, tcpsvd, tee, telnet, telnetd, test, tftp, tftpd, time, timeout, top, touch, tr, traceroute, traceroute6, true, tty, ttysize, tunctl, udhcpc, udhcpd, udpsvd, umount, uname, unexpand, uniq, unix2dos, unlzma, unlzop, unxz, unzip, uptime, usleep, uudecode, uuencode, vconfig, vi, vlock, volname, wall, watch, watchdog, wc, wget, which, who, whoami, xargs, xz, xzcat, yes, zcat, zcip

- Download BusyBox (1.18.3) to your `$ {PRJROOT}/sysapps` directory and extract it there.
- Move to the directory for the rest of the setup:  

```
$ cd ${PRJROOT}/sysapps/busybox-1.18.3
```
- Configuration of BusyBox's options:  

```
$ make menuconfig
```



- “Busybox Settings”:

- “Build Options” -> Cross-compiler prefix:

```
 ${TARGET} -
```

- “Installation Options” -> Installation prefix:

```
 ${PRJROOT} /rootfs
```

- Build:

```
 $ make
```

- Install:

```
 $ make install
```

- Only one binary has been installed: /bin/busybox
- All commands are symbolic links to /bin/busybox
- Determining the command issued done through main's argv[ ] and argc.
- Creating arbitrary links doesn't work
- BusyBox can be told to create hard-links
- Full command doc on web and in package
- Customizing the paths for the various shells:

```
# Set path
PATH=/bin:/sbin:/usr/bin:/usr/sbin
export PATH
```

# 10. Auto-generating FSes/distros

- Yocto
- Buildroot
- PTXdist
- OpenWRT
- LTIB
- OpenEmbedded
- Gentoo

# 11. Creating a cross-dev toolchain

- **crosstool-ng**: successor to crosstool
- Available at:
  - <http://ymorin.is-a-geek.org/projects/crosstool>
- Downloads, patches, builds, installs, etc.
- Comprises **23** steps
- Menuconfig-based
- Supports uClibc, glibc and eglibc
- Supports ARM, Blackfin, MIPS, PowerPC, SH, ...
- Fairly well maintained

- Must make sure the following are installed on Ubuntu in order to use crosstool-ng:
  - gawk
  - texinfo
  - automake
  - libtool
  - cvs
  - libncurses5-dev
- Use “sudo apt-get install” to get those

- Download and extract to `${PRJROOT}/build-tools`
- Configure crosstool:

```
$ cd crosstool-ng-1.10.0/
$ ./configure
```
- Build and install crosstool-ng:

```
$ make
$ make install
```
- Configure crosstool:

```
$ cd ${PRJROOT}/build-tools
$ ct-ng menuconfig
```

- Options:
  - Paths->Prefix directory: `${PREFIX}/${CT_TARGET}`
  - Target options->architecture: arm
  - OS->Target OS: linux
  - C library->C library: glibc
  - C library->Extra flags: `-U_FORTIFY_SOURCE`
  - Debug facilities: gdb & strace
- Build the toolchain:

```
$ ct-ng build
```

# Native Android User-Space

1. Filesystem layout
2. Architecture vs. filesystem
3. Build system and filesystem
4. adb
5. Command line
6. Init
7. ueventd
8. Boot logo
9. Bionic
10. Tiny Android

# 1. Filesystem layout

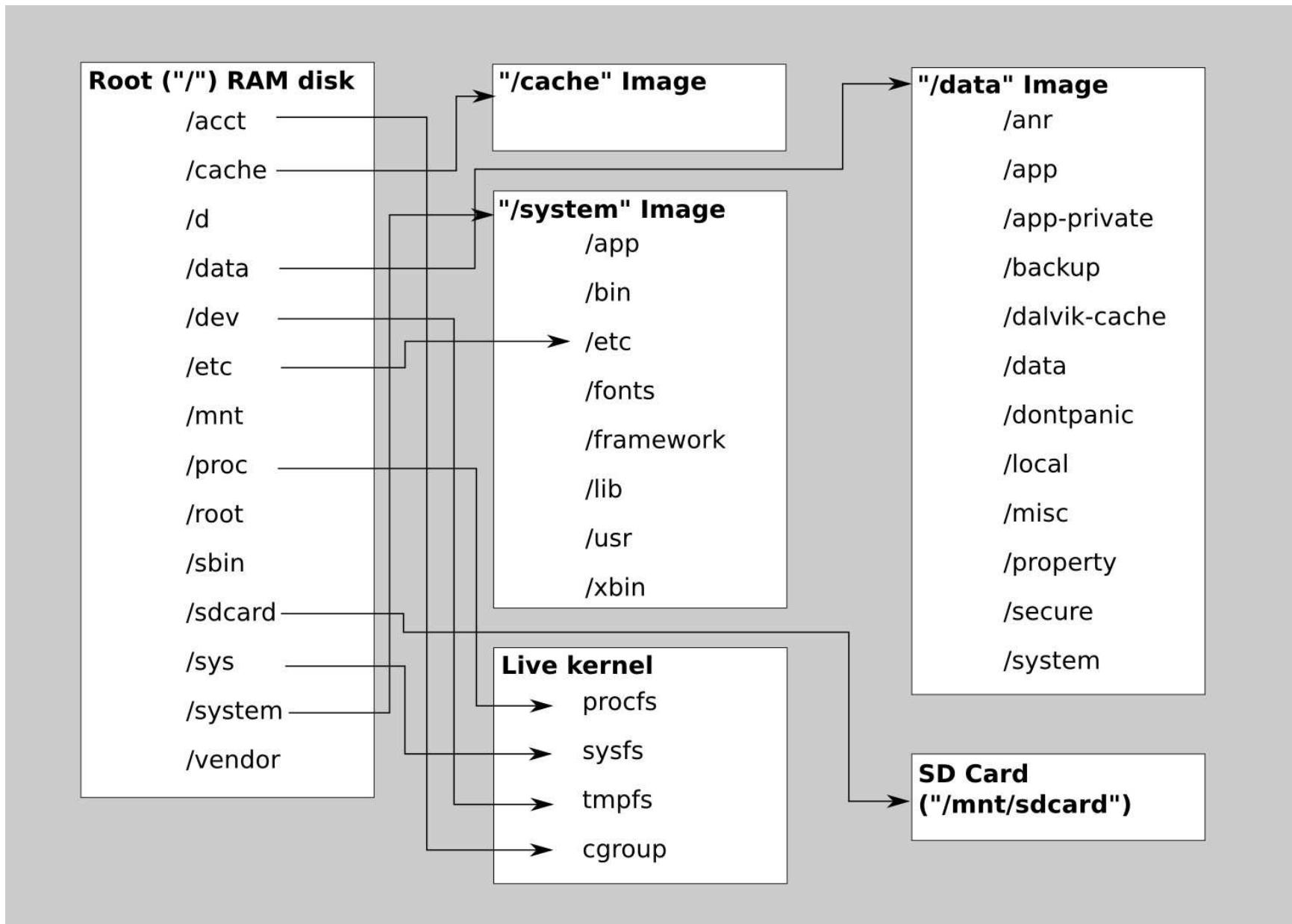

# 1.1. Root directory

- /acct => Control Group mount point (Documentation/cgroups.txt)
- /cache => cache flash partition
- /d => Symlink to /sys/kernel/debug
- /data => Android's "/data" filesystem
- /dev => Device nodes
- /etc => Symlink to /system/etc
- /mnt => Temporary mount point
- /proc => procfs
- /root => unused
- /sbin => eventd and adbd
- /sdcard => SD card mountpoint
- /sys => sysfs
- /system => Android's "/system" filesystem
- /vendor => Symlink to /system/vendor

# 1.1. /system

- /app => Stock apps installed
- /bin => Native binaries and daemons
- /etc => Configuration files
- /fonts => TTFs
- /framework => Android framework .jar files
- /lib => Native libraries
- /usr => Miniature “/usr”
- /xbin => Optional/Extra binaries

# 1.2. /data

- /anr => ANR traces
- /app => App install location
- /app-private => Protected apps
- /backup => For Backup Manager
- /dalvik-cache => Dalvik DEX cache
- /data => App data
- /dontpanic => Last panic output (console + threads) for “dumpstate”
- /local => Shell-writable space
- /misc => Misc. data (wifi, vpn, bluetooth, ...)
- /property => Persistent system properties (country, lang., ...)
- /secure => Secure Android data available
- /system => System data

# 2. Architecture vs. filesystem

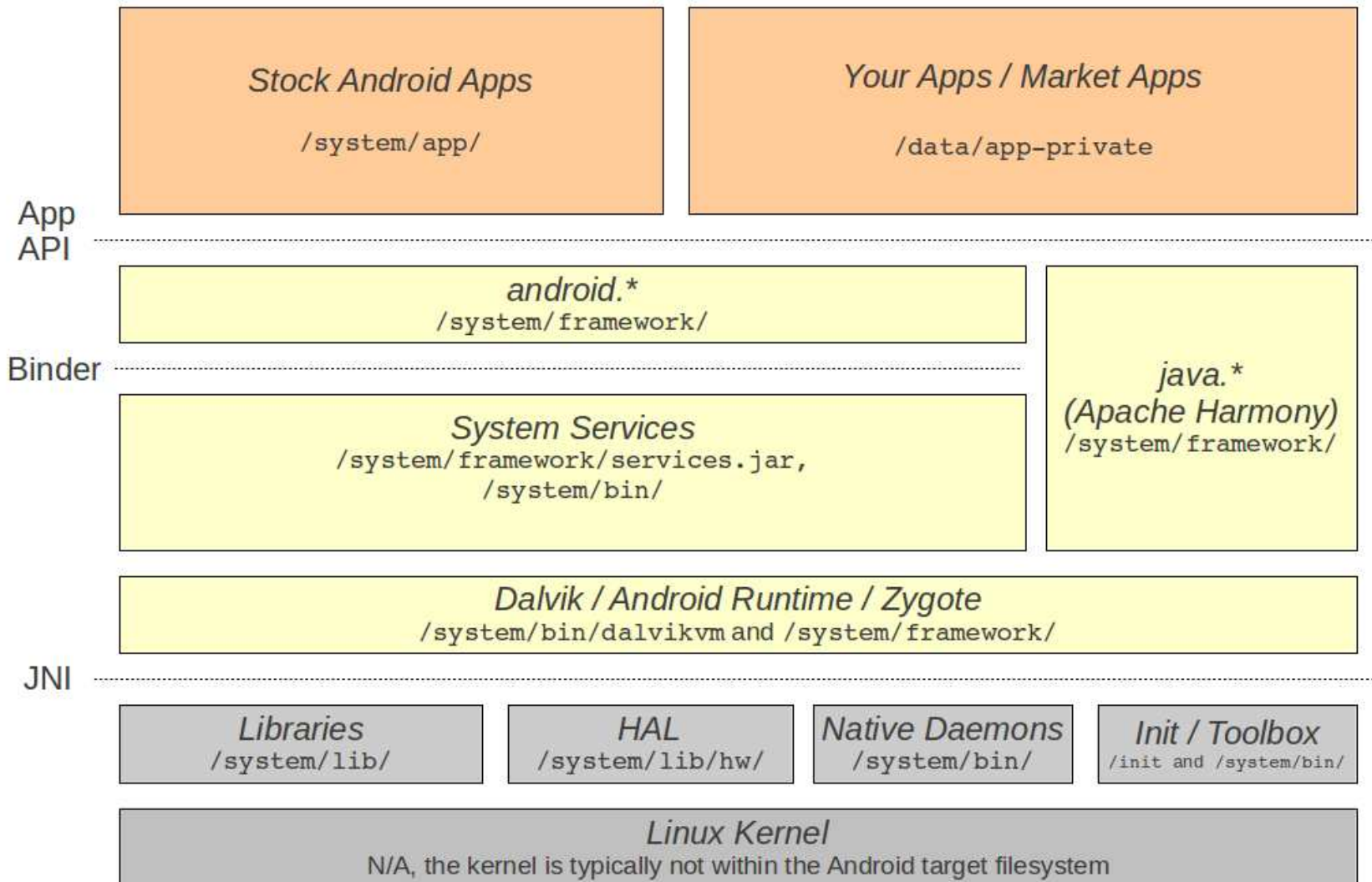

# 3. Build system and filesystem

- Build templates
  - `BUILD_EXECUTABLE = /system/bin`
  - `BUILD_SHARED_LIBRARY = /system/lib`
  - `BUILD_PACKAGE = /system/app`
- Default rights and ownership
  - `system/core/include/private/android_filesystem_config.h`
  - User IDs / names
  - `android_dirs` struct
  - `android_files` struct

# 4. adb

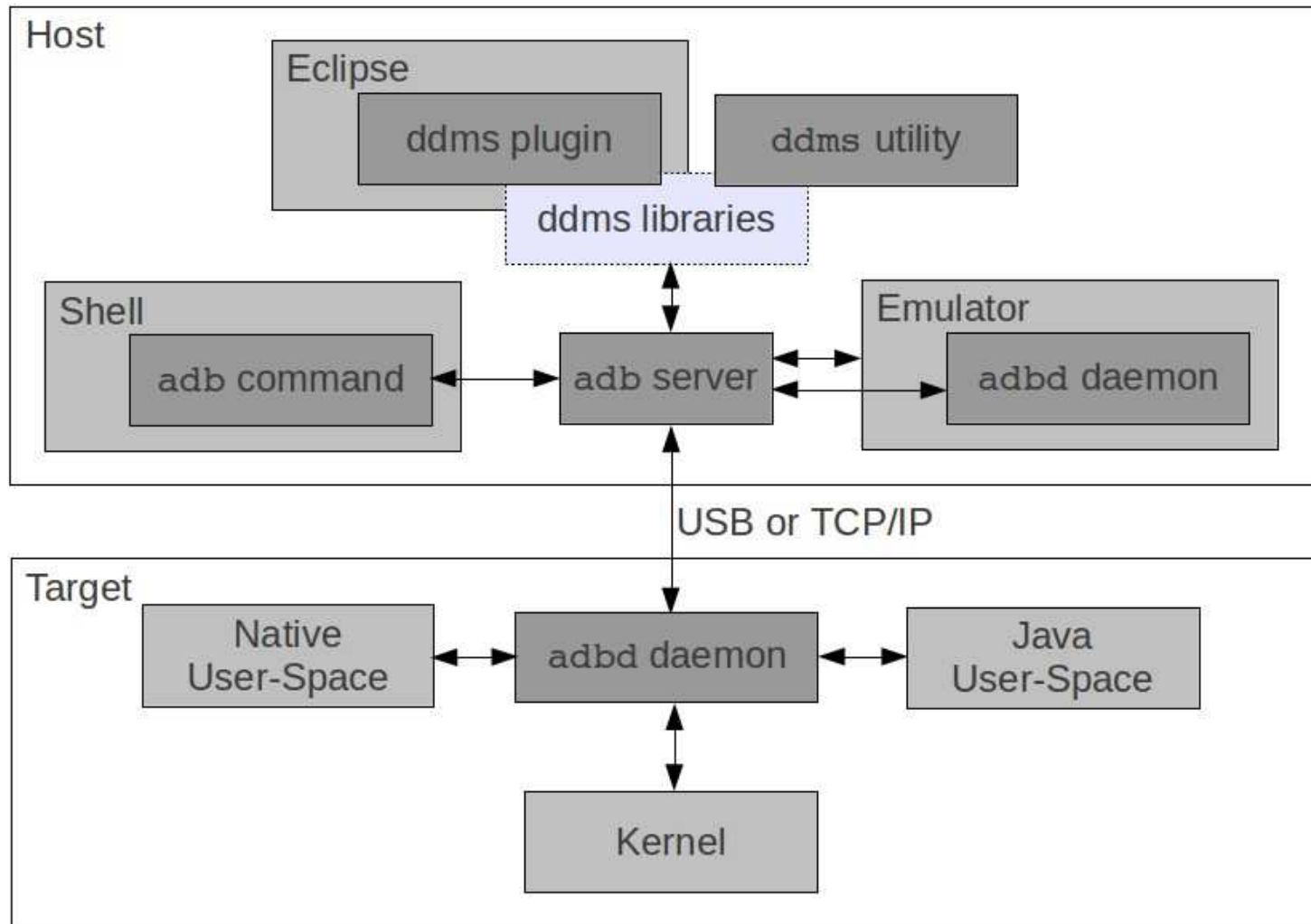

# 4.1. What adb can do

- See online help for full details
- Managing device connections
- Remote commands:
  - shell
  - log dumping
  - bug reports
  - port forwarding
  - dalvik debugging

- Filesystem commands
  - push
  - pull
  - sync
  - install / uninstall
- State-altering commands
  - reboot
  - run as root
  - switching connection type
  - controlling the emulator
- Tunneling PPP

# 5. Command line

- Shell:
  - NetBSD shell up to 2.3/GB
  - MirBSD Korn shell since 4.0/ICS
- Toolbox:
  - Traditional Linux commands
  - Global properties
  - Input events
  - Services control
  - Logging
  - ioctl
  - Device wiping
  - etc.

- In aosp:
  - /system/core/toolbox
- In filesystem:
  - /system/bin/toolbox
- Provides

alarm date getevent insmod ls mv powerd renice schedtop  
 smd top dd getprop ioctl lsmmod nandread printenv rm  
 sendevent start umount cat hd ionice lsof netstat ps rmdir  
 setconsole stop uptime chmod df id kill mkdir newfs\_msdos r  
 rmmmod setkey sync vmstat chown dmesg ifconfig ln readtty  
 rotatefb setprop syren watchprops cmp exists iftop log mount  
 notify reboot route sleep wipe

- logcat
- netcfg
- debuggerd

# 6. Init

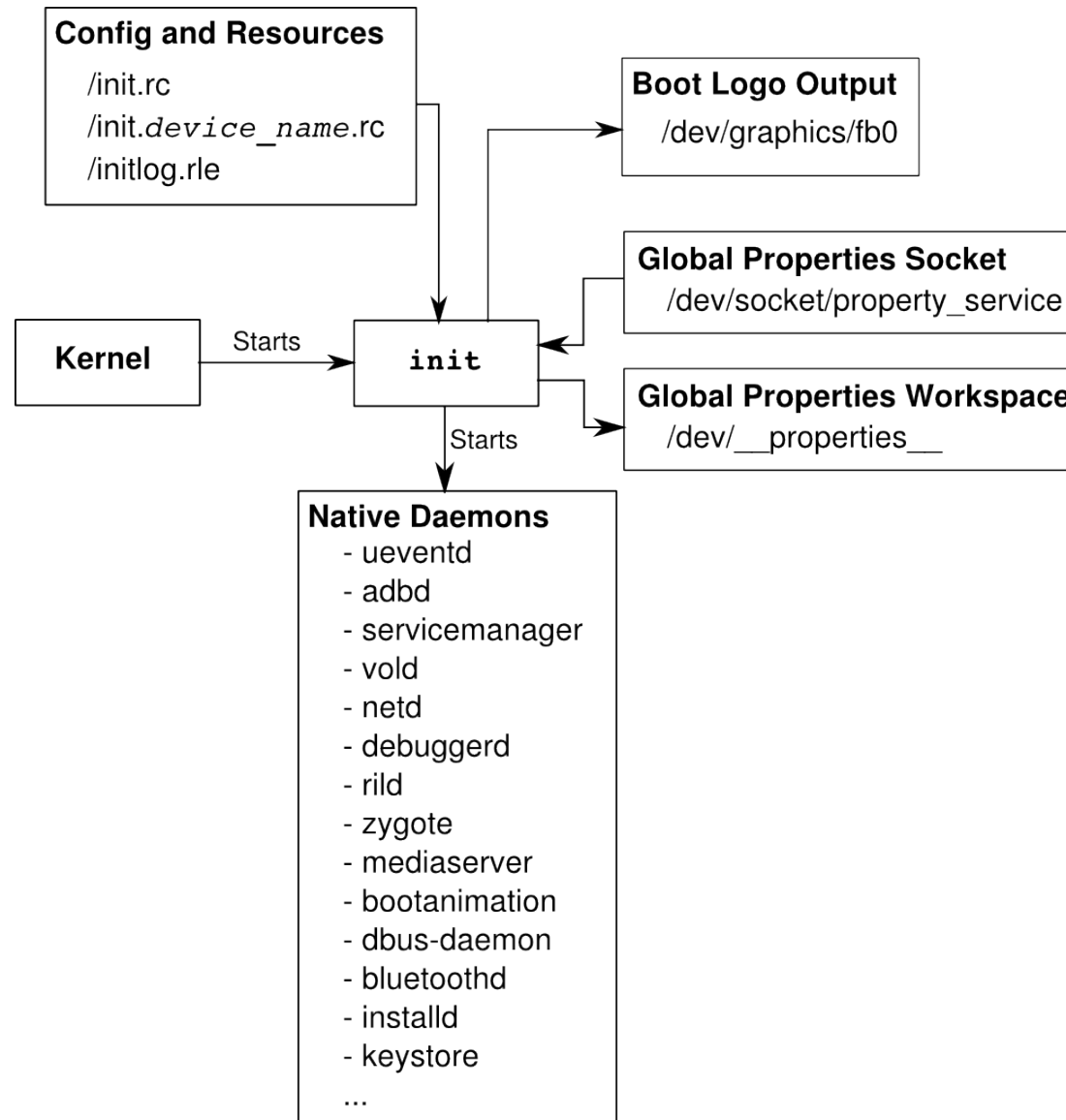

# 6.1. Config files

- Location:
  - /init.rc
  - /init.[board].rc
- Semantics:
  - actions
    - Property triggers
    - Commands
  - services (not related to system services or apps)
    - Parameters

## 6.2. Global properties

- /dev/socket/property\_service
- /dev/\_\_properties\_\_
- foo.bar.property
- ro.\*
- persist.\* => /data/property
- ctl.\*
- net.change

- Std files:
  - /system/build.prop
  - /default.prop
- Other files:
  - /system/default.prop
  - /data/local.prop
- Code:
  - `property_get("dalvik.vm.heapsize", heapsizeOptsBuf+4, "16m");`

# 7. ueventd

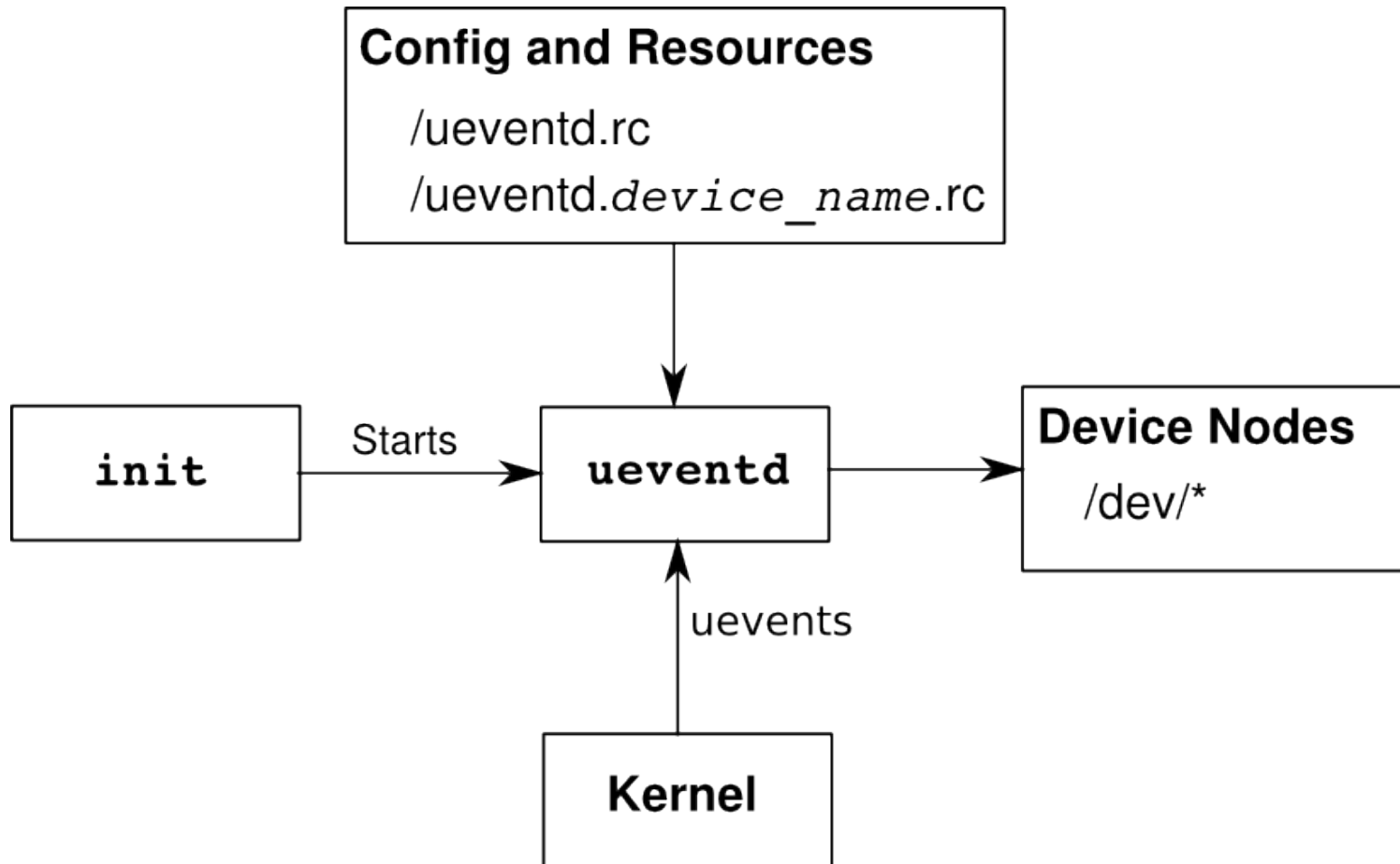

# 7.1. /ueventd.rc

```
/dev/null 0666 root root
```

```
/dev/zero 0666 root root
```

```
/dev/full 0666 root root
```

```
/dev/ptmx 0666 root root
```

```
/dev/tty 0666 root root
```

# 8. Boot logo

```
$ cd device/acme/coyotepad
```

```
$ convert -depth 8 acmelogo.png rgb:acmelogo.raw
```

```
$ rgb2565 -rle < acmelogo.raw > acmelogo.rle
```

# 9. Bionic

- In aosp:
  - /bionic
- In filesystem:
  - /system/lib
- Provides:
  - libc
  - libm
  - libdl
  - libstd++
  - libthread\_db
  - linker

# 10. Tiny Android

```
$ BUILD_TINY_ANDROID=true make -j4
```

- 3MB filesystem
- Minimal root fs
- init
- toolbox + shell
- adb
- bionic + utility libs
- No “system/framework/”
- No “system/app”

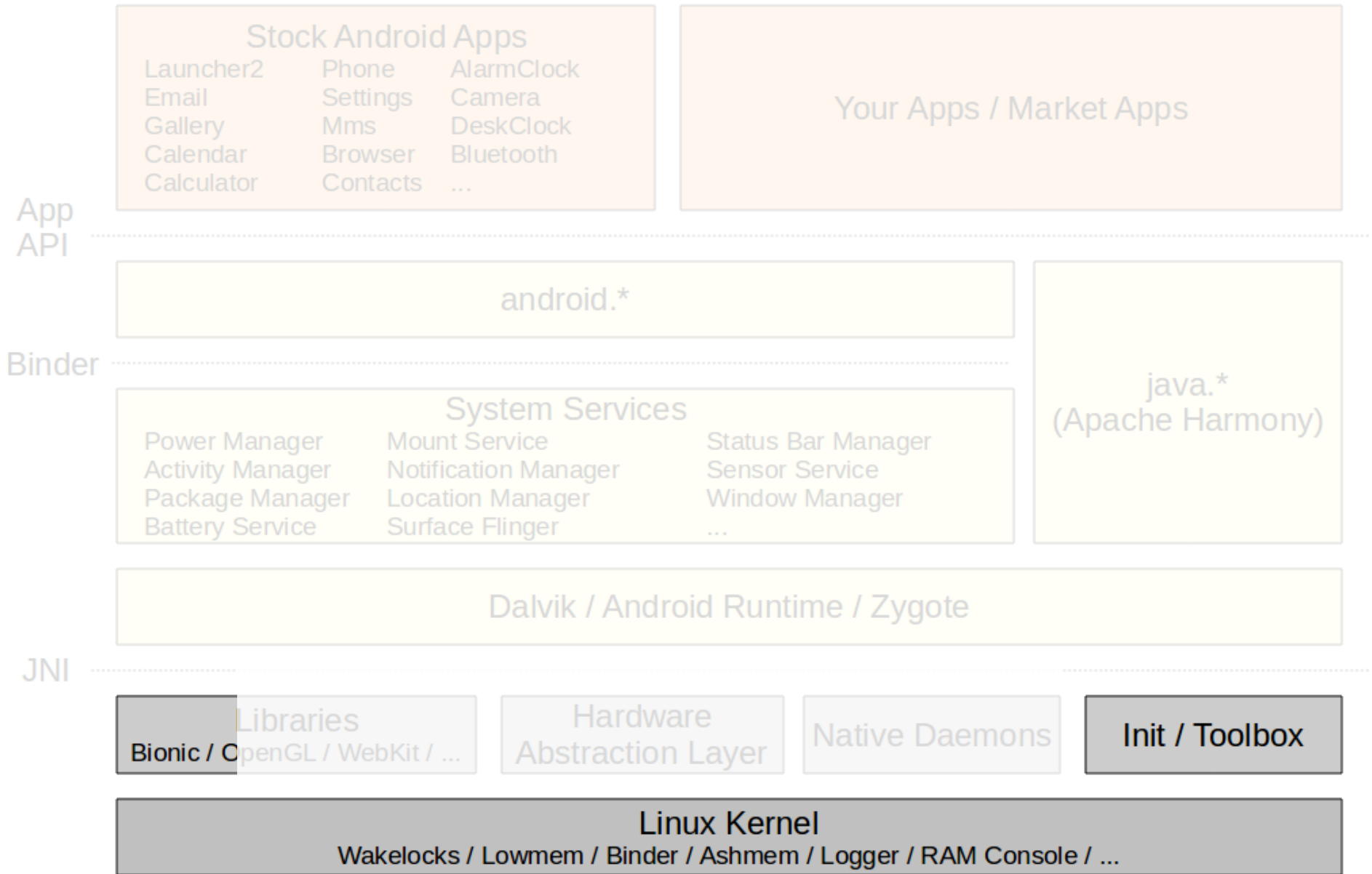

# System Services and Framework Internals

1. Kickstarting the Framework
2. Utilities and Commands
3. Native Daemons
4. System Services Internals
5. Hardware Abstraction Layer
6. Android Framework

# 1. Kickstarting the Framework

- Core building blocks
- System services
- Boot animation
- Dex optimization
- Apps startup

# 1.1. Core building blocks

- Service manager
- Dalvik
- Android runtime
- Zygote

# 1.2. System services

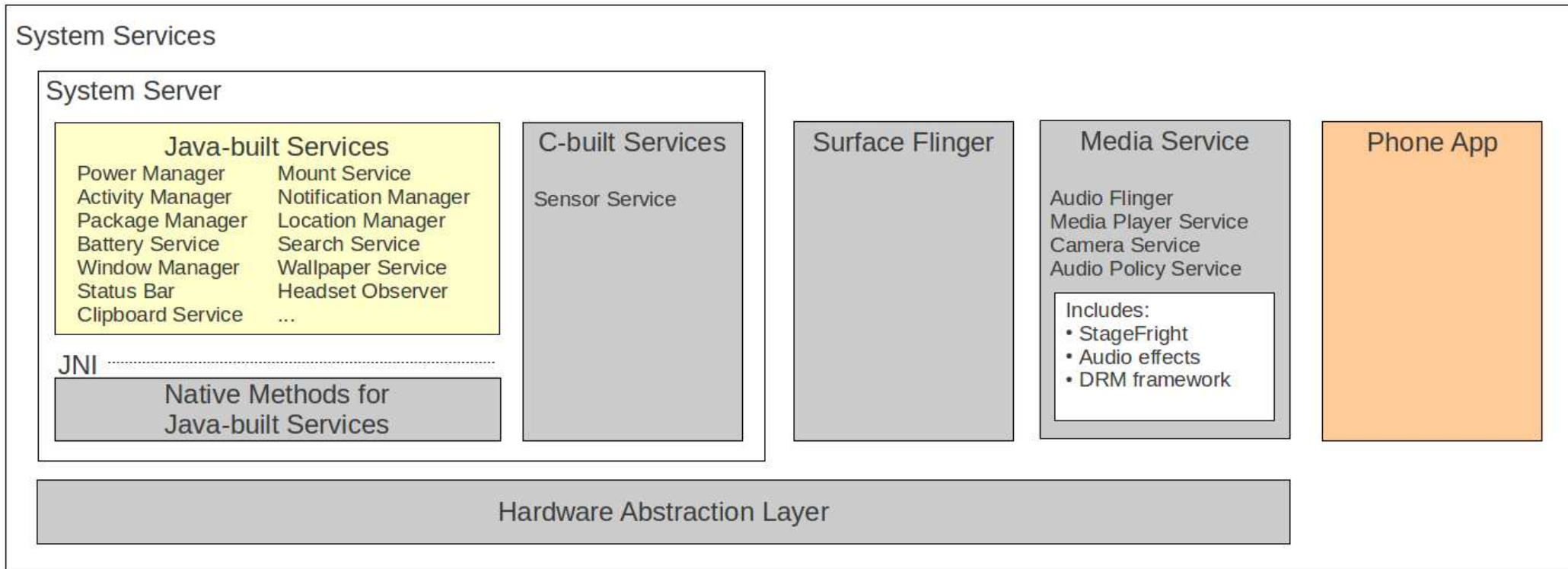

# 1.3. Boot animation

- Default boot animation
- bootanimation.zip
- `setprop debug.sf.nobootanimation 1`

# 1.4. Dex optimization

- Files:
  - .jar
  - .apk
- Directories:
  - BOOTCLASSPATH
  - /system/etc/permission/platform.xml
  - /system/framework
  - /system/app
  - /vendor/app
  - /data/app
  - /data/app-private

# 1.5. Apps startup

- Input methods
- Persistent apps
- Home screen
- BOOT\_COMPLETED intent
- APPWIDGET\_UPDATE intent

# 2. Utilities and Commands

- General-purpose commands
  - service
  - dumphsys
  - dumpstate
  - rawbu
- Service-specific utilities
  - am
  - pm
  - svc

- ime
- input
- monkey
- bmgr
- stagefright
- Dalvik utilities
  - dalvikvm
  - dvz
  - dexdump

# 3. Native daemons

- servicemanager
- installd
- vold
- netd
- rild
- keystore

# 3.1. servicemanager

- In aosp:
  - `/frameworks/base/cmds/servicemanager/`
- In filesystem:
  - `/system/bin/`
- Provides:
  - Context management for binder
  - Service index for entire system

## 3.2. installd

- In aosp:
  - `/frameworks/base/cmds/installd`
- In filesystem:
  - `/system/bin/`
- Provides:
  - Package install/uninstall
  - Sanity checks and verifications
  - Interfaces with Package Manager service

## 3.3. vold

- In aosp:
  - /system/vold/
- In filesystem:
  - /system/bin/
- Provides:
  - Volume mounter
  - Auto-mount
  - Auto-format mounted devices

# 3.4. netd

- In aosp:
  - `/system/netd/`
- In filesystem:
  - `/system/bin/`
- Provides:
  - Management of aspects of networking
  - Interfaces with Network Management service

## 3.5. rild

- In aosp:
  - /hardware/ril/mock-ril/
- In filesystem:
  - /system/bin/
- Provides:
  - “Radio Interface Layer” to phone hardware

# 3.6. keystore

- In aosp:
  - frameworks/base/cmds/keystore/
- In filesystem:
  - /system/bin
- Provides:
  - Store key-value pairs
  - Security keys for connecting to network infrastructure

# 4. System Services Internals

- Services run by System Server
- Observing the System Server
- Calling on system services
- Inside a few system services
- Creating your own system service

# 4.1. Services run by the System Server

Entropy Service  
Power Manager  
Activity Manager  
Telephone Registry  
Package Manager  
Account Manager  
Content Manager  
System Content Providers  
Battery Service  
Lights Service  
Vibrator Service  
Alarm Manager  
Init Watchdog  
Sensor Service  
Window Manager  
Bluetooth Service

Device Policy  
Status Bar  
Clipboard Service  
Input Method Service  
NetStat Service  
NetworkManagement Service  
Connectivity Service  
Throttle Service  
Accessibility Manager  
Mount Service  
Notification Manager  
Device Storage Monitor  
Location Manager  
Search Service  
DropBox Service  
Wallpaper Service

Audio Service  
Headset Observer  
Dock Observer  
UI Mode Manager Service  
Backup Service  
AppWidget Service  
Recognition Service  
*Status Bar Icons*  
DiskStats Service  
ADB Settings Observer

## 4.1.1. Some stats

- frameworks/base/services/java/com/android/server:
  - 3.5 M
  - ~100 files
  - 85 kloc
- Activity manager:
  - 920K
  - 30+ files
  - 20 kloc

# 4.2. Observing the System Server

- Logcat
- dumpsys

# 4.2.1. logcat

- Find the System Server's PID

```
$ adb shell ps | grep system_server  
system 63 32 120160 35408 ffffffff afd0c738 S system_server
```

- Look for its output:

```
$ adb logcat | grep "63)"
```

```
...  
D/PowerManagerService( 63): bootCompleted  
I/TelephonyRegistry( 63): notifyServiceState: 0 home Android Android 310260 UMTS CSS not supp...  
I/TelephonyRegistry( 63): notifyDataConnection: state=0 isDataConnectivityPossible=false reason=null  
interfaceName=null networkType=3  
I/SearchManagerService( 63): Building list of searchable activities  
I/WifiService( 63): WifiService trying to setNumAllowed to 11 with persist set to true  
I/ActivityManager( 63): Config changed: { scale=1.0 imsi=310/260 loc=en_US touch=3 keys=2/1/2 nav=3/1 ...  
I/TelephonyRegistry( 63): notifyMessageWaitingChanged: false  
I/TelephonyRegistry( 63): notifyCallForwardingChanged: false  
I/TelephonyRegistry( 63): notifyDataConnection: state=1 isDataConnectivityPossible=true reason=simL...  
I/TelephonyRegistry( 63): notifyDataConnection: state=2 isDataConnectivityPossible=true reason=simL...  
D/Tethering( 63): MasterInitialState.processMessage what=3  
I/ActivityManager( 63): Start proc android.process.media for broadcast  
com.android.providers.downloads/.DownloadReceiver: pid=223 uid=10002 gids={1015, 2001, 3003}  
I/RecoverySystem( 63): No recovery log file  
W/WindowManager( 63): App freeze timeout expired.  
...
```

# 4.2.2. dumpsys

Currently running services:

SurfaceFlinger

accessibility

account

activity

alarm

appwidget

audio

backup

...

wifi

window

-----  
DUMP OF SERVICE SurfaceFlinger:

+ Layer 0x396b90

z= 21000, pos=( 0, 0), size=( 480, 800), needsBlending=1, needsDithering=1, invalidat ...

0]

name=com.android.launcher/com.android.launcher2.Launcher

client=0x391e48, identity=6

[ head= 1, available= 2, queued= 0 ] reallocMask=00000000, inUse=-1, identity=6, status=0

format= 1, [480x800:480] [480x800:480], freezeLock=0x0, dq-q-time=53756 us

...

# 4.3. Calling on System Services

- Use `getSystemService`
- Ex: NotificationManager Object reference:

```
String ns = Context.NOTIFICATION_SERVICE;
```

```
NotificationManager mNotificationManager = (NotificationManager) \  
getSystemService(ns);
```

- Prepare your content
- Call on the object:

```
mNotificationManager.notify(HELLO_ID, notification);
```

# 4.4. Inside a few System Services

- Get the AOSP ... repo, etc.
- Tricks:
  - Import into Eclipse and collapse methods
  - Use reverse-engineering tools:
    - Imagix
    - Rationale
    - Lattix
    - Scitools
    - ...
- Be patient, this isn't documented anywhere ...

# 4.4.1. ActivityManager

- Start new Activities, Services
- Fetch Content Providers
- Intent broadcasting
- OOM adj. maintenance
- Application Not Responding
- Permissions
- Task management
- Lifecycle management

- Ex. starting new app from Launcher:
  - onClick(Launcher)
  - startActivity(Activity.java)
  - *<Binder>*
  - ActivityManagerService
  - startViaZygote(Process.java)
  - *<Socket>*
  - Zygote

## 4.4.2. Package Manager

- 10 kloc
- 450 K
- Installation / removal
- Permissions
- Intent resolution (also IntentResolver.java)
- Called by Activity Manager

# 4.4.3. Window Manager

- Main thread
- Window manipulation
- Wallpaper handling
- Orientation
- Focus
- Layering
- Input event management

# 4.4.4. Notification Manager

- Toasts
- Notifications
- Sound playback (see NotificationPlayer.java)

# 4.4.5. Power Manager

- Wakelocks
- Sleep
- Brightness
- Lock

# 4.4.6. Network Management Service

- Talks to “netd” /system/netd
- Interface configuration
- Tethering
- DNS

# 4.4.7. Mount Service

- Mount / Unmount
- Format
- USB mass storage
- OBB

## 4.4.8. Location Manager

- Manage location providers
- `getBestProvider()`
- Proximity alerts
- Last known location

## 4.4.9. Status Bar Manager

- Expand / collapse
- Icon visibility
- Reveal callbacks
- Callbacks for notification manager

# 4.4.10. Backup Manager

- Enable / disable
- Transport management
- `backupNow()`
- ...

# 4.5. Creating your own System Service

- Add your code to:  
frameworks/base/services/java/com/android/server/
- Have the SystemServer.java init+reg. your service
- Define hardware API for apps
- Expose through:
  - frameworks/base/core/java/android/os/[server].aidl
- Call on native “driver” code through JNI
- Implement or connect to appropriate driver
- Create an app that calls on service
- May need to create new SDK ...

# 4.5.1. OpersysService.java

```
package com.android.server;

import android.content.Context;
import android.os.Handler;
import android.os.IOpersysService;
import android.os.Looper;
import android.os.Message;
import android.os.Process;
import android.util.Log;

public class OpersysService extends IOpersysService.Stub {
    private static final String TAG = "OpersysService";
    private OpersysWorkerThread mWorker;
    private OpersysWorkerHandler mHandler;
    private Context mContext;

    public OpersysService(Context context) {
        super();
        mContext = context;
        mWorker = new OpersysWorkerThread("OpersysServiceWorker");
        mWorker.start();
        Log.i(TAG, "Spawned worker thread");
    }

    public void setValue(int val) {
        Log.i(TAG, "setValue " + val);
        Message msg = Message.obtain();
        msg.what = OpersysWorkerHandler.MESSAGE_SET;
        msg.arg1 = val;
        mHandler.sendMessage(msg);
    }
}
```

```

private class OpersysWorkerThread extends Thread{
public OpersysWorkerThread(String name) {
    super(name);
}

public void run() {
    Looper.prepare();
    mHandler = new OpersysWorkerHandler();
    Looper.loop();
}

private class OpersysWorkerHandler extends Handler {
private static final int MESSAGE_SET = 0;

@Override
public void handleMessage(Message msg) {
    try {
        if (msg.what == MESSAGE_SET) {
            Log.i(TAG, "set message received: " + msg.arg1);
        }
    }
    catch (Exception e) {
        // Log, don't crash!
        Log.e(TAG, "Exception in OpersysWorkerHandler.handleMessage:", e);
    }
}
}
}

```

## 4.5.2. IOpersysService.aidl

```
package android.os;
/**
 * {@hide}
 */
interface IOpersysService {
void setValue(int val);
}
```

## 4.5.3. frameworks/base/Android.mk

...

```
core/java/android/os/IPowerManager.aidl \  
core/java/android/os/IOperSystemService.aidl \  
core/java/android/os/IRemoteCallback.aidl \  
...
```

...

# 4.5.4. SystemServer.java

Should eventually be Context.OPERSYS\_SERVICE

...

```
try {
    Slog.i(TAG, "Opersys Service");
    ServiceManager.addService("opersys", new OpersysService(context));
} catch (Throwable e) {
    Slog.e(TAG, "Failure starting OpersysService Service", e);
}
```

...

# 4.5.5. HelloServer.java

```
package com.opersys.helloserver;

import android.app.Activity;
import android.os.Bundle;
import android.os.ServiceManager;
import android.os.IOpersysService;
import android.util.Log;

public class HelloServer extends Activity {
    private static final String DTAG = "HelloServer";

    /** Called when the activity is first created. */
    @Override
    public void onCreate(Bundle savedInstanceState) {
        super.onCreate(savedInstanceState);
        setContentView(R.layout.main);

        IOpersysService om =
IOpersysService.Stub.asInterface(ServiceManager.getService("opersys"));
        try {
            Log.d(DTAG, "Going to call service");
            om.setValue(20);
            Log.d(DTAG, "Service called succesfully");
        }
        catch (Exception e) {
            Log.d(DTAG, "FAILED to call service");
            e.printStackTrace();
        }
    }
}
```

# 5. Hardware Abstraction Layer

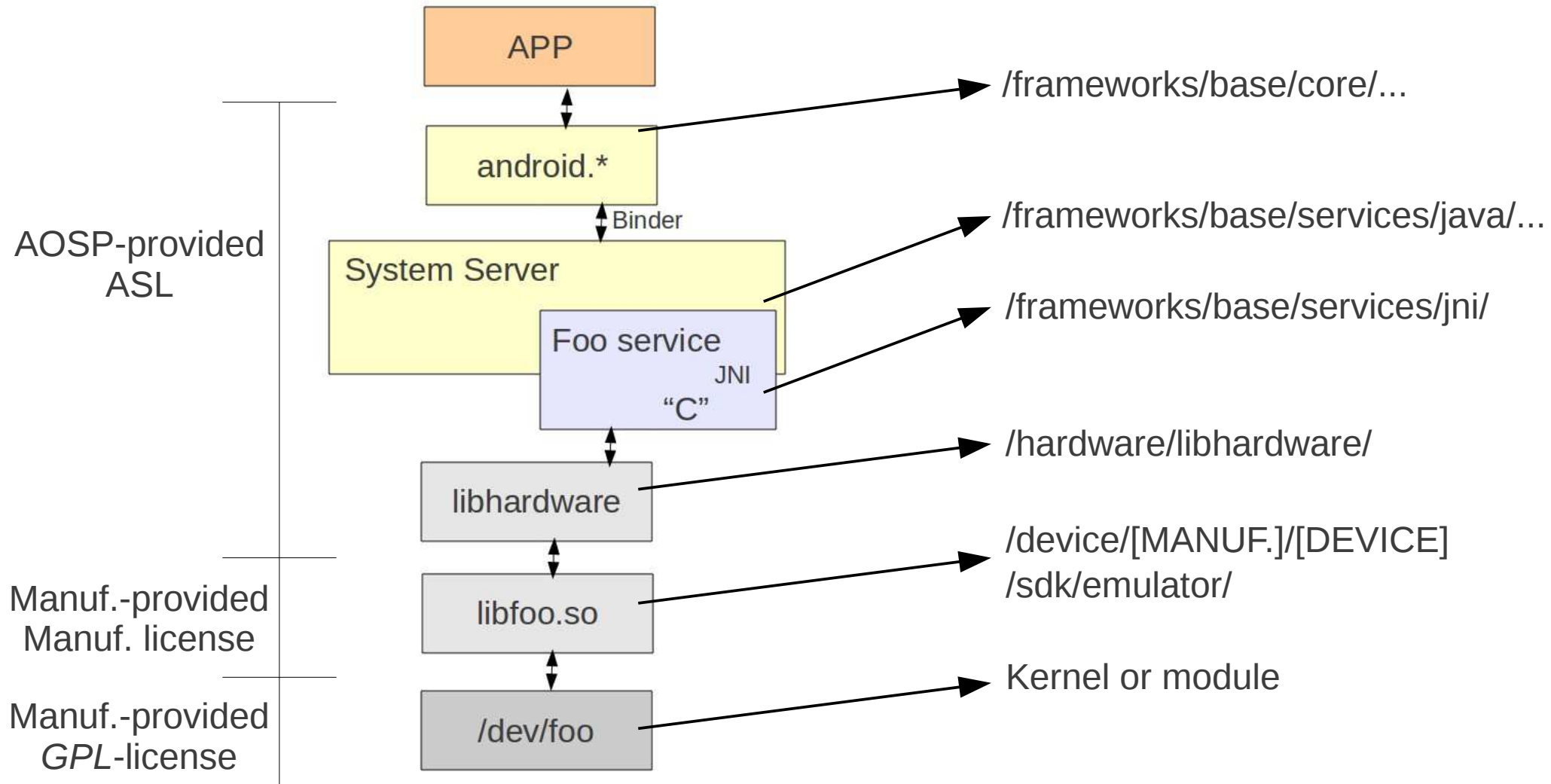

- [aosp]/hardware/libhardware/include/hardware
  - gps.h
  - lights.h
  - sensors.h
- [aosp]/hardware/ril/include/telephony/
  - ril.h
- Examples in [aosp]/device/\*/\*
- Using JNI to call C functions

# 6. Android Framework

- Location and components
- android.\*
- Customization

# 6.1. Location and components

- [aosp]/frameworks/base
  - /cmds => native cmds and daemons
  - /core => android.\* and com.android.\*
  - /data => Fonts and sounds
  - /graphics => 2D & Renderscript
  - /include => "C" includes
  - /keystore => security key store
  - /libs => "C" libraries
  - /location => Location provider
  - /media => Stagefright, codecs, etc.
  - /native => Native code for some frameworks components
  - /obex => Bluetooth obex
  - /opengl => GL library and java code
  - /packages => A few core packages (Status Bar)
  - /services => System server
  - /telephony => Phone related functionality
  - /tools => A few core tools (aapt, aidl, ...)
  - /voip => RTP & SIP interfaces
  - /vpn => VPN functionality
  - /wifi => Wifi manager, monitor, etc.

## 6.2. android.\*

accessibilityservice	content	hardware	pim	speech
accounts	database	inputmethodservice	preference	test
annotation	ddm	net	provider	text
app	debug	nfc	security	util
appwidget	emoji	os	server	view
bluetooth	gesture	service	webkit	widget

# 6.3. Customization

- Extending API
- Boot screen
- Status bar
- Network
- Preloaded apps
- Browser bookmarks
- Email provider customization
- Themes

# 6.3.1. Extending API – System service

- frameworks/base/core/java/android/
  - app/ContextImpl.java
  - content/Context.java
  - os/OpersysManager.java

## 6.3.1.1. app/ContextImpl.java

```
...
import android.os.IOpersysService;
import android.os.OpersysManager;
...

    registerService(OPERSYS_SERVICE, new ServiceFetcher() {
        public Object createService(ContextImpl ctx) {
            IBinder b =
                ServiceManager.getService(OPERSYS_SERVICE);
            IOpersysService service =
                IOpersysService.Stub.asInterface(b);
            return new OpersysManager(service);
        }
    });
...

```

## 6.3.1.2. content/Context.java

```
...  
/**  
 * Use with {@link #getSystemService} to retrieve a  
 * {@link android.nfc.NfcManager} for using NFC.  
 *  
 * @see #getSystemService  
 */  
public static final String NFC_SERVICE = "nfc";  
  
/** The Opersys service */  
public static final String OPERSYS_SERVICE = "opersys";  
...
```

# 6.3.1.3. os/OpersysManager.java

```
package android.os;

import android.os.IOpersysService;

public class OpersysManager
{
    public void setValue(int value)
    {
        try {
            mService.setValue(value);
        } catch (RemoteException e) {
        }
    }

    public String read(int maxLength) {...}

    public int write(String stringVal) {...}

    public OpersysManager(IOpersysService service)
    {
        mService = service;
    }

    IOpersysService mService;
}
```

## 6.3.2. Status bar

- Location:
  - frameworks/base/packages/SystemUI/src/com/android/systemui/statusbar
- Disable phone signal - SignalClusterView.java:

```
if (mMobileVisible && !mIsAirplaneMode) {  
    /* DISABLE  
    mMobileGroup.setVisibility(View.VISIBLE);  
    mMobile.setImageResource(mMobileStrengthId);  
    mMobileActivity.setImageResource(mMobileActivityId);  
    mMobileType.setImageResource(mMobileTypeId);  
    mMobileGroup.setContentDescription(mMobileTypeDescription + ...  
    */
```

- Disable battery meter -  
policy/BatteryController.java:

```
/* DISABLE
for (int i=0; i<N; i++) {
    ImageView v = mIconViews.get(i);
    v.setImageResource(icon);
    v.setImageLevel(level);
    v.setContentDescription(mContext.getString(R.string.acces...
}
*/
```

# 6.3.3. Network

- Locations:
  - Global static:
    - frameworks/base/core/res/res/xml/apns.xml
  - Device static:
    - PRODUCT\_COPY\_FILES := vendor/acme/etc/apns-conf-us.xml:system/etc/apns-conf.xml
  - Dynamic:
    - system/etc/apns-conf.xml
- Format:

```
<apn carrier="T-Mobile US"  
    mcc="310"  
    mnc="260"  
    apn="wap.voicestream.com"  
    user="none"  
    server=""  
    password="none"  
    proxy="216.155.165.50"  
    port="8080"  
    mmsc="http://216.155.174.84/servlets/mms"  
>
```

## 6.3.4. Browser bookmarks

- See `packages/apps/Browser/res/values/strings.xml`

```
<!-- Bookmarks -->
```

```
<string-array name="bookmarks">
```

```
  <item>Google</item>
```

```
  <item>http://www.google.com/</item>
```

```
  <item>Yahoo!</item>
```

```
  <item>http://www.yahoo.com/</item>
```

```
  <item>MSN</item>
```

```
  <item>http://www.msn.com/</item>
```

```
  <item>MySpace</item>
```

```
  <item>http://www.myspace.com/</item>
```

```
...
```

# 6.3.5. Email provider customization

- See packages/apps/Email/res/xml/providers.xml

```
<!-- Gmail variants -->
```

```
<provider id="gmail" label="Gmail" domain="gmail.com">  
  <incoming uri="imap+ssl+://imap.gmail.com" username="$email"/>  
  <outgoing uri="smtp+ssl+://smtp.gmail.com" username="$email"/>  
</provider>
```

```
<provider id="googlemail" label="Google Mail" domain="googlemail.com">  
  <incoming uri="imap+ssl+://imap.googlemail.com" username="$email"/>  
  <outgoing uri="smtp+ssl+://smtp.googlemail.com" username="$email"/>  
</provider>
```

```
...
```

```
<!-- Common US providers -->
```

```
<provider id="aim" label="AIM" domain="aim.com">  
  <incoming uri="imap://imap.aim.com" label="IMAP" username="$email"/>  
  <outgoing uri="smtp://smtp.aim.com:587" username="$email"/>  
</provider>
```

```
<provider id="aol" label="AOL" domain="aol.com">  
  <incoming uri="imap://imap.aol.com" label="IMAP" username="$email"/>  
  <outgoing uri="smtp://smtp.aol.com:587" username="$email"/>  
</provider>
```

```
...
```

## 6.3.6. Themes

- See `framework/base/core/res/res/values/styles.xml`

# Inside Android's UI

- Android's UI, what's that?
- Architecture Basics
- Display Core
- OpenGL
- Input Layer
- Relevant Apps and Services
- System Startup
- References and Pointers

# 1. Android's UI, what's that?



- SoC / GPU
- Touch input
- LCD
- Keyboard

# 1.1. What's NOT covered here

- Media layer
- StageFright
- Video playback
- Camera
- DRM
- Etc.

## 2. Architecture Recap

- Hardware used to run Android
- AOSP
- Binder
- System Services
- HAL

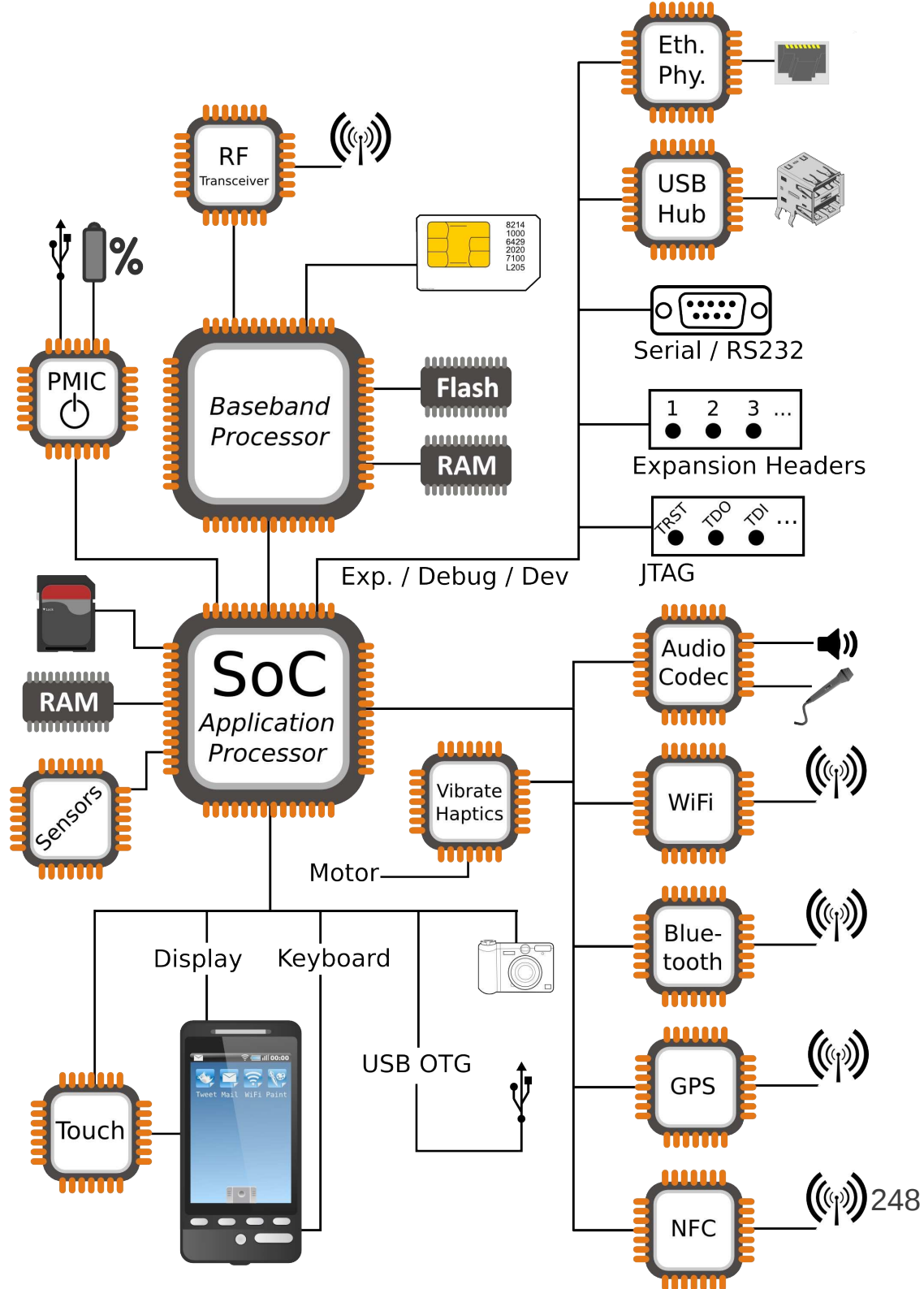

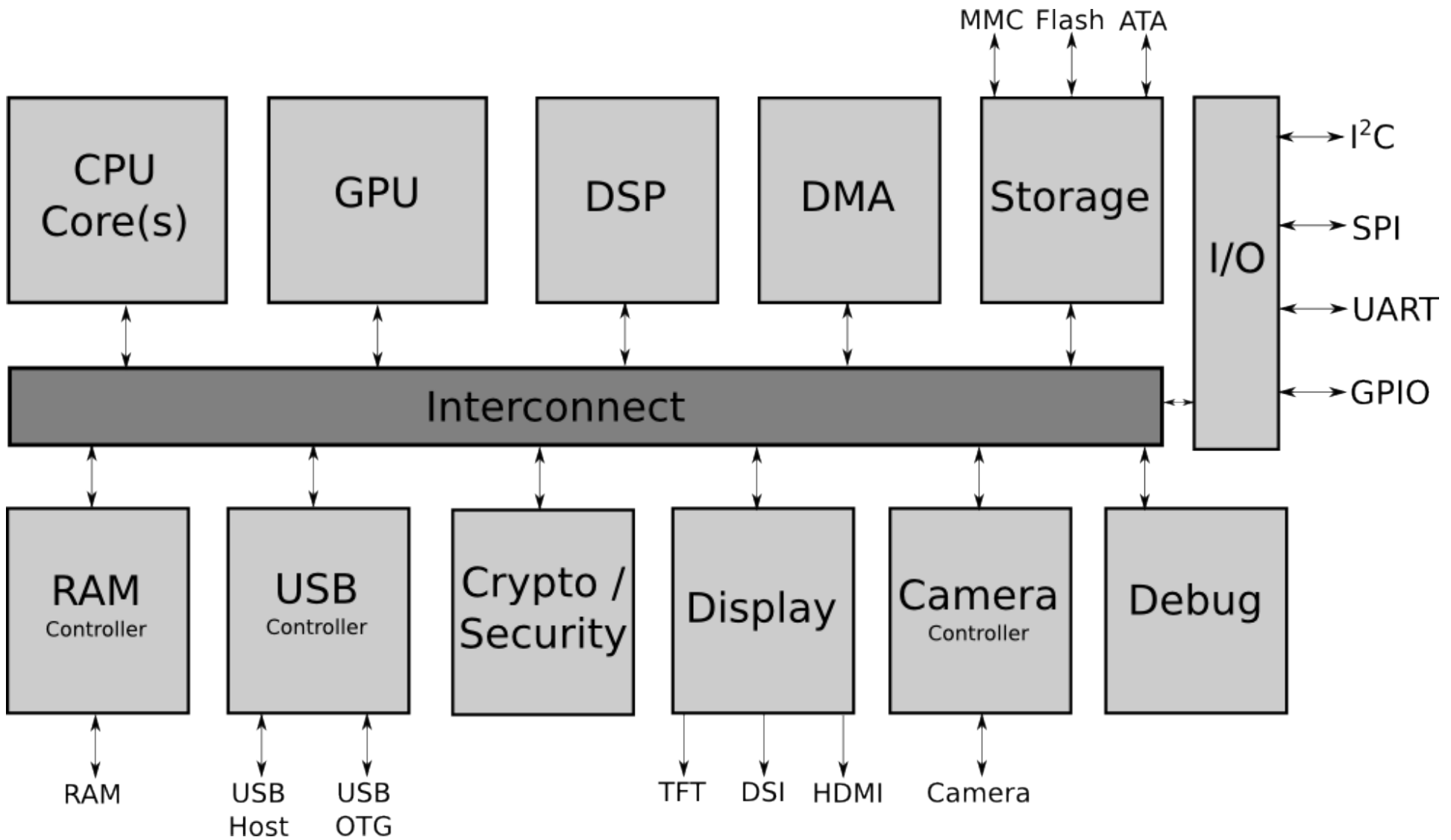

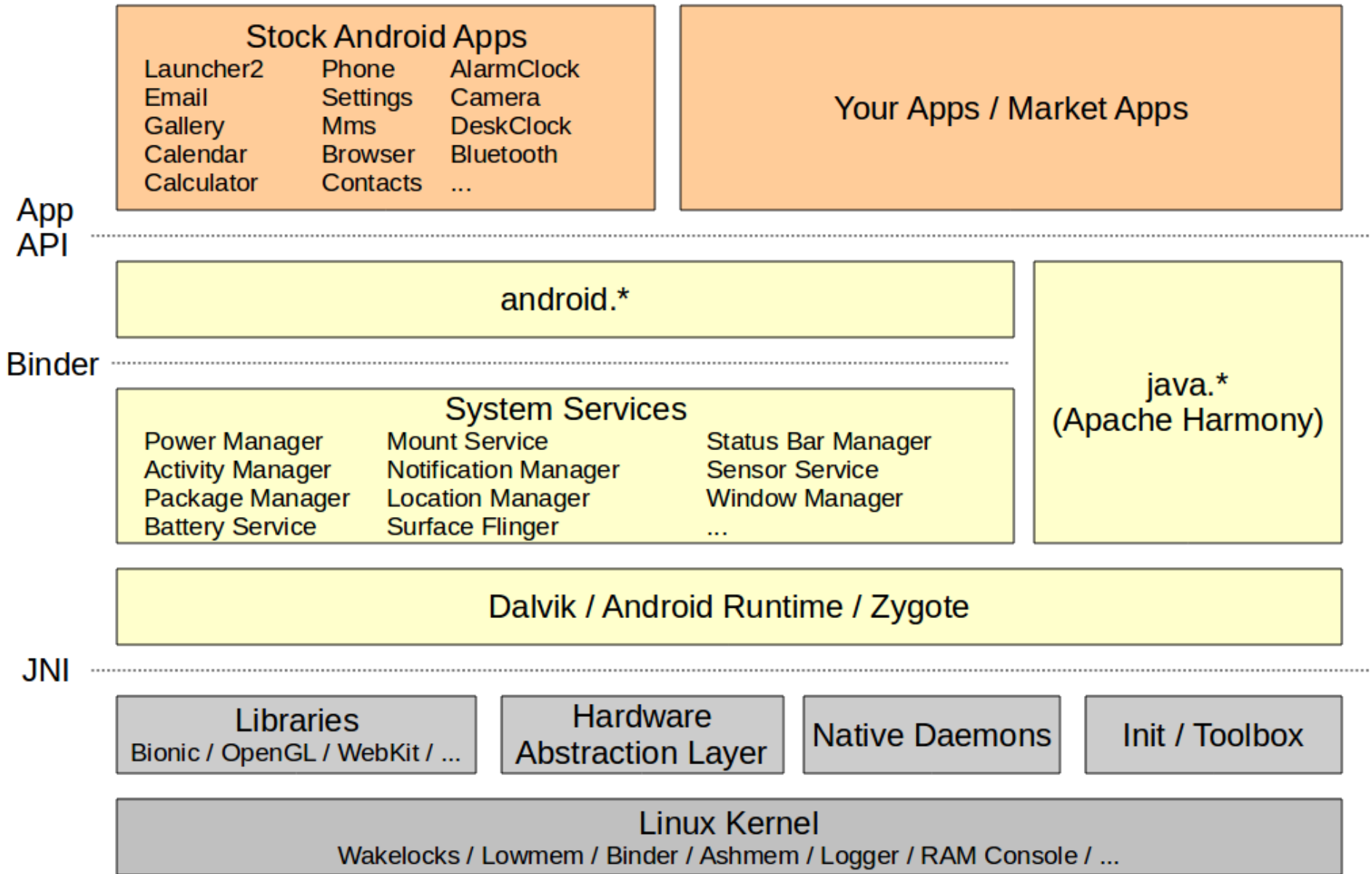

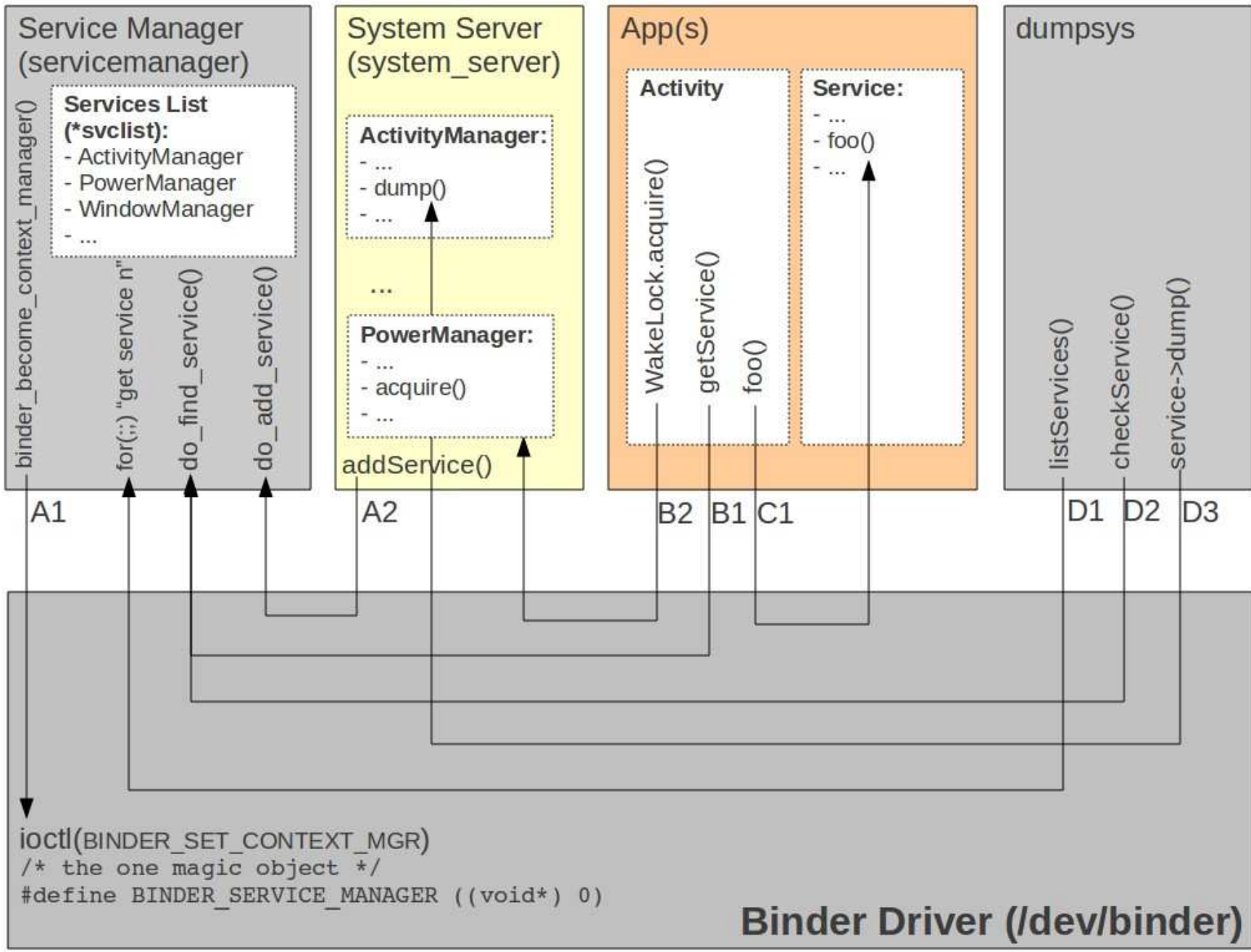

## System Services

### System Server

#### Java-built Services

Power Manager	Mount Service
Activity Manager	Notification Manager
Package Manager	Location Manager
Battery Service	Search Service
Window Manager	Wallpaper Service
Status Bar	Headset Observer
Clipboard Service	...

#### C-built Services

Sensor Service

#### Surface Flinger

#### Media Service

Audio Flinger  
Media Player Service  
Camera Service  
Audio Policy Service

##### Includes:

- StageFright
- Audio effects
- DRM framework

#### Phone App

JNI

Native Methods for  
Java-built Services

Hardware Abstraction Layer

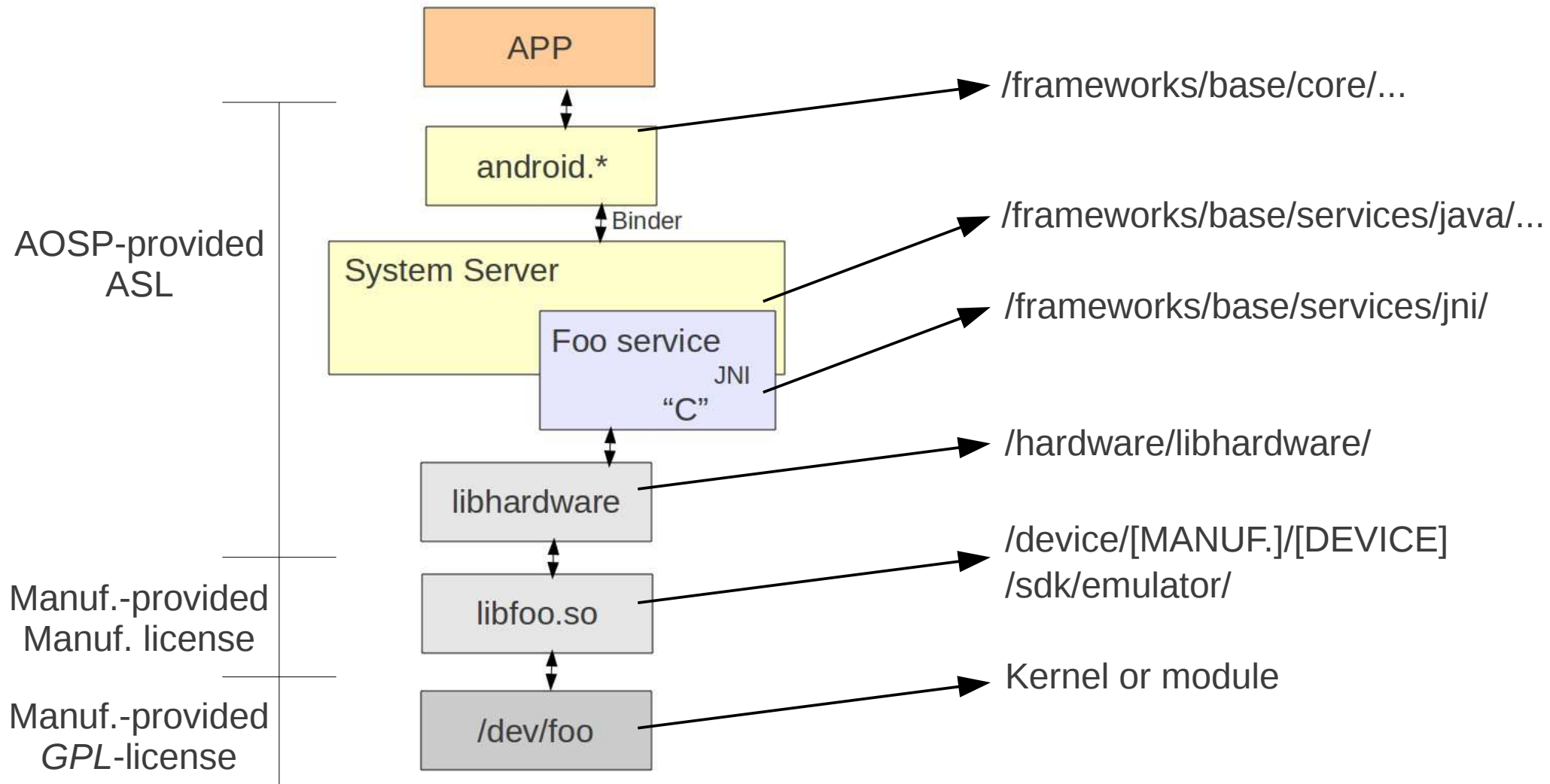

# 3. Display Core

- Display Hardware
- Classic Linux display stack
- Display stack in Android
- Kernel driver
- HAL definition
- HAL module
- Surface Flinger
- Window Manager
- Walkthrough

# 3.1. Display Hardware

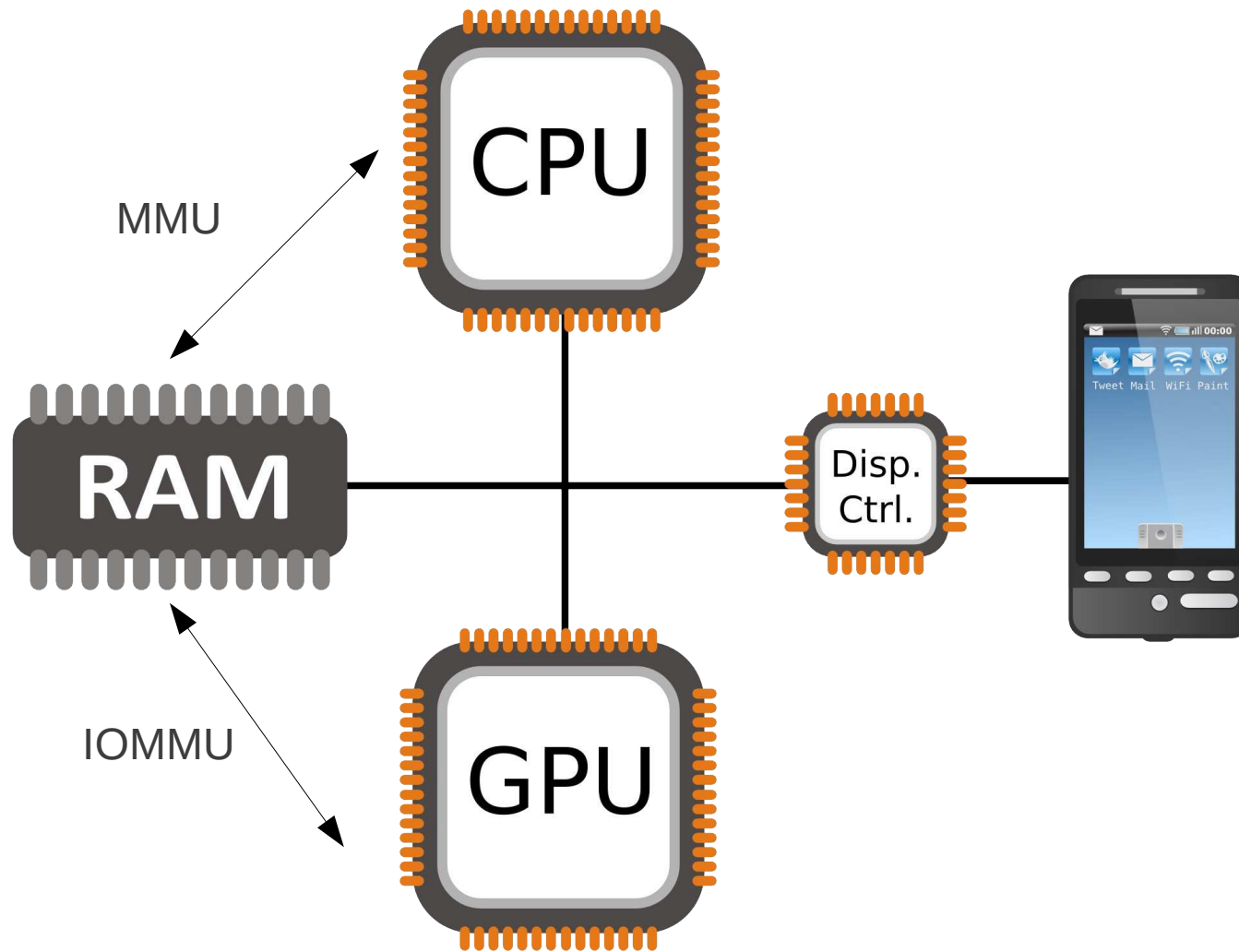

# 3.2. Classic Linux display stack

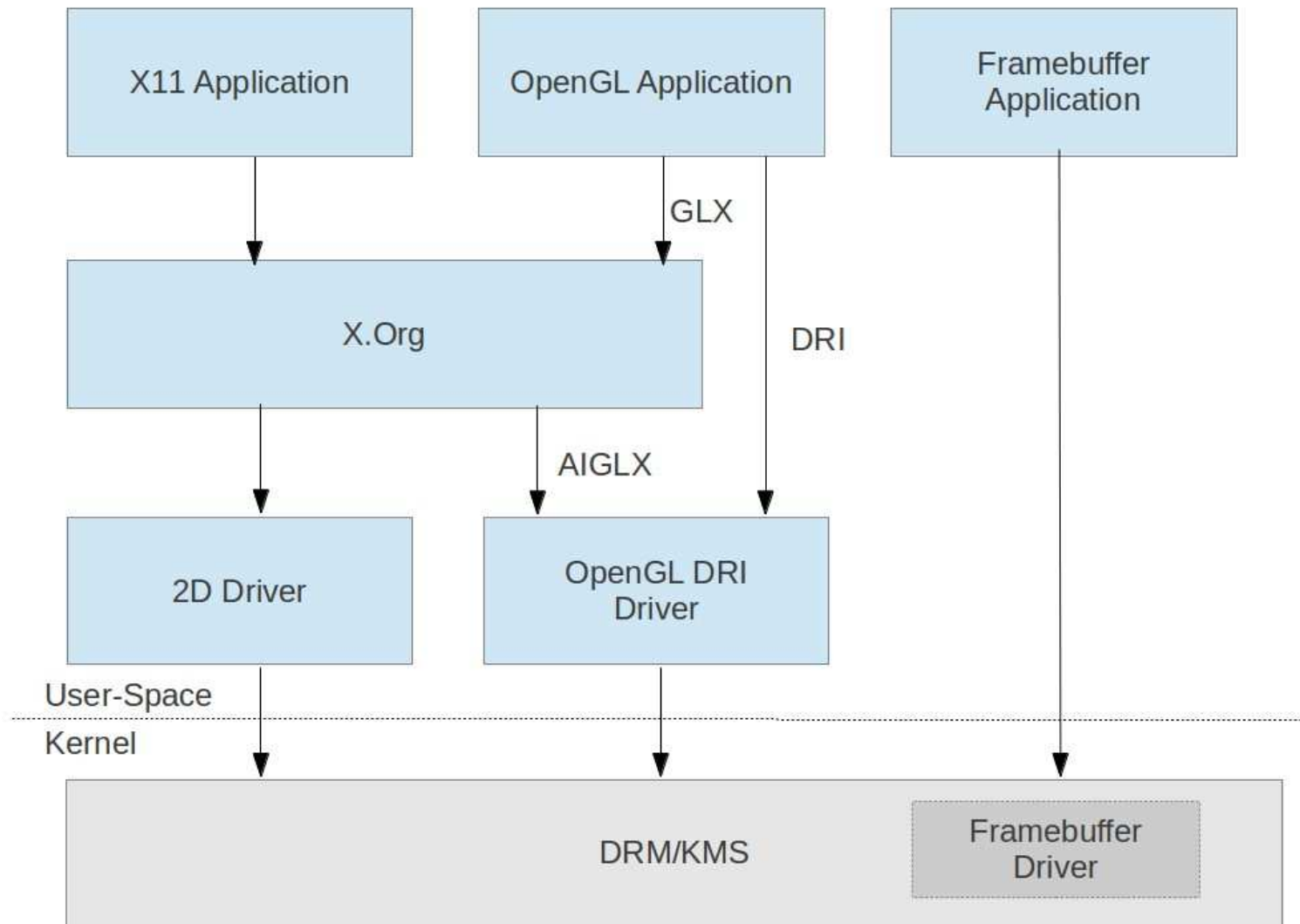

# 3.3. Display stack in Android

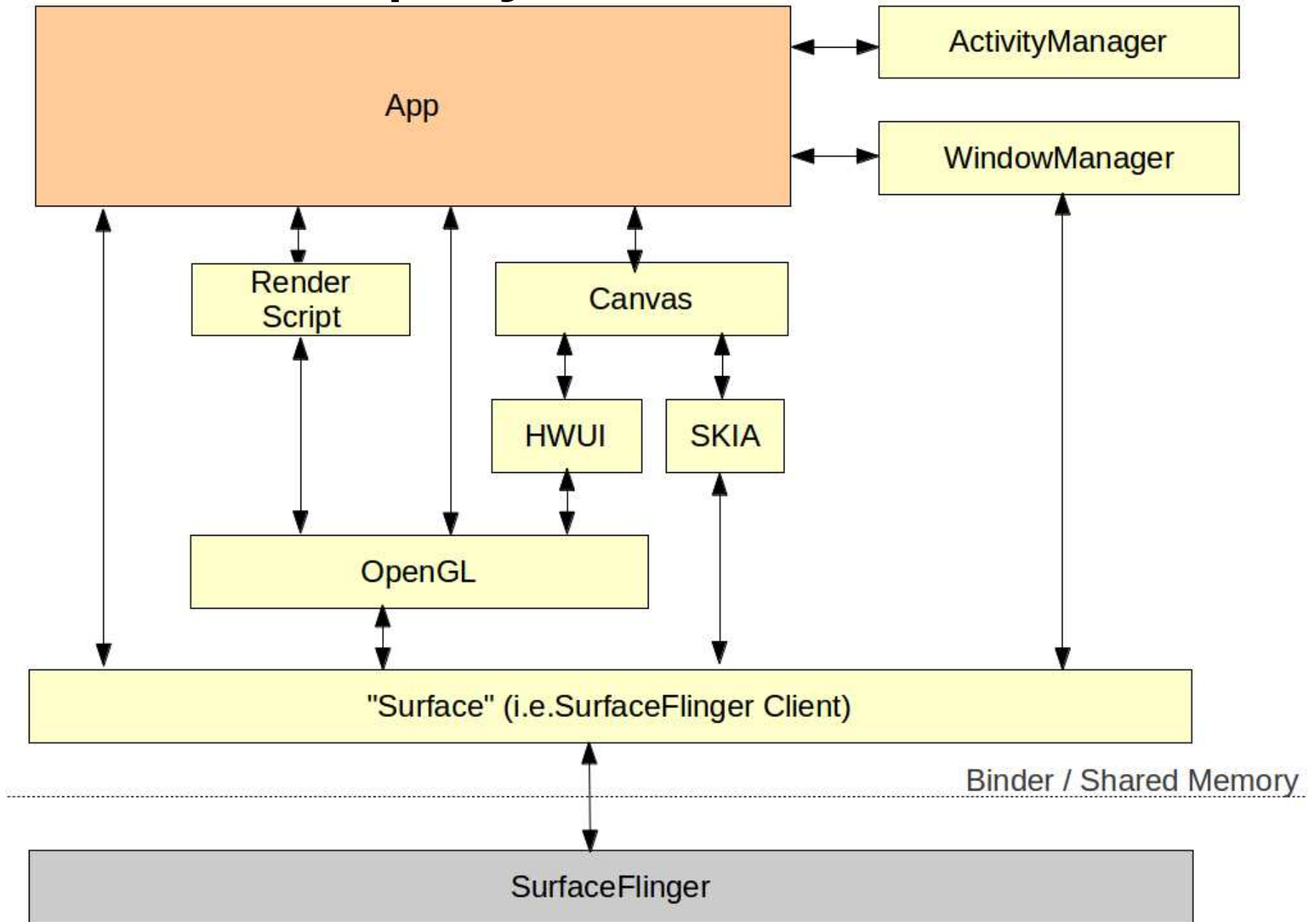

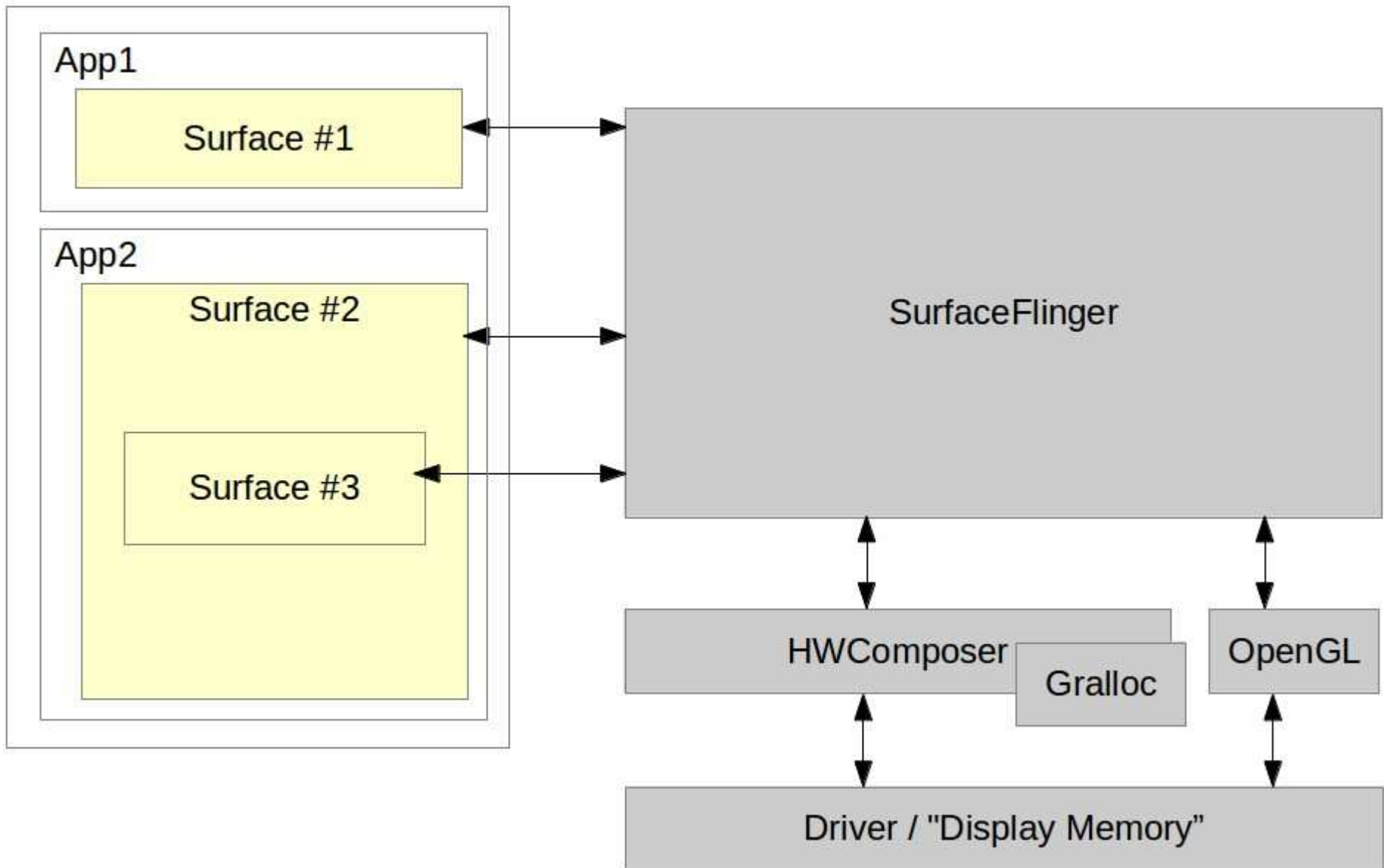

# 3.4. Kernel driver

- Video memory management
- Mode setting
- Checking of parameters
- Motorola Xoom:
  - /dev/nvhdcpl
  - /dev/nvhost-ctrl
  - /dev/nvhost-display
  - /dev/nvhost-dsi
  - /dev/nvhost-gr2d
  - /dev/nvhost-gr3d
  - /dev/nvhost-isp
  - /dev/nvhost-mpe
  - /dev/nvhost-vi
  - /dev/nvmap
  - /dev/tegra-crypto
  - /dev/tegra\_avp
  - /dev/tegra\_camera
  - /dev/tegra\_fuse
  - /dev/tegra\_rpc
  - /dev/tegra\_sema
- ... whatever hides in hwcomposer HAL module

# 3.5. HAL Definition

- /hardware/libhardware/include/hardware/hwcomposer.h
- struct hwc\_procs:
  - invalidate()
  - vsync()
- struct hwc\_composer\_device:
  - prepare()
  - set()
  - dump()
  - registerProcs()
  - query()
  - \*()

# 3.6. HAL module

- Skeleton `/hardware/libhardware/modules/hwcomposer.cpp`
- `/system/lib/hw/hwcomposer.BOARD.so`
- `/system/lib/hw/gralloc.BOARD.so`
- Ex. - Mot Xoom:
  - `hwcomposer.tegra.so`
  - `gralloc.tegra.so`
- Surface Flinger hook:
  - `/frameworks/native/services/surfaceflinger/DisplayHardware`
    - `HWComposer.cpp`
    - Provides fake vsync if none is provided in HW

# 3.7. Surface Flinger

- Actual server:
  - /frameworks/native/services/surfaceflinger
- Client side:
  - /frameworks/native/libs/gui
- Client / Server interface:
  - ISurfaceComposerClient.cpp
  - ISurfaceComposer.cpp
- This is NOT an aidl'ed service
- All communication is manually marshalled/unmarshalled

# 3.8. Window Manager

- Server side:
  - /frameworks/base/services/java/com/android/server/wm/
    - WindowManagerService.java
    - Session.java
- Client side:
  - /frameworks/base/core/java/android/view/
    - WindowManager.java
    - WindowManagerImpl.java
    - ViewRootImpl.java
- Interfaces:
  - IWindowManager.aidl
  - IWindowSession.aidl
- Parameters (incl. z-order):
  - See WindowManager.java

# 3.9. Walkthrough

- Activity Manager relies on Activity Thread
- AT calls on `attach()` and `makeVisible()`
- `makeVisible` does `wm.addView()`
- `wm.addView()` - this also called by `StatusBar` to display itself
  - Creates a new `ViewRootImpl`
  - Call on its `setView()`
- `setView()` calls on `mWindowSession.addToDisplay(...)`
- This results in call to WM's `addWindow()`
- `ViewRootImpl`'s `performTraversals()`
  - Calls on `layoutWindow()`
  - Calls to WM session's `layout()`
  - Call to WM's `layoutWindow()`
  - Call to `createSurfaceLocked()`
  - `new Surface(...)`

frameworks/base/core/java/android/\*\*

LocalActivityManager.java: startActivity()

- moveToState()
- startActivityNow()

ActivityThread.java: startActivityNow()

- performLaunchActivity()
- attach() -- gets AM handle and ties to it
- handleResumeActivity()
- makeVisible()

Activity.java: makeVisible()

- wm.addView()

WindowManagerGlobal.java: addView()

- root = new ViewRootImpl()
- root.setView()

ViewRootImpl.java: setView()

- mWindowSession.addToDisplay()

IWindowSession.aidl: addToDisplay()

frameworks/base/services/java/com/android/server/wm/\*

Session.java: addToDisplay()

- mService.addWindow()

WindowManagerService.java: addWindow()

...

frameworks/base/core/java/android/\*/\*

ViewRootImpl.java: performTraversals()

- relayWindow()

- mWindowSession.relayout()

frameworks/base/services/java/com/android/server/wm/\*

Session.java: relayWindow()

- mService.relayWindow()

WindowManagerService.java: relayWindow()

- surface = winAnimator.createSurfaceLocked();

WindowStateAnimator.java: createSurfaceLocked()

- new Surface();

# 4. OpenGL

- What's OpenGL?
- What's in a modern-day GPU?
- Software layers involved
  - Kernel driver
  - EGL libs
  - Native interface
  - Java interface
- Software GL implementation

# 4.1. What's OpenGL?

- It's just an API ... nothing but an API ...
- Check out Wikipedia
- Multiple versions out
- “ES” versions for embedded use
- Up to ES 3.0
- Android support up to ES 2.0

## 4.2. What's in a modern-day GPU?

- A tremendous amount of parallel processing units
- “SIMD”-like instruction set
- Video decoding/encoding capabilities
- ...

## 4.3. Software layers involved

- Kernel driver
- GL libraries
- Native GL API
- Java GL API

## 4.4. Kernel driver

**PROPRIETARY**

# 4.5. EGL libs

- /frameworks/base/native/opengl/libs
- Entry point: /system/lib/libEGL.so
- Looks for /system/lib/egl/egl.cfg
- /system/lib/egl - Mot Xoom:
  - egl.cfg
  - libEGL\_perfhud.so
  - libEGL\_tegra.so
  - libGLES\_android.so
  - libGLESv1\_CM\_perfhud.so
  - libGLESv1\_CM\_tegra.so
  - libGLESv2\_perfhud.so
  - libGLESv2\_tegra.so
- elg.cfg:
  - 0 0 tegra

# 4.6. Native interface

- /frameworks/native/opengl/include
  - EGL
  - ETC1
  - GLES
  - GLES2
  - KHR

# 4.7. Java interface

- GL libs required by libandroid\_runtime.so
- /frameworks/base/opengl/java/android/opengl:
  - ...

# 4.8. Software GL implementation

- `/frameworks/native/opengl/libagl`

# 5. Input Layer

- Kernel side - “std” Linux input layer:
  - `/dev/input/*`
- No HAL use
- Native lib:
  - `libinput`
  - `/frameworks/base/services/input`
- Input Manager Service:
  - `/frameworks/base/services/java/com/android/server/input`
  - Started and directly tied to Window Manager
- Specific config files (see [source.android.com](http://source.android.com))
- Soft keyboard:
  - `/frameworks/base/core/java/android/inputmethodservice`
- Input methods:
  - `/packages/inputmehods`
  - <http://developer.android.com/guide/topics/text/creating-input-method.html>

# 6. Relevant Apps and Services

- Launcher
- StatusBar
- Wallpaper Manager Service
- Notification Service
- App Widgets

# 6.1. Launcher

- An app like any other
- See `/packages/app/Launcher2`

## 6.2. StatusBar

- A unique app
- See `/frameworks/base/packages/SystemUI`
- Connects to Status Bar Manager and gives an interface it can use to call back into Status Bar
- Can use `setIcon()` to display icons on the right
- Provides a CPU usage add-on that renders straight on rest of display using higher z-order

## 6.3. Wallpaper Manager Service

- See `/frameworks/base/services/java/com/android/server/WallpaperManagerService.java`

# 6.4. Notification Service

- Toasts
- Status bar notifications
- Gets handle to Status Bar Service at instantiation
- Uses handle to communicate with Status Bar

# 6.5. App Widgets

- See `/frameworks/base/services/java/com/android/server/AppWidgetService.java`

# 7. System Startup

- Kernel
- Init
- Boot animation
- Launcher

# 7.1. Boot animation

- Started by Surface Flinger
- “bootanim” binary
- /frameworks/base/cmds/bootanimation
- Relies on bootanimation.zip w/ PNGs (nothing but)
- See [https://github.com/CyanogenMod/android\\_vendor\\_cm/tree/jellybean/prebuilt/common/bootanimation](https://github.com/CyanogenMod/android_vendor_cm/tree/jellybean/prebuilt/common/bootanimation)
- Must contain a desc.txt:
  - <width> <height> <fps>
  - p <count> <pause> <path>
  - p <count> <pause> <path>

# 8. References and Pointers

- “Use the source, Luke”
- Jim Huang's “Android Graphics”
- Benjamin Zores' “Linux Magazine / France” articles
- MIPS article on graphics internals:  
<http://developer.mips.com/2012/04/11/learning-about-android-graphics-subsystem/>
- Stéphane Marchesin's “Linux Graphics Drivers: an Introduction”  
<http://source.android.com/tech/input/index.html>

# Running Code in Android

1. Programming Languages
2. Standard App Mechanisms
3. Special App Mechanisms
4. Starting Apps
5. Native Utilities and Daemons
6. Java Utilities (and Daemons)
7. System Services
8. Shell Scripts
9. init.rc Commands and Services
10. C Libraries
11. Java Libraries
12. SDK add-ons

# 1. Programming Languages

- Java:
  - Apps
  - Platform
- C:
  - Apps
  - Platform
- JavaScript / CSS / HTML
  - WebKit object
- C#:
  - Mono for Android
- Misc.
  - Any language for which there's a Linux compiler / interpreter

# 2. Standard App Mechanisms

- Components:
  - Activity
  - Service
  - Content Provider
  - Broadcast Receiver
- “Application” Component
- Widgets

# 2.1. “Application” Component

- See packages/apps/Phone:
  - Especially src/com/android/phone/PhoneApp.java

```
/**
 * Top-level Application class for the Phone app.
 */
public class PhoneApp extends Application {
    PhoneGlobals mPhoneGlobals;

    public PhoneApp() {
    }

    @Override
    public void onCreate() {
        if (UserHandle.myUserId() == 0) {
            // We are running as the primary user, so should bring up the
            // global phone state.
            mPhoneGlobals = new PhoneGlobals(this);
            mPhoneGlobals.onCreate();
        }
    }
}
...

```

## 2.2. Widgets

- See:

<https://developer.android.com/guide/topics/appwidgets>

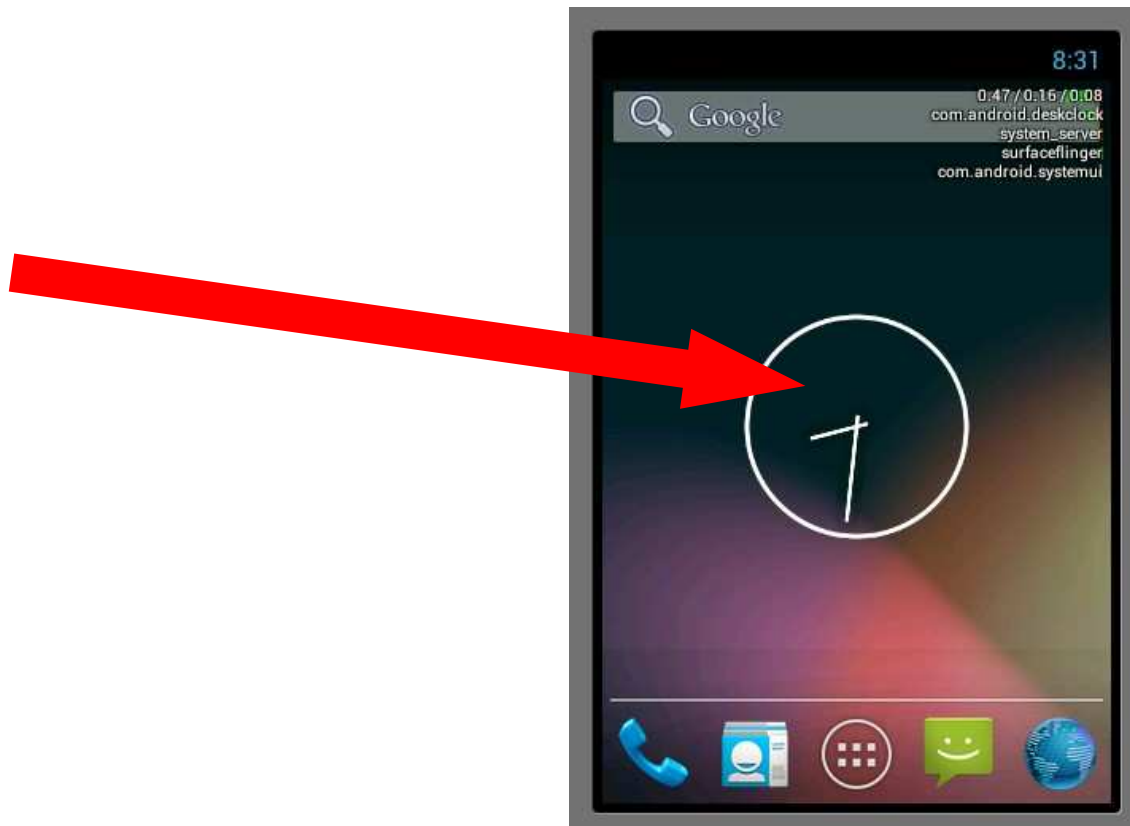

# 3. Special App Mechanisms

- Foreground services
- Persistent apps
- Sync adapters
- Backup agents
- Input methods engines
- Alarm services
- Live wallpapers
- Account managers
- Device administrators
- “Core” app

# 3.1. Foreground services

- Sticky notification icon
- Ex:
  - Skype
  - Avast
- See:
  - <https://developer.android.com/guide/components/services.html#Foreground>
  - <https://developer.android.com/reference/android/app/Service.html#startForeground%28int,%20android.app.Notification%29>
  - [https://developer.android.com/reference/android/app/Notification.html#FLAG\\_FOREGROUND\\_SERVICE](https://developer.android.com/reference/android/app/Notification.html#FLAG_FOREGROUND_SERVICE)

## 3.2. Persistent apps

- Flag in <application> decl. in manifest:  
    `android:persistent="true"`
- For “system” apps only
- Will cause app to be kept alive by ActivityManager
- IOW:
  - It'll be automagically restarted if it dies
  - Lifecycle won't result in it dying

## 3.3. Sync adapters

- For sync'ing with a cloud service
- Typically for REST-based apps
- Ex.: a Twitter-like feed
- See:
  - <http://www.google.com/events/io/2010/sessions/developing-RESTful-android-apps.html>

## 3.4. Backup Agents

- Triggered by Backup Manager
- See:
  - <https://developer.android.com/guide/topics/data/backup.html>

# 3.5. Input methods Engines

- Virtual on-screen keyboards
- See:
  - <https://developer.android.com/guide/topics/text/creating-input-method.html>

## 3.6. Alarm services

- Cause Intent to trigger in the future:
- See:
  - <https://developer.android.com/reference/android/app/AlarmManager.html>

## 3.7. Live wallpapers

- Animated wallpapers
- See:
  - <http://www.vogella.com/articles/AndroidLiveWallpaper/article.html>

## 3.8. Account managers

- For managing accounts in Settings
- See:
  - <https://developer.android.com/reference/android/accounts/AccountManager.html>

# 3.9. Device administrators

- Enterprisification feature:
- See:
  - <https://developer.android.com/guide/topics/admin/device-admin.html>

## 3.10. “core” app

- Use this tag in <manifest> tag:  
    `coreApp="true"`
- Used by:
  - StatusBar
  - SettingsProvider
  - See `frameworks/base/packages/`
- See “onlyCore” variable in `SystemService.java`
- Causes only core apps to start if set to “true”
- Default hard-coded as “false”
- `PackageManagerService.java` has detail of how it's used

# 4. Starting Apps

- Intents
- Content Resolvers

# 5. Native Utilities and Daemons

- Compile as part of AOSP:  
    `BUILD_EXECUTABLE`
- Build outside AOSP and merge:
  - Link statically (like `adbd`), or
  - Link dynamically (against Bionic or `glibc` or ...)
- Run like any regular Linux command-line tool
- Start from:
  - `adb shell`
  - `init.rc`
  - shell script
  - Android app (N.B. This will continue running independently)
- Plenty of existing examples: `netd`, `vold`, `installd`, etc.

# 5.1. Start from Android app

```
Process myUtil;  
BufferedReader myCliOutput;  
  
myUtil =  
    Runtime.getRuntime().exec("my_cli_util -P params");  
  
myCliOutput =  
    new BufferedReader(  
        new InputStreamReader(  
            myUtil.getInputStream()));
```

# 6. Java Utilities (and Daemons)

- Coded as a “library”
- Launched using `app_process` utility
- Use script to wrap call to `app_process`
- See `frameworks/base/cmds` for examples:
  - `am`
  - `pm`
  - `svc`
  - ...
- No known case of “daemon”, but should be feasible
  - Closest is System Server, but it's started from Zygote, not directly from `app_process`

# 7. System Services

- Start in:
  - Existing Java system services
  - App (like Phone or NFC)
  - C daemon (like Media Service or SurfaceFlinger)
- Register with Service Manager
- Provide API speak with system service:
  - In existing framework
  - As SDK add-on

# 8. Shell Scripts

- Android has built-in shell
- Since 4.0, MirBSD Korn Shell
- See: <https://www.mirbsd.org>
- Start shell script like any other native utility
- For example, `init.goldfish.rc` does:

```
service goldfish-setup /system/etc/init.goldfish.sh
    user root
    group root
    oneshot
```

# 9. init.rc Commands and Services

- Edit relevant init.\*.rc to:
  - Add commands to existing actions
  - Create new actions based on global property triggers
  - Add new services
- See:
  - system/core/root/init.rc
  - device/[vendor]/[product]/init.\*.rc

# 10. C Libraries

- Build libs as part of AOSP or using NDK:  
`BUILD_SHARED_LIBRARY`
- Use library in native utility or daemon:  
`LOCAL_SHARED_LIBRARIES := libfoo ...`
- Provide headers files as needed
- Can load library explicitly in Java, espc. for JNI
- See “HelloJNI” example in NDK for NDK ex.

```

public class HelloJni extends Activity
{
    /** Called when the activity is first created. */
    @Override
    public void onCreate(Bundle savedInstanceState)
    {
        super.onCreate(savedInstanceState);

        /* Create a TextView and set its content.
         * the text is retrieved by calling a native
         * function.
         */
        TextView tv = new TextView(this);
        tv.setText( stringFromJNI() + " " + pid() );
        setContentView(tv);
    }

    /* A native method that is implemented by the
     * 'hello-jni' native library, which is packaged
     * with this application.
     */
    public native String  stringFromJNI();
...
    /* this is used to load the 'hello-jni' library on application
     * startup. The library has already been unpacked into
     * /data/data/com.example.HelloJni/lib/libhello-jni.so at
     * installation time by the package manager.
     */
    static {
        System.loadLibrary("hello-jni");
    }
}

```

# 11. Java Libraries

- Build as part of AOSP:  
    BUILD\_JAVA\_LIBRARY
- Or create using Eclipse
- Will generate a .jar
- See:
  - <http://www.vogella.com/articles/AndroidLibraryProjects/article.html>
  - <http://stackoverflow.com/questions/3642928/adding-a-library-jar-to-an-eclipse-android-project>

# 12. SDK add-ons

- See device/sample/, esp.:
  - README
  - products/sample\_addon.mk
  - sdk\_addon/
  - frameworks/PlatformLibrary/
- Creates a ZIP file
- Extract in [sdk-dir]/add-ons/

# Hacks, Variants, Tricks, and Resources

- 1.AOSP's limitations
- 2.Tearing AOSP apart
- 3.Forks
- 4.Ports
- 5.Mods
- 6.Melds
- 7.Headless Android

# 1. AOSP's limits

- Rigid
- Closed dev model
- Fits Google's prerogatives
- Excludes a lot of stuff
- ... IOW, doesn't always fit what you need

## 2. Tearing AOSP apart

- Forks
- Ports
- Mods
- Melds

# 3. Forks

- Cyanogenmod
- Replicant
- MIUI

# 3.1. Cyanogenmod

- After-market handset firmware
- Requires rooted phone
- <http://www.cyanogenmod.com>
- Advertized features:
  - Lockscreen Gestures
  - Phone Goggles
  - OpenVPN
  - Incognito mode
  - Themes support
  - DSP Equalizer



# What is CyanogenMod?

CyanogenMod is an aftermarket firmware for a number of cell phones based on the open-source Android operating system. It offers features not found in the official Android based firmwares of vendors of these cell phones.



A customized aftermarket firmware distribution

- More interestingly:
  - <http://wiki.cyanogenmod.com/>
  - <https://github.com/CyanogenMod>
  - Includes Busybox
  - Custom Launcher (ADWLauncher)
  - Lots of tiny tweaks and mods ... worth doing a “diff”

## 3.2. Replicant

- Android distro that is 100% Free Software
- <http://replicant.us/>
- Includes FDroid free software app store



The screenshot shows a web browser window displaying the homepage of the Replicant project. The browser's address bar shows the URL <http://replicant.us/>. The page features a large red Android robot icon on the left and the word "Replicant" in a large, black, serif font on the right. Below the main content, there is a navigation menu with links for Home, About, Applications, Contact, Devices, Download, FAQ, How to help, and Wiki and Trac. A news section titled "Replicant 2.2 preview 008 is out!" is visible, with a sub-header "Posted on June 23, 2011 by admin". A search bar and an "Archives" section with a link for "June 2011" are also present.

## 3.3. MIUI

- Closed-source fork with slick UI enhancements
- Many translations
- <http://en.miui.com/>
- Advertized features:
  - Home screen
  - Dialer
  - SMS
  - Contacts
  - Themes
  - Camera
  - Gallery
  - Net disk, File manager, Traffic monitor, Backup, Notes, ...



# What is MIUI?

MIUI is one of the most popular Android ROMs in the world. It is based on Android 2.3, featuring better experience and richer themes. MIUI is updated every Friday based on the feedback from its test users.



# 4. Ports

- RIM Playbook
- BlueStacks
- Alien Dalvik

# 4.1. RIM Playbook

The screenshot shows a web browser window displaying the BlackBerry PlayBook product page. The browser's address bar shows the URL <http://us.blackberry.com/playbook-tablet/>. The page features the BlackBerry logo and navigation links for Smartphones, Tablets, Apps & Software, Support, Business, Where to Buy, and Communities. A search bar is located in the top right. The main content area includes the heading "BlackBerry PlayBook." and a blue button labeled "Where to Buy". Below this, the text reads "Get to know the BlackBerry PlayBook" and "The world's first professional-grade tablet." with an "Explore now" link. A large image of the BlackBerry PlayBook tablet is shown, displaying its home screen with various app icons and a central content area. The browser's status bar at the bottom indicates "Scripts Partially Allowed, 6/7 (facebook.com, atdmt.com, blackberry.com, 2o7.net, invitemedi.com, doubleclick.net) | <SCRIPT>: 55 | <OBJECT>: 0" and "Transferring data from us.blackberry.com...".

# 4.2. BlueStacks

The image shows a browser window displaying the BlueStacks website. The browser's address bar shows the URL <http://www.bluestacks.com/>. The website header features the BlueStacks logo, which includes a green Android robot icon, and the text "BlueStacks Android Player for Windows". Below the logo is a green button that says "SIGN UP HERE TO BE AN ALPHA TESTER". The main content area features a large graphic of a hand pointing at a virtual desktop environment. This desktop is split into two parts: one showing an Android desktop with various app icons and a large green Android robot, and the other showing a Windows desktop with the classic four-pane logo. Text at the bottom of this graphic reads "Switch instantly between Android and". To the right of the graphic, the text says "All your favorite **Android apps** now on **Windows PC**". Below this is a large green play button icon with the text "Play Video". At the bottom right, there is a social media-style notification from "bluestacksinc" dated "One day ago" with the text "LG Wants To Open Up A Development Lab In Silicon Valley <http://ow.ly/1uLiT0> via @thedroidguy". The browser's status bar at the bottom left shows the word "Done".

# 4.3. Alien Dalvik (Myriad Group)



Figure 2 : Alien Dalvik running Android Photoshop on Nokia N900 vs native application on HTC legend

Myriad Alien Dalvik runs the Photoshop Android application on a Nokia N900. The application shows exactly as the original application running on an HTC legend. While the mobile handsets are very similar - both using 600MHz ARM processors, performance appear the same or better on the Nokia thanks to the use of Myriad Dalvik Turbo technology.

## Myriad Alien Dalvik on MeeGo

Myriad Alien Dalvik will be first commercially available on the MeeGo platform. A very tight integration to both the Android SDK and the MeeGo SDK (QTCreator) makes it very easy to modify, package and test applications.

Most Android applications can run unmodified as the vast majority of Android APIs are supported and tight integration with the QT framework leads to a seamless user experience.

Ported applications demonstrate no loss of performance compared to the Android applications running in the native environment, thanks to Myriad Dalvik Turbo technology. As an example, when running on the Nokia N900, Myriad Alien Dalvik demonstrates similar or superior performances.

First implemented on the MeeGo/Maemo platform, Myriad Alien Dalvik can support other platforms, to be developed depending on customers needs.

# 5. Mods

- XDA Developers
- ...

# 6. Melds

- Stock glibc stack (as covered earlier)

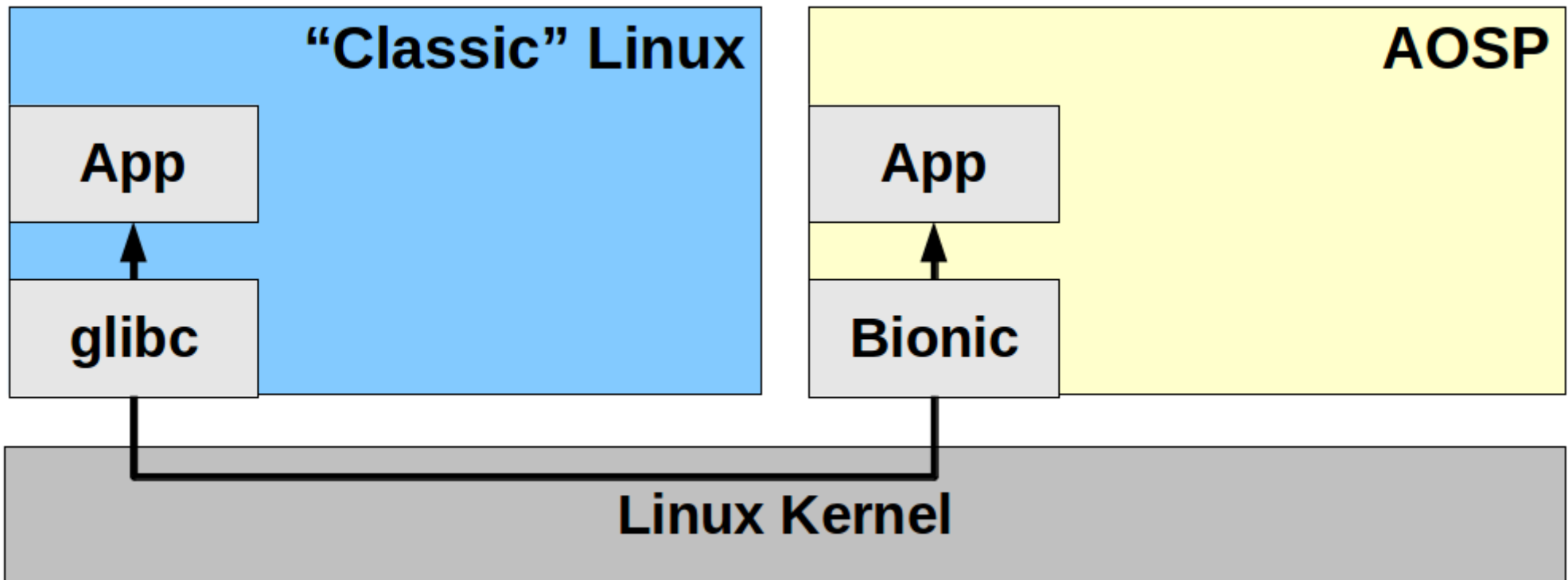

- Custom stacks

# 7. Headless Android

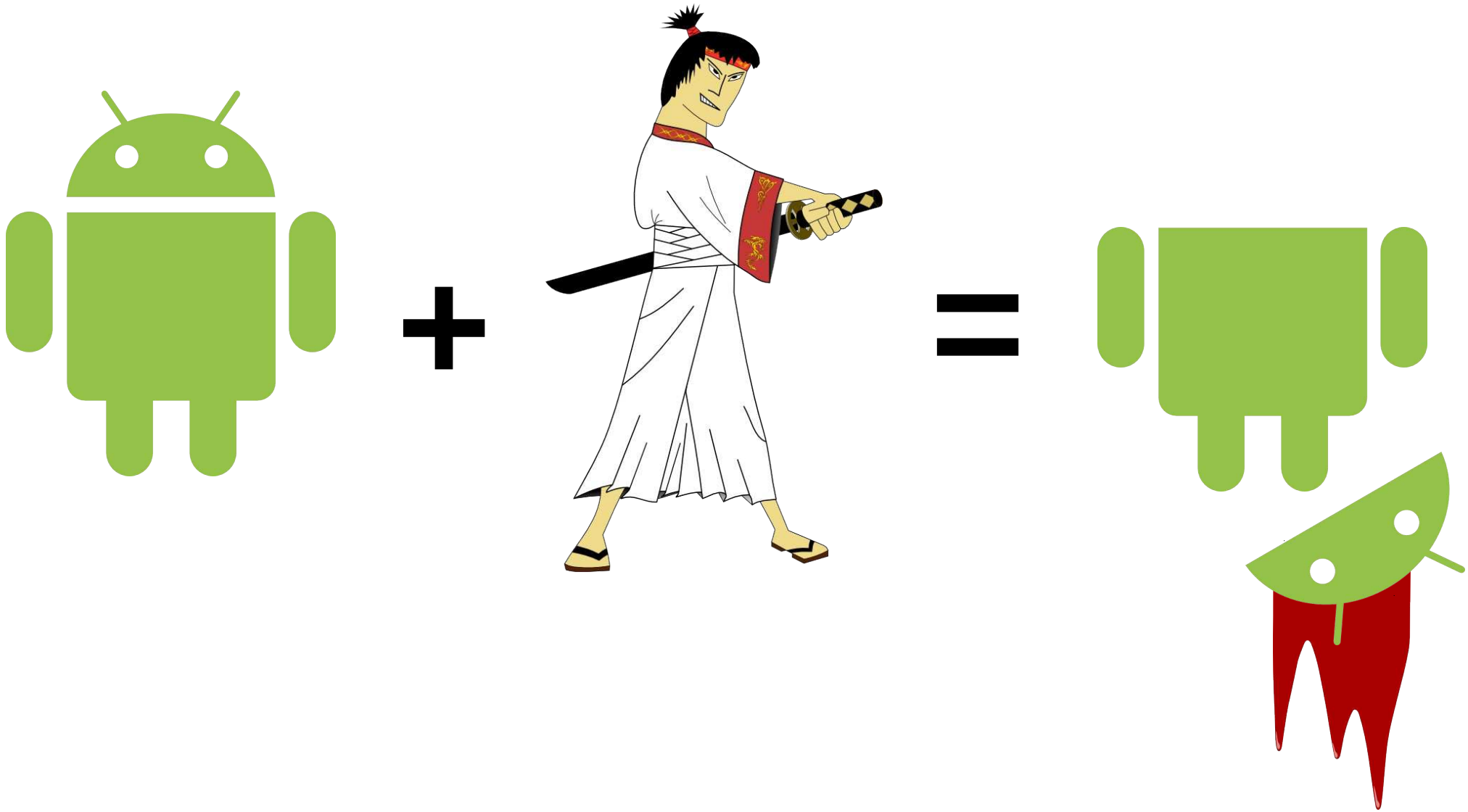

“And then GNU came back for revenge ...” -- Tarantino's sequel

# 7.1. Why?

- Took me a long time to wrap my *head* around
  - “Why don't you just use embedded Linux?”
- What's “Embedded Linux” anyway?
- NEW: Nexus Q

## 7.2. Possibilities

- No Java:
  - TinyAndroid:

```
$ BUILD_TINY_ANDROID=true make -j4
```
  - AOSP w/ custom products .mk file
- The full-blown stack **without**:
  - SurfaceFlinger
  - WindowManager
  - WallpaperService
  - InputMethodManager

## 7.3. Tiny Android

- 3MB filesystem
- Minimal root fs
- init
- toolbox + shell
- adb
- bionic + utility libs
- No “system/framework/”
- No “system/app”

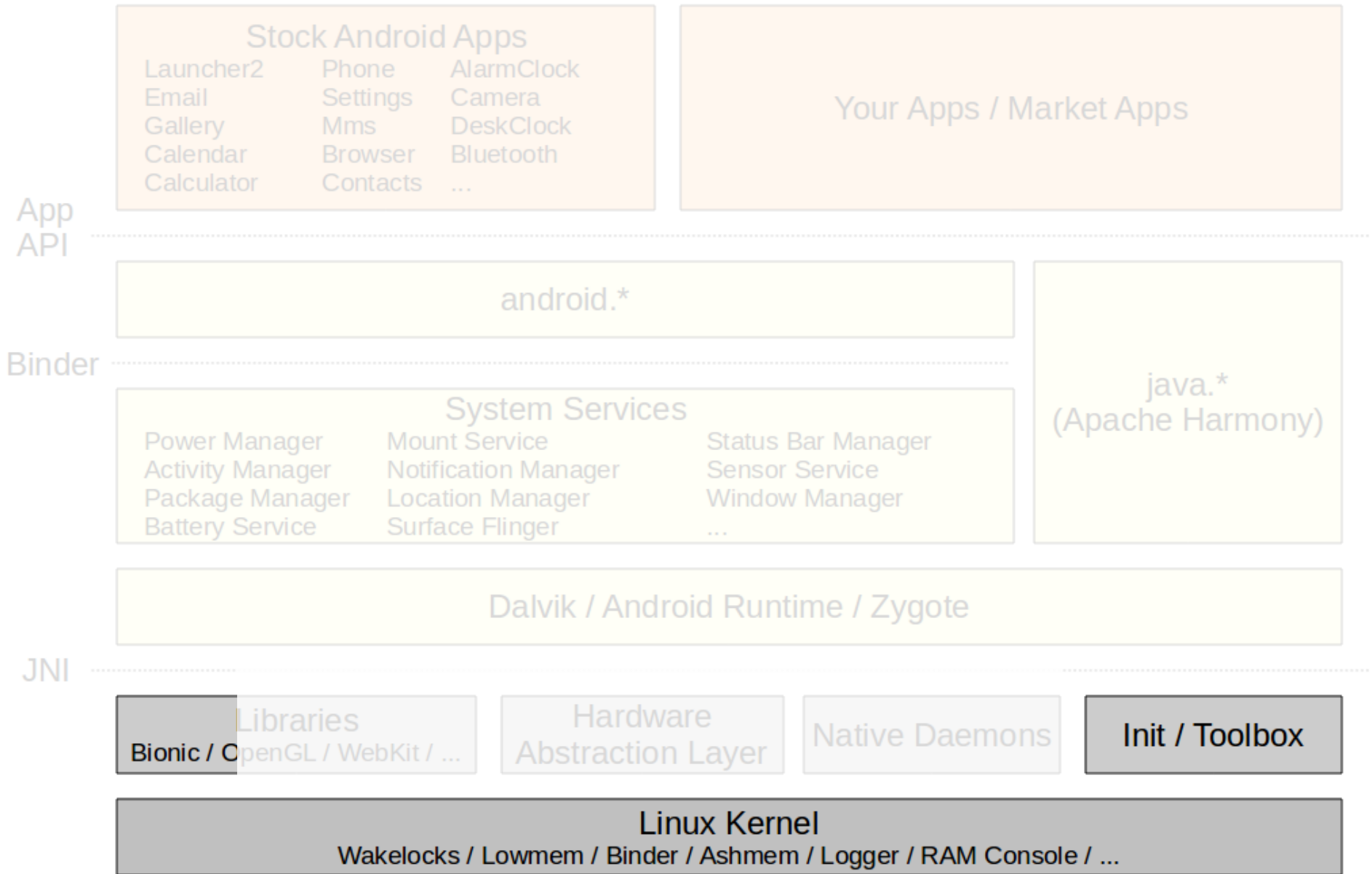

# 7.4. AOSP w/ custom product .mk

- Have a look at:
  - build/target/product/\*.mk
- Create your own device under “/device” and have fun
- Disable zygote at startup
- Remove all apks
- ...

# 7.5. Full stack

- Disable:
  - SurfaceFlinger
  - WindowManager
  - WallpaperService
  - InputMethodManager
  - SystemUI
- Don't let SurfaceFlinger Client try to open binder to SurfaceFlinger
- Feed bogus values back from SurfaceFlinger Client
- Disable qemud (emulator artefact)
- Tweak internals by disabling key calls:
  - In ActivityStack.java:
    - startHomeActivityLocked()
    - setAppStartingWindow()
  - wm.detectSafeMode()
  - wm.systemReady()
  - wm.reclaimSurfaceMemoryLocked()

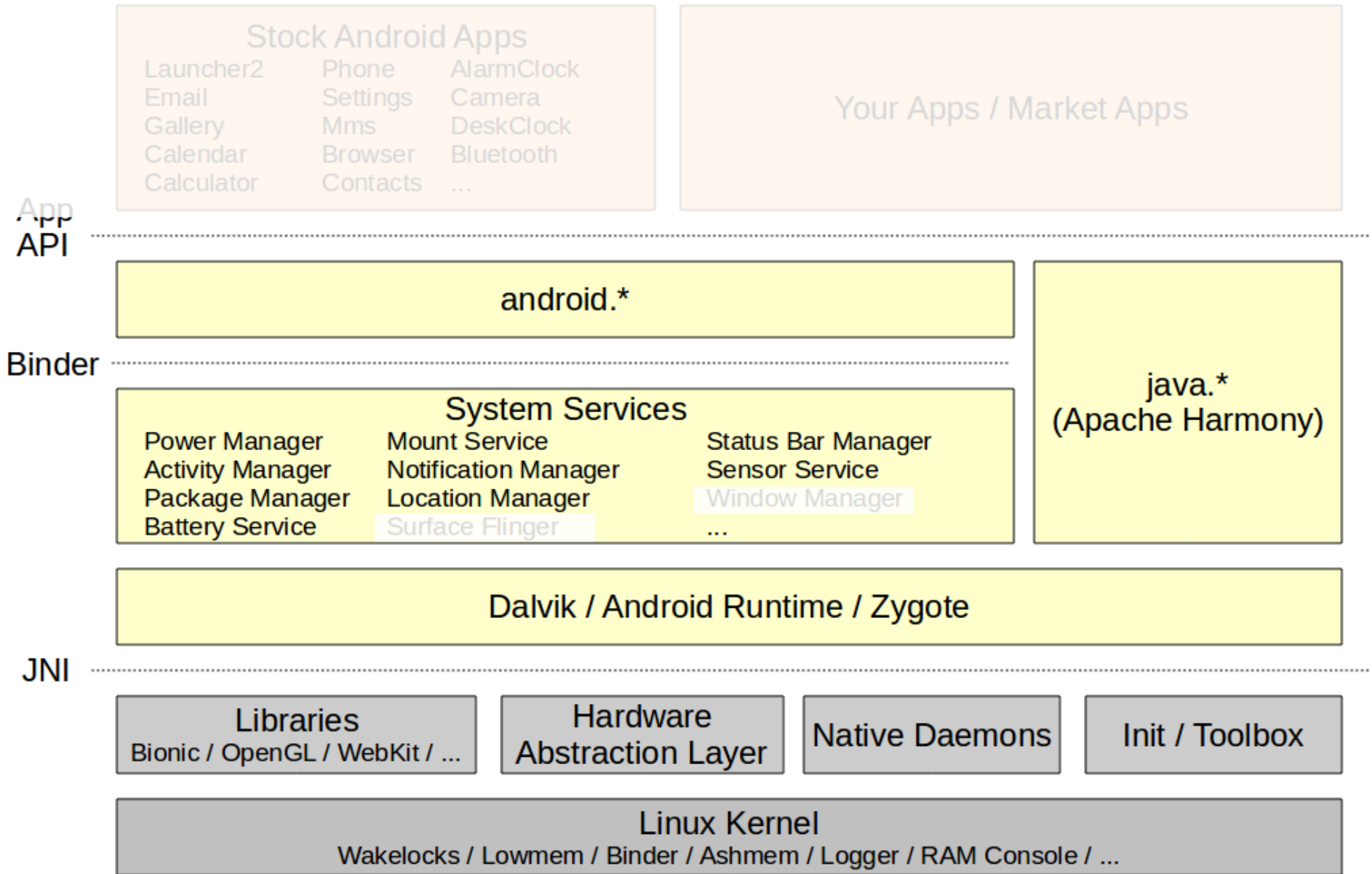

# Manipulating storage devices

- 1.MTD subsystem concepts
- 2.MTD usage basics
- 3.Native CFI flash
- 4.Disk devices
- 5.Swapping

# 1. MTD subsystem concepts

- MTD support for solid-state storage devices: flash, DOC, ROM, RAM, etc.
- 3 layers:
  - MTD chip drivers
  - MTD “glue logic”
  - MTD “user modules”
- Main MTD project URL:  
<http://www.linux-mtd.infradead.org>

- Chip drivers:
  - NAND
  - OneNAND
  - CFI
  - NOR
  - RAM, ROM, and absent chips
  - Uncached RAM
  - Virtual devices for testing and evaluation
  - DiskOnChip (bit rot)

- “Mapping drivers” allow the MTD subsystem to locate and access the actual chips.
- When your chip is supported, you need to write the mapping driver for your board.
- MTD can manage multiple instances of a chip
- MTD can partition and concatenate devices
- User-modules provide additional functionality which allow chips to be accessed through the kernel's virtual filesystem layer.

- User-modules:
  - UBIFS:
    - Works on top of UBI (Unsorted Block Images), on top of MTD
    - UBI provides wear-leveling
    - Scalability
    - Fast mount, fast I/O, on-the-flight compression
    - Provides power-down reliability
  - YAFFS2
    - NAND flash
    - Includes wear-leveling
    - No compression
    - Provides power-down reliability (no fsck)

- JFFS2 (Journalling Flash File System version 2):
  - Implements log-structured FS on device
  - FS recreated in RAM at mount time
  - Includes wear-leveling
  - Implements data compression
  - Provides power-down reliability (no fsck)
- NFTL (NAND Flash Translation Layer) and INFTL (Inverse NFTL) for M-Systems DiskOnChip devices
- FTL (Flash Translation Layer), part of PCMCIA std.

- Char device:
  - Provides direct access to chip as a char device
  - Very useful for programming device in Linux
- Caching block device:
  - Provides a simple block device interface to MTD devices
  - Can mount a block FS straight on it for reading & writing
  - Does NOT provide power-down reliability
  - Does NOT implement smart device management
- Read-only block device:
  - Same as caching block device, but read-only

## 2. MTD usage basics

- MTD subsystem developed independently from kernel.
- Recommended to use latest kernel
- Bleeding edge is in MTD git repo
- MTD subsystem requires /dev entries that differ from devices.txt file specification.
- MTD /dev entries are as listed in BELS table 7.1 and 7.2.

- Types of MTD /dev entries:
  - mtdN => each instance is separate MTD device or partition.
  - mtdrN => each instance is read-only copy of mtdN entry.
  - mtdblockN => each instance is block device copy of mtdN.
  - nftlN => each instance is separate NFTL device. Further numbered like hd.
  - ftlN => similar naming as nftlN
- If MTD devices are accessible on host, can use the packaged device creation script.

- Main MTD kernel configuration options:
  - Memory Technology Device (MTD) support:  
Must be set to use MTD subsystem
  - MTD partitioning/concatenating support:  
Enables partitioning/concatenating MTD devices
  - Direct char device access to MTD devices:  
Required for accessing MTD devices as char devices
  - Caching block device access to MTD devices:  
Enables mounting MTD device as normal rw block device
  - Read-only block device access to MTD devices:  
Same as above, but read-only
  - FTL (Flash Translation Layer)  
Provides FTL MTD user module
  - NFTL (NAND Flash Translation Layer)  
Provides NFTL MTD user module

- INFTL (Inverse NAND Flash Translation Layer)  
Provides INFTL MTD user module
- Can only set mtdblock or mtdblock\_ro as built-in.  
Can set both as modules.
- Support for JFFS2 and JFFS is found in the “File Systems” submenu.
- MTD Submenus:
  - RAM/ROM/Flash chip drivers:  
Support for CFI, JEDEC, non-CFI, RAM, ROM, etc.
  - Mapping drivers for chip access  
Default mapping drivers for quite a few boards
  - Self-contained MTD device drivers  
Uncached RAM, VM test drv, blk dev emu, DOC devices

- NAND Flash Device Drivers
  - NAND flash
- During development:
  - Build MTD options as modules
- For production:
  - Select MTD options as built-in
- MTD utilities:
  - MTD subsystem requires special tools (can't use conventional disk utilities.)
  - MTD utilities are very powerful. Be careful when using them, you could destroy your device.

- Generic tools:

- flash\_info => get erase information
- flash\_erase => erase device
- flash\_eraseall => erase entire device
- flash\_unlock => unlock flash protection
- flash\_lock => lock flash protection
- flashcp => copy file to flash
- doc\_loadbios => copy bootloader to device
- mtd\_debug => access MTD debugging

- Filesystem creation tools:
  - mkfs.jffs2 => create JFFS2 filesystem image
  - mkfs.jffs => create JFFS filesystem image
  - jffs2dump => dumps the content of a JFFS2 image (can't mount JFFS2 on loopback.)
- NFTL tools:
  - nftl\_format => write NFTL format on device
  - nftldump => dump NFTL content to file
- FTL tools:
  - ftl\_format => write FTL format on device
  - ftl\_check => verify FTL format

- NAND chip tools
  - nandwrite => write to NAND device
  - nandtest => test NAND device
  - nandump => dump NAND device content
- Installing MTD tools on host:
  - Get and put in `${PRJROOT}/build-tools`:
    - Zlib: <http://www.zlib.net>
    - LZO: <http://www.oberhumer.com/opensource/lzo/>
    - Libacl: <http://oss.sgi.com/projects/xfs/>
    - MTD: <git://git.infradead.org/mtd-utils>
  - Make sure you have LZO And UUID installed:

```
$ sudo apt-get install liblzo2-dev
$ sudo apt-get install uuid-dev
```

- Installing MTD tools for target:
  - Configure and compile zlib:

```
$ cd ${PRJROOT}/build-tools/  
$ tar xvzf zlib-1.2.5.tar.gz  
$ cd zlib-1.2.5  
$ CC=${TARGET}-gcc \  
> LDSHARED="${TARGET}-ld -shared" \  
> ./configure --shared  
$ make  
$ make prefix=${TARGET_PREFIX} install
```

- Configure and compile lzo:

```
$ cd ${PRJROOT}/build-tools/  
$ tar xvzf lzo-2.03.tar.gz  
$ cd lzo-2.03  
$ CC=powerpc-unknown-linux-gnu-gcc ./configure \  
> --enable-shared --host=i686-linux \  
> --target=powerpc-unknown-linux-gnu  
$ make  
$ make prefix=${TARGET_PREFIX} install
```

- Got to `${PRJROOT}/build-tools`

- Extract git snapshot:

```
$ git clone git://git.infradead.org/mtd-utils
```

- Copy the `acl.h` header:

```
$ cd ${PRJROOT}/build-tools
$ tar xvzf acl_2.2.47-1.tar.gz
$ mkdir ${PRJROOT}/mtd-utils/include/sys
$ acl-2.2.47/include/acl.h \
> ${PRJROOT}/mtd-utils/include/sys
```

- Go to `mtd-utils/` and build tools:

```
$ make
```

- Install tools:

```
$ make DESTDIR=${PREFIX} SBINDIR="" install
```

# 3. Native CFI flash

- Relatively straight-forward
- Kernel configuration:
  - Memory Technology Device (MTD) support
  - MTD partitioning/contactenating support, if needed
  - Direct char access to MTD devices
  - Caching block device access to MTD devices
  - “RAM/ROM/...” submenu: Detect flash chip by Common Flash Interface (CFI) and Support for Intel/Sharp and AMD/Fujitsu flash chips.
  - “Mapping drivers ...” submenu: select CFI mapping for board

- Partitioning can be done in mapping driver
- Newer partitioning method using boot param:

```
mtddparts=0:256k(ppcboot)ro,768k(kernel),1m(user),-(initrd);
    1:2m(cramfs),-(jffs2)
```

- For TQM860L, partition is as follows:

TQM flash bank 0: Using static image partition definition

Creating 4 MTD partitions on "TQM8xxL Bank 0":

```
0x00000000-0x00040000 : "ppcboot"
```

```
0x00040000-0x00100000 : "kernel"
```

```
0x00100000-0x00200000 : "user"
```

```
0x00200000-0x00400000 : "initrd"
```

TQM flash bank 1: Using static file system partition definition

Creating 2 MTD partitions on "TQM8xxL Bank 1":

```
0x00000000-0x00200000 : "cramfs"
```

```
0x00200000-0x00400000 : "jffs2"
```

- Partitions are on erase block boundaries (128KB)

- Creation of necessary /dev entries:

```
$ cd ${PRJROOT}/rootfs/dev
```

```
$ su -m
```

```
Password:
```

```
# for i in $(seq 0 5)
```

```
> do
```

```
> mknod mtd$i c 90 $(expr $i + $i)
```

```
> mknod mtblock$i b 31 $i
```

```
> done
```

```
# exit
```

```
$ ls -al mtd*
```

```
crw-rw-r-- 1 root root 90, 0 Jun 25 17:19 mtd0
```

```
crw-rw-r-- 1 root root 90, 2 Jun 25 17:20 mtd1
```

```
crw-rw-r-- 1 root root 90, 4 Jun 25 17:20 mtd2
```

```
crw-rw-r-- 1 root root 90, 6 Jun 25 17:20 mtd3
```

```
crw-rw-r-- 1 root root 90, 8 Jun 25 17:20 mtd4
```

```
crw-rw-r-- 1 root root 90,10 Jun 25 17:20 mtd5
```

```
brw-rw-r-- 1 root root 31, 0 Jun 25 17:17 mtblock0
```

```
brw-rw-r-- 1 root root 31, 1 Jun 25 17:17 mtblock1
```

```
brw-rw-r-- 1 root root 31, 2 Jun 25 17:17 mtblock2
```

```
...
```

- Must erase flash before writing:

```
# flash_eraseall /dev/mtd3
```

```
Erased 2048 Kibyte @ 0 -- 100% complete.
```

- Writing:

```
# cat /tmp/initrd.bin > /dev/mtd3
```

- Reading:

```
# dd if=/dev/mtd0 of=/tmp/u-boot.img
```

# 4. Disk devices

- There is a lot of documentation on how to manipulate disk devices in Linux.
- Main tool: `fdisk`

```
# fdisk
```

```
Command (m for help): m
```

```
Command action
```

```
  a  toggle a bootable flag
  b  edit bsd disklabel
  c  toggle the dos compatibility flag
  d  delete a partition
  l  list known partition types
  m  print this menu
  n  add a new partition
  o  create a new empty DOS partition table
  p  print the partition table
  q  quit without saving changes
  s  create a new empty Sun disklabel
  t  change a partition's system id
  u  change display/entry units
  v  verify the partition table
  w  write table to disk and exit
  x  extra functionality (experts only)
```

- Once partitions are created, use the `mkfs` utility described earlier to create a filesystem type on the device and use `mount` to mount new filesystem.
- If need be, use LILO as described earlier to install bootloader on secondary hard-disk.

# 5. Swapping

- Discouraged for all types of embedded Linux systems, except large ones.
- Strongly discourage for any system relying on solid-state storage.
- Use `swapon` to enable swapping on a device and `swaponoff` to disable swapping on a device.

# Choosing and installing the rootfs

1. Selecting a filesystem
2. Writing images to flash using NFS
3. CRAMFS
4. ROMFS
5. Squashfs
6. UBIFS
7. JFFS2
8. Disk filesystem over RAM disk
9. Comparing filesystem image size
10. TMPFS
11. Live updates

# 1. Selecting a filesystem

- Important part of system design
- Requires understanding of filesystem capabilities and system's dynamics.
- Filesystem characteristics:
  - Write
  - Persistent
  - Power down reliability
  - Compression
  - Lives in RAM

- Selecting a filesystem:
  - RAM disk:
    - Large amount of RAM
    - Limited amount of flash
    - Don't need to keep changes across reboots
    - For persistence, use with additional filesystem
    - Easiest way to get self-hosting target
    - Replaced by initramfs
  - CRAMFS
    - Compressed ROM filesystem
    - Requires less RAM than a RAM disk
    - Cannot be written to (read-only)

- Maximum file-size of 16 MB
- No current or parent directories
- 16-bit UID / 8-bit GID
- All timestamps set to Epoch
- All files have link count of 1
- Requires block device
- ROMFS
  - ... read-only
  - Requires block device
  - Stores the bare-minimum details required for a filesystem
  - Does not store: dates, permissions
  - Used to be used by uClinux since no protection anyway
  - No compression

- Squashfs:
  - Compressed ROM filesystem, better than CRAMFS
  - Requires block device
- UBIFS:
  - JFFS2-replacement
  - All benefits of JFFS2 w/ better performance and scalability
  - Benefits most apparent on large images
- JFFS2
  - Compressed
  - Read / write
  - Perfect for devices that need field-updating
  - Power-down reliability (no roll-back)
  - Wear-leveling

- Using a regular disk device:
  - Have a look at the slew of disk filesystems supported by Linux. BELS contains a few pointers if you're out of inspiration.

## 2. Writing images to flash using NFS

- May not have access to flash device from host, but may need to put image generated on host in target flash.
- Steps:
  1. Generate image on host
  2. Cross-build MTD utilities for target and install in  $\{PRJROOT\}/rootfs$
  3. Mount target's rootfs using NFS
  4. On host, copy image to directory mounted by target as rootfs.
  5. Use MTD utilities to copy image from rootfs to appropriate `/dev` entry.

# 3. CRAMFS

- Latest available from:  
<http://sourceforge.net/projects/cramfs/>
- Download CRAMFS (1.1) utilities into your `$ {PRJROOT}/build-tools` directory and uncompress there.
- Build and install CRAMFS utilities:

```
$ cd ${PRJROOT}/build-tools/cramfs-1.1  
$ make  
$ cp cramfsck mkcramfs ${PREFIX}/bin/
```

- Creating a rootfs image:

```
$ cd ${PRJROOT}
$ mkcramfs rootfs/ images/cramfs.img
Directory data: 3960 bytes
Everything: 3452 kilobytes
Super block: 76 bytes
CRC: f74fb18c
warning: gids truncated to 8 bits (this may be a security concern)
```

- Example filesystem image writing to device, if MTD device accessible on host:

```
$ su -m
Password:
# cat images/cramfs.img > /dev/mtd5
# exit
```

- Use NFS-writing if device not accessible from host

# 4. ROMFS

- Latest available from: <http://romfs.sourceforge.net/>
- Download genromfs (0.5.2) utilities into your `$(PRJROOT)/build-tools` directory and uncompress there.
- Build and install genromfs utilities:

```
$ cd $(PRJROOT)/build-tools/genromfs-0.5.2
$ make
$ cp genromfs ${PREFIX}/bin
```
- Creating a ROMFS image:

```
$ cd $(PRJROOT)
$ su -m
# genromfs -d rootfs/ -f images/romfs.img
# chown karim:karim images/romfs.img
```

# 5. Squashfs

- Latest available from: <http://www.squashfs.org>
- Download squashfs (4.1) into your `$(PRJROOT)/build-tools` directory and uncompress there.
- Make sure you have `libacl1-dev` installed:  

```
$ sudo apt-get install libacl1-dev
```
- Build and install `genromfs` utilities:  

```
$ cd $(PRJROOT)/build-tools/squashfs4.1  
$ make  
$ cp mksquashfs unsquashfs $(PREFIX)/bin
```
- Creating a SquashFS image:  

```
$ cd $(PRJROOT)  
$ mksquashfs rootfs/ images/squashfs.img
```

# 6. UBIFS

- Tools already installed as part of MTD utilities
- Creating a UBIFS image:

```
$ cd ${PRJROOT}
$ mkfs.ubifs -m 512 -e 128KiB -c 100 -x zlib \
> -r rootfs images/ubifs.img
```

# 7. JFFS2

- Tools already installed as part of MTD utilities.
- Creating a JFFS2 image:

```
$ cd ${PRJROOT}
$ mkfs.jffs2 -r rootfs/ -o images/jffs2.img
```
- Can't mount on loopback
- May use `jffs2dump`

# 8. Disk filesystem over RAM disk

- RAM disks behave like block devices
- The RAM disk driver can manage multiple RAM disk instances.
- initrd is mechanism to provide kernel with initial RAM disk for use as rootfs at startup.
- Creating blank filesystem image:

```
$ cd ${PRJROOT}
$ mkdir tmp/initrd
$ dd if=/dev/zero of=images/initrd.img bs=1k count=8192
8192+0 records in
8192+0 records out
8388608 bytes (8.4 MB) copied, 0.0425007 s, 197 MB/s
```

- Formating filesystem image and mounting it:

```
$ su -m
Password:
# /sbin/mke2fs -F -v -m0 images/initrd.img
mke2fs 1.41.12 (17-May-2010)
fs_types for mke2fs.conf resolution: 'ext2', 'small'
Calling BLKDISCARD from 0 to 8388608 failed.
Filesystem label=
OS type: Linux
Block size=1024 (log=0)
Fragment size=1024 (log=0)
Stride=0 blocks, Stripe width=0 blocks
2048 inodes, 8192 blocks
0 blocks (0.00%) reserved for the super user
First data block=1
Maximum filesystem blocks=8388608
1 block group
8192 blocks per group, 8192 fragments per group
2048 inodes per group
...
```

```
# mount -o loop images/initrd.img tmp/initrd
```

- Copying rootfs, umounting, and compressing:

```
# cp -av rootfs/* tmp/initrd
`rootfs/bin' -> `tmp/initrd/bin'
`rootfs/bin/busybox' -> `tmp/initrd/bin/busybox'
`rootfs/bin/ash' -> `tmp/initrd/bin/ash'
`rootfs/bin/cat' -> `tmp/initrd/bin/cat'
`rootfs/bin/chgrp' -> `tmp/initrd/bin/chgrp'
`rootfs/bin/chmod' -> `tmp/initrd/bin/chmod'
...
# umount tmp/initrd
# exit
$ gzip -9 < images/initrd.img > images/initrd.bin
```

- The initrd mechanism is largely favored to be replaced by initramfs.

# 9. Disk filesystem over initramfs

- Initramfs used by kernel at boot time
- Can be linked directly into kernel image
- Creating an initramfs image:

```
$ cd ${PRJROOT}/rootfs  
$ find . | cpio -o -H newc | gzip > ../images/initramfs.img
```

# 10. Comparing filesystem image sizes

- Let's take a look at what we've generate so far:

```
$ cd ${PRJROOT}/images
$ ls -al \
> cramfs.img romfs.img squashfs.img ubifs.img jffs2.img init*
-rw-r--r-- 1 stage stage 3719168 2011-02-25 14:49 cramfs.img
-rw-r--r-- 1 stage stage 3492683 2011-02-25 11:28 initramfs.img
-rw-r--r-- 1 stage stage 8388608 2011-02-25 15:19 initrd.img
-rw-r--r-- 1 stage stage 4237296 2011-02-25 15:13 jffs2.img
-rw-r--r-- 1 stage stage 6949888 2011-02-25 14:50 romfs.img
-rw-r--r-- 1 stage stage 3264512 2011-02-25 14:58 squashfs.img
-rw-r--r-- 1 stage stage 5898240 2011-02-25 15:13 ubifs.img
```

# 11. Mounting directories on TMPFS

- Dynamically resizable RAM-based FS
- Perfect for holding transient data
- No need to create beforehand or format
- Mount:

```
# mount -t tmpfs none /tmp -o size=4m
```

# 12. Live updates

- Only RAM disks can be replaced in its entirety while mounted.
- CRAMFS, ROMFS, Squashfs cannot be replaced
- All rootfses based on other filesystems must be updated while mounted by modifying files and directories one-by-one.
- Four main ways:
  - `rsync`
  - Package management tools
  - `netflash`
  - Ad hoc scripts

- The `rsync` utility:
  - Replaces Unix's `rsh`
  - Allows network update
  - Can be used over SSH
  - Available from: <http://samba.anu.edu.au/rsync/>
  - Need to have daemon running on host and client running in the embedded system.
  - `rsync` most likely already installed by distro.
  - Download (2.5.6) and extract package in your `$ {PRJROOT}/sysapps` directory.

- Configure compile and install `rsync`:

```
$ cd ${PRJROOT}/sysapps/rsync-2.5.6/
$ CC=powerpc-linux-gcc \
> CPPFLAGS="-DHAVE_GETTIMEOFDAY_TZ=1" ./configure \
> --host=$TARGET --prefix=${TARGET_PREFIX}
$ make
$ cp rsync ${PRJROOT}/rootfs/bin
$ powerpc-linux-strip ${PRJROOT}/rootfs/bin/rsync
```

- Use on target:

```
# rsync -e "ssh -l root" -r -l -p -t -D -v \
> --progress \
> 192.168.172.100:/home/karim/example-sys/rootfs/* /
```

- To do a dry run, add “-n” parameter

- Package management tools:
  - dpkg
  - RPM
  - BusyBox dpkg
- The `netflash` utility:
  - Part of uClinux-dist

# Kernel internals

1. Brief history
2. Features
3. General architecture
4. Source layout
5. Process management
6. Filesystems
7. Memory management
8. Communication facilities and interfacing
9. Loadable modules

10. Interrupt and exception management

11. Timing

12. Locking primitives

13. Kernel startup

14. Dealing with kernel failure

# 1. Brief history

- Started on Minix by Linus Torvalds (who wanted to call it Freax ...)
- Rechristened “Linux” by FTP site admin
- Once public, users and contributions grew at a very rapid rate.
- Closed the GNU project's loop
- Most important events:
  - 17 September 1991: Version 0.01
  - 3 December 1991: Version 0.10
  - 8 March 1992: Version 0.95

- 13 December 1992: Version 0.99
- 13 March 1994: Version 1.0
- 7 March 1995: Version 1.2.0
- 9 July 1996: Version 2.0
- 26 January 1999: Version 2.2.0
- 4 January 2001 : Version 2.4.0
- 17 December 2003: Version 2.6.0
- 21 July 2011: Version 3.0.0

## 2. Features

- Portable / Architecture-independent
- Scalable
- Monolithic
- Dynamically extensible (modules)
- Multi-user environment
- Multi-process / Multi-threading
- Memory protection
- Preemptable (starting in 2.5.x) ... but not real-time
- Symmetric multi-processor

- Slew of filesystems
- Slew of networking protocols / NICs
- Quite a few executable formats
- ...

# 3. General architecture

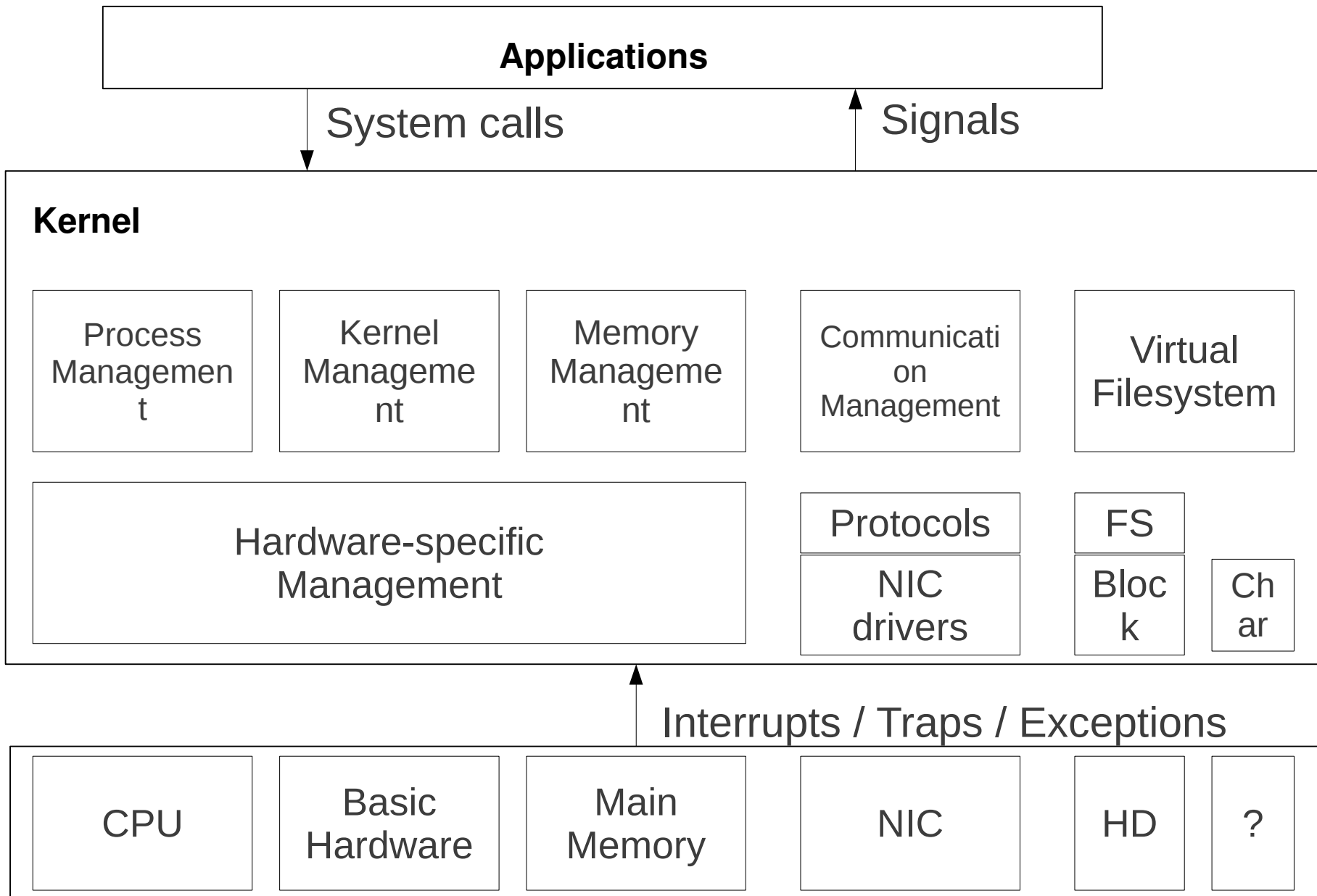

# 4. Source layout

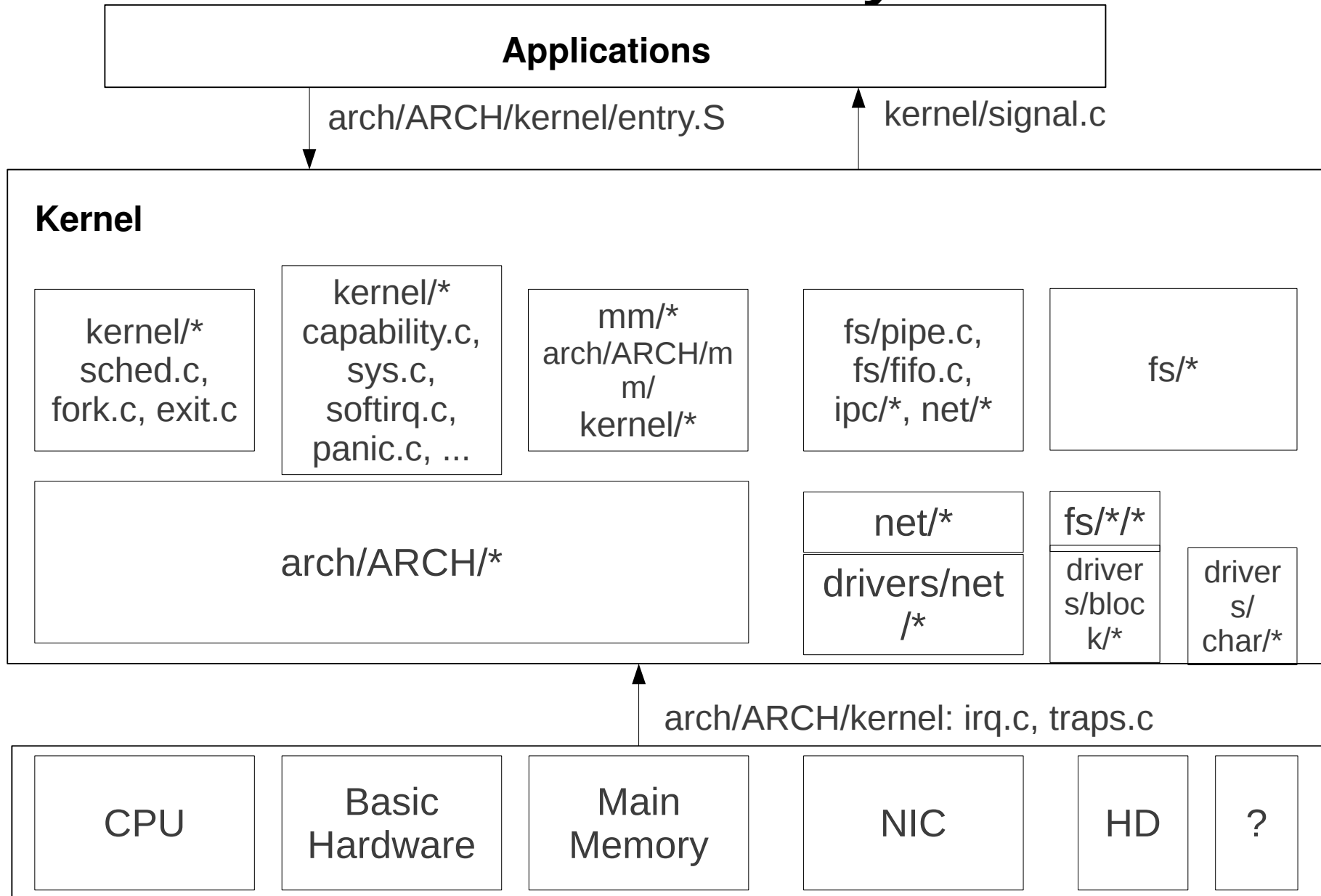

arch	112MB=>	architecture-dependent functionality
block	600KB =>	block layer
Documentation	17MB =>	main kernel documentation
drivers	231MB=>	all drivers
fs	31MB =>	virtual filesystem and all fs types
include	20MB =>	complete kernel headers
init	150KB =>	kernel startup code
ipc	224KB =>	System V IPC
<b>kernel</b>	<b>4.7MB =&gt;</b>	<b>core kernel code</b>
mm	2.2MB =>	memory management
net	20MB =>	networking core and protocols
scripts	1.1MB =>	scripts used to build kernel
tools	2.1MB =>	misc. kernel-related tools

- arch/

2.4M alpha

29M arm

1.4M avr32

5.3M blackfin

4.9M cris

1.4M frv

856K h8300

4.6M ia64

8.0K Kconfig

1.4M m32r

5.7M m68k

1.1M m68knommu

1.2M microblaze

11M mips

1.7M mn10300

2.4M parisc

13M powerpc

2.4M s390

636K score

5.4M sh

4.7M sparc

1.9M tile

1.9M um

8.5M x86

1.4M xtensa

- arch/powerpc:

2.0M boot

548K configs

2.0M include

2.1M kernel

384K kvm

216K lib

204K math-emu

472K mm

156K oprofile

3.4M platforms

848K sysdev

392K xmon

- drivers/

accessibility	cpufreq	hwmon	mca	parisc	sbus	uio
acpi	cpuidle	i2c	md	parport	scsi	usb
amba	crypto	ide	media	pci	serial	uwb
ata	dca	idle	memstick	pcmcia	sfi	vhost
atm	dio	ieee802154	message	platform	sh	video
auxdisplay	dma	infiniband	mfd	pnv	sn	virtio
base	edac	input	misc	power	spi	vlynq
block	eisa	isdn	mmc	pps	ssb	w1
bluetooth	firewire	Kconfig	mtdev	ps3	staging	watchdog
cdrom	firmware	leds	net	rapidio	tc	xen
char	gpio	lguest	nubus	regulator	telephony	zorro
clocksource	gpu	macintosh	of	rtc	thermal	
connector	hid	Makefile	oprofile	s390	tty	

- **include/**

```
acpi          config  drm      keys     math-emu  mtd     pcmcia  rxrpc   sound  video
asm-generic  crypto  Kbuild  linux   media     net     rdma    scsi    trace  xen
```

- Looking for something:
  - Try `grep`
  - Have a look at the Linux Cross-Referencing project:
    - URL: <http://lxr.linux.no/>
    - Code: <http://lxr.sourceforge.net/>
  - Advanced kernel searching/understanding:
    - CScope: <http://cscope.sourceforge.net/>
    - KScope front-end: <http://kscope.sourceforge.net/>
  - ETAGS (emacs)

# 5. Process management

- Process descriptor (include/linux/sched.h: task\_struct):

Process state	=>	<i>state</i>
Identification	=>	<i>pid, tgid</i>
Relationship	=>	<i>*parent, children</i>
Scheduling	=>	<i>time_slice, sched_class,</i> <i>rt_priority, prio, static_prio</i>
Files	=>	<i>*files</i>
Memory	=>	<i>*mm</i>

- Main process list:
  - Doubly-linked list
  - List head: *init\_task*
- Currently running process (macro): *current*
- Task creation:
  - kernel/fork.c:*do\_fork()*
- Threads:
  - arch/ARCH/kernel/process.c:*sys\_clone()*
- *sys\_clone()* ends up calling *do\_fork()*

- Scheduling:
  - Process states: TASK\_RUNNING, TASK\_INTERRUPTIBLE, TASK\_UNINTERRUPTIBLE, TASK\_STOPPED, TASK\_TRACED, EXIT\_ZOMBIE, ...
  - Main scheduling function:  
kernel/sched.c: *schedule()*
  - Scheduling policies:
    - SCHED\_NORMAL
      - Main scheduling policy for Linux processes
    - SCHED\_FIFO:
      - Process has CPU until it gives it up or no other higher priority task comes along.
    - SCHED\_RR:
      - CPU is shared between “real-time” tasks
    - ...

- Address space:

- `include/linux/mm_types.h:mm_struct`
- Fields: *\*mmap, mm\_count, start\_code, end\_code, start\_data, end\_data, start\_brk, brk, start\_stack, arg\_start, arg\_end, env\_start, env\_end*

- Special tasks:

- `init` => first process on system
- `ksoftirqd/0` => soft-irq thread for avoiding process starvation
- `events/0` => kernel's work queue handler (was `keventd`)
- `khubd` => USB hub thread
- `kswapd0` => pageout daemon

# 6. Filesystems

- Virtual filesystem: fs/\*

attr.c	=>	file attributes
block_dev.c	=>	block device access
buffer.c	=>	buffer cache
char_dev.c	=>	char device access
dcache.c	=>	dentry (directory entry) cache
notify/	=>	directory change notifications
quot/	=>	disk quota
exec.c	=>	<i>exec()</i> and its variants
fcntl.c	=>	<i>fcntl()</i>
fifo.c	=>	FIFO handling
file.c	=>	manage process' fd array
file_table.c	=>	file table manipulation
inode.c	=>	inode handling
ioctl.c	=>	<i>ioctl()</i>
locks.c	=>	file locking

namei.c	=>	pathname lookup
namespace.c	=>	filesystem mounting
open.c	=>	<i>open()</i>
pipe.c	=>	pipe management
readdir.c	=>	directory reading
read_write.c	=>	<i>read()</i> and <i>write()</i> , and variants
select.c	=>	<i>select()</i> and <i>poll()</i>
stat.c	=>	<i>stat()</i>
super.c	=>	filesystem type management

- Root filesystem mounting: `init/do_mounts.c`  
*prepare\_namespace()*
- RAM disk handling (within `init/`):
  - `do_mounts_initrd.c`: *initrd\_load()*
  - `do_mounts_rd.c`: *rd\_load\_image()*, *identify\_ramdisk\_image()*
  - `do_mounts_initrd.c`: *handle\_initrd()*,

# 7. Memory management

- Arch-independent portion: mm/\*

bootmem.c	=>	boot memory allocation / handling
filemap.c	=>	handling for <i>mmap()</i> 'ed files
highmem.c	=>	RAM above 896MB / up to 64 GB
memory.c	=>	page and page table manipulation
mlock.c	=>	memory region locking
mmap.c	=>	<i>mmap()</i>
mprotect.c	=>	memory protection mechanisms
mremap.c	=>	<i>mremap()</i>
<i>nommu.c (2.5)</i>	=>	<i>functions for MMU-less processors</i>
oom_kill.c	=>	process killing when short on memory
page_alloc.c	=>	page allocation / freeing
page_io.c	=>	reading / writing swap pages
shmem.c	=>	shared memory management
slab.c	=>	memory allocation for kernel
swap.c	=>	swap default

swapfile.c	=>	swap space management
swap_state.c	=>	swap page caching
vmalloc.c	=>	memory region allocation
vmscan.c	=>	page out daemon

- **Architecture-dependent portion: arch/ARCH/mm/\***

fault.c	all =>	page fault handler
init.c	all =>	memory initialization
ioremap.c	x86=>	remapping of I/O range to kernel space
pageattr.c	x86=>	page attributes handling
pgtable.c	ppc=>	page table manipulation
ppc_mmu.c	ppc=>	MMU handling for PPC
tlb.c	ppc=>	TLB flushing

# 8. Communication facilities and interfacing

- Signals => kernel/signal.c
- Pipes => fs/pipe.c
- FIFOs => fs/fifo.c
- Sockets => net/socket.c
- System V IPC => ipc/ : msg.c, sem.c, shm.c
- System calls => arch/ARCH/kernel/entry.S
- Adding new system calls:
  1. Add entry to arch/ARCH/kernel/entry.S
  2. Add entry to arch/ARCH/include/unistd.h
  3. Add your function to the kernel's code

# 9. Loadable modules

- Allow dynamic loading and unloading of additional kernel functionality.
- Managed by: kernel/module.c
- In practice, modules are .ko files (.o prior to 2.6)
- A single module's source tree can have a very complex hierarchy.
- Every module must export functions using:  
*module\_init()*    =>    called on insmod  
*module\_exit()*    =>    called on rmmmod

- Module macros:

MODULE_AUTHOR	=> module's author
MODULE_LICENSE	=> module's license (taint)
MODULE_DESCRIPTION	=> module's description
EXPORT_SYMBOL	=> export symbol for use by other modules
MODULE_PARM_DESC	=> module parameter description

...

- Requesting modules from within the kernel:

*int request\_module(const char \* name, ...)*

# 10. Interrupt and exception management

- Relevant files:

- arch/x86/kernel/
  - i8259.c => initialization and handling of 8259
  - irq.c => arch-dependent irq handling
  - entry.S => main assembly entry point
  - traps.c => CPU exception handling
- kernel/irq/
  - handle.c => arch-independent irq handling (exc. ARM)

- Exception examples:

- debug, overflow, bounds, fp, fault, nmi, etc.

- Exceptions path:

1. arch/x86/kernel/entry.S: hard-coded assembly
2. arch/x86/kernel/traps.c: custom function or macro generated (DO\_ERROR).

- Hardware interrupt code:
  - arch/x86/kernel/entry.S: `irq_entries_start`
- Hardware interrupt path:
  1. Assembly in entry.S
  2. `do_IRQ()` in arch/x86/kernel/irq.c
  3. `__do_IRQ()` in kernel/irq/handle.c:
    1. Acks IRQ using callback from arch/x86/kernel/i8259.c:`mask_and_ack_8259A()`
    2. Calls `handle_IRQ_event()`
  4. Handler provided by device driver is invoked

- Deferring handling with enabled interrupts:
  - Softirq:
    - Statically allocated
    - Reentrant (must use locking mechanisms to protect data)
    - Softirqs of same type can run on many CPUs in the same time.
  - Tasklets:
    - Built on top of softirqs
    - Dynamically allocatable
    - The same tasklet type can't run on 2 CPUs in the same time.
  - Bottom-halves:
    - Built on top of tasklets
    - Statically allocated
    - There can only be one BH running at one time in the entire system.

# 11. Timing

- Time-keeping variables in the kernel: x86
  - jiffies* => incremented at every clock tick
  - wall\_jiffies* => last time xtime was updated
  - TSC => CPU-maintained counter (64-bit)
- Time handling:
  - arch/x86/kernel/time.c
- Finding out what time it is:
  - *do\_gettimeofday()*
  - *get\_cycles()*
  - *jiffies*

# 12. Locking primitives

- Never do cli / sti
- Always use existing locks to do the dirty-work
- Variants:
  - Spinlocks with IRQ disabling: good for int handlers

```
spin_lock_irqsave(&lock_var, cpu_flags);
```

```
....
```

```
spin_unlock_irqrestore(&lock_var, cpu_flags);
```

- Vanilla spinlocks: good for most code not in int

```
spin_lock(&lock_var);
```

```
....
```

```
spin_unlock(&lock_var);
```

- Read/write locks:

- In reader:

```
read_lock_irqsave(&lock_var, cpu_flags);
```

```
....
```

```
read_unlock_irqrestore(&lock_var, cpu_flags);
```

- In writer:

```
write_lock_irqsave(&lock_var, cpu_flags);
```

```
....
```

```
write_unlock_irqrestore(&lock_var, cpu_flags);
```

- For a complete list, have a look at `include/linux/spinlock.h`.

# 13. Kernel startup

Explanation for TQM860 PPC board

0. Kernel entry point:

`arch/ppc/boot/common/crt0.S: _start`

1. *\_start* calls on:

`arch/ppc/boot/simple/head.S: start`

2. *start* calls on:

`arch/ppc/boot/simple/relocate.S: relocate`

3. *relocate* calls on:

`arch/ppc/boot/simple/misc-embedded.c: load_kernel()`

4. *load\_kernel()* initializes the serial line and uncompresses kernel starting at address 0.

6. *relocate* jumps to address 0x00000000, where kernel start address is.
7. `arch/ppc/kernel/head_8xx.S: __start`
8. `__start` eventually calls `init/main.c:start_kernel()`
9. `load_kernel()` returns to *relocate*
10. `start_kernel()` does:
  1. Locks kernel
  2. `setup_arch()`
  3. `sched_init()`
  4. `parse_args()`
  5. `trap_init()`
  6. `init_IRQ()`

7. *time\_init()*

8. *console\_init()*

9. *mem\_init()*

10. *calibrate\_delay()*      =>      *loops\_per\_jiffy*

11. *rest\_init()*

**11. *rest\_init()* does:**

1. Start `init` thread
2. Unlocks the kernel
3. Becomes the idle task

## 12. The `init` task:

1. `lock_kernel()`

2. `do_basic_setup()`

=> call various `init()` fcts

3. `prepare_namespace()`

=> mount rootfs

4. `free_initmem()`

5. `unlock_kernel()`

6. `execve()` on the `init` program (`/sbin/init`)

# 14. Dealing with kernel failure

- Kernel is mature and stable, but can fail
- Kernel failure results in call to `kernel/panic.c:panic()`
- Reboot is as according to `panic= boot param` or default (180s)
- Default panic message goes to console
- Need to have your own panic handler
- Main list of callbacks on panic: `panic_notifier_list`.
- Register using `notifier_chain_register()`

```

#include <linux/kernel.h>
#include <linux/init.h>
#include <linux/notifier.h>

static int on_screen_panic_event(struct notifier_block *,
                                unsigned long,
                                void *);

static struct notifier_block on_screen_panic_block = {
    notifier_call:    on_screen_panic_event,
    next:            NULL,
    priority:        INT_MAX
};

int __init register_on_screen_panic(void)
{
    printk("Registering on-screen panic notifier \n");

    notifier_chain_register(&panic_notifier_list,
                           &on_screen_panic_block);

    return 0;
}

```

```
void write_raw_user_screen(void)
{
    ...
}

static int on_screen_panic_event(struct notifier_block *this,
                                unsigned long event,
                                void *ptr)
{
    write_raw_user_screen( );
    return NOTIFY_DONE;
}

__initcall(register_on_screen_panic);
```

# Device driver overview

- 1.Licensing reminder
- 2.Device driver model
- 3.Writing a char device driver
- 4.Writing a block device driver
- 5.Writing a network device driver
- 6.Writing an MTD map file
- 7.Writing a framebuffer driver
- 8.Time-keeping
- 9.Memory needs

10. Hardware access

11. Interrupt handling

12. Printing out messages to console

# 1. Licensing reminder

- Although the use of binary-only modules is widespread, Kernel modules are not immune to kernel GPL.
- Many kernel developers have come out rather strongly against binary-only modules.
- If you are linking a driver as built-in, then you are most certainly forbidden from distributing the resulting kernel under any license other than the GPL.
- If you're wary of the GPL, push critical driver-intelligence to user-space.

# 2. Device driver model

- Device files
  - Everything is a file in Unix, including devices
  - All devices are located in the `/dev` directory
  - Only networking devices do not have `/dev` nodes
  - Every device is identified by major / minor number
  - Can be allocated statically (`devices.txt`)
  - Can be allocated dynamically
  - To see devices present: `$ cat /proc/devices`
  - Alternatives: `devfs`, `sysfs` (used to be `driverfs`)

- Char devices:
  - Stream-oriented devices
  - Manipulated using: *struct file\_operations\**
- Block devices:
  - Disk-oriented devices
  - Manipulated using: *struct block\_device\_operations\**
- Networking devices
  - All networking devices
  - Manipulated using: *struct net\_device\**

- Subsystem drivers:

- USB:

- struct usb\_driver \**

- MTD:

- Chip driver: *struct mtd\_chip\_driver \**

- Device: *struct mtd\_info \**

- Framebuffer:

- struct fb\_info \**

# 3. Writing a char device driver

- Register char dev during module initialization
- Char dev registration: include/linux/fs.h

```
int register_chrdev(unsigned int,  
                   const char *,  
                   struct file_operations *);
```

- First param: Major number
- Second param: Device name (as displayed in /proc/devices)
- Third param: File-ops
  - Defined in include/linux/fs.h
  - Contains callbacks for all possible operations on a char device.

```

struct file_operations {
    struct module *owner;
    loff_t (*llseek) (struct file *, loff_t, int);
    ssize_t (*read) (struct file *, char __user *, size_t, loff_t *);
    ssize_t (*aio_read) (struct kiocb *, char __user *, size_t, loff_t);
    ssize_t (*write) (struct file *, const char __user *, size_t, loff_t *);
    ssize_t (*aio_write) (struct kiocb *, const char __user *, size_t, loff_t);
    int (*readdir) (struct file *, void *, filldir_t);
    unsigned int (*poll) (struct file *, struct poll_table_struct *);
    int (*ioctl) (struct inode *, struct file *, unsigned int, unsigned long);
    long (*unlocked_ioctl) (struct file *, unsigned int, unsigned long);
    long (*compat_ioctl) (struct file *, unsigned int, unsigned long);
    int (*mmap) (struct file *, struct vm_area_struct *);
    int (*open) (struct inode *, struct file *);
    int (*flush) (struct file *);
    int (*release) (struct inode *, struct file *);
    int (*fsync) (struct file *, struct dentry *, int datasync);
    int (*aio_fsync) (struct kiocb *, int datasync);
    int (*fasync) (int, struct file *, int);
    int (*lock) (struct file *, int, struct file_lock *);
    ssize_t (*readv) (struct file *, const struct iovec *, unsigned long, loff_t *);
    ssize_t (*writev) (struct file *, const struct iovec *, unsigned long, loff_t *);
    ssize_t (*sendfile) (struct file *, loff_t *, size_t, read_actor_t, void *);
    ssize_t (*sendpage) (struct file *, struct page *, int, size_t, loff_t *, int);
    unsigned long (*get_unmapped_area)(struct file *, unsigned long, unsigned ...
    int (*check_flags)(int);
    int (*dir_notify)(struct file *filp, unsigned long arg);
    int (*flock) (struct file *, int, struct file_lock *);
};

```

- Call *register\_chrdev()* and pass it a valid *file\_operations* structure.
- Return 0 from initialization function to tell insmod that everything is OK.
- That's it. Every time the device in /dev having the same major number as the one you registered is opened, you driver will be called.
- To remove char dev on rmmmod:

```
int unregister_chrdev(unsigned int,  
                      const char *);
```

# 4. Writing a block device driver

- Register block dev during module initialization
- Block dev registration: `include/linux/fs.h`

```
int register_blkdev(unsigned int,  
                    const char *);
```

- First param: Major number
  - Second param: Device name
  - Disk allocation: `include/linux/genhd.h`
- ```
struct gendisk *alloc_disk(int minors);
```
- Block queue registration: `include/linux/blkdev.h`
- ```
extern void blk_init_queue(request_fn_proc *,  
                           spinlock_t *);
```
- Queue of pending I/O operations for device

- First param: Queue handler function
- Second param: Lock for accessing queue
- Call *register\_blkdev()*.
- Call *alloc\_disk()* and pass it the number of disks.
- Call *blk\_init\_queue()* and pass it a valid callback.
- Return 0 from init function to tell insmod status

- Now, all block operations on your device (/dev entry with same major number as driver) will be queued to your driver.
- To remove block dev on rmmmod:

```
void blk_cleanup_queue(request_queue_t *);  
void put_disk(struct gendisk *disk);  
int unregister_blkdev(unsigned int, const char *);
```

# 5. Writing a network device driver

- Register net dev during module initialization
- Net dev registration: include/linux/netdevice.h

```
int register_netdevice(struct net_device *dev);
```
- Param: net device ops
  - Defined in include/linux/netdevice.h
  - Contains all callbacks related to network devices
  - This is a huge structure with A LOT of fields
- Call *register\_netdevice()* and pass it a valid *net\_device* structure.
- Return 0 as status to insmod

- Your device will need to be *opened* by the kernel in response to an *ifconfig* command.
- Your *open()* function must allocate a packet queue to deal with packets sent to your device.
- Calling your device will depend on packet routing at the upper layers of the stack.
- **To remove:** `unregister_netdev(struct net_device *dev);`

# 6. Writing an MTD map file

- Must find device in memory and then register it
- Finding a device in memory:  
include/linux/mtd/map.h

```
struct mtd_info *do_map_probe(char *name,  
                             struct map_info *map);
```

- First param: Type of probe (ex: “cfi\_probe”)
- Second param: map-info
  - Defined in include/linux/mtd/map.h
  - Information regarding size and buswidth
  - Functions for accessing chip

```

struct map_info {
char *name;
unsigned long size;
unsigned long phys;
#define NO_XIP (-1UL)

void __iomem *virt;
void *cached;

int bankwidth;
#ifdef CONFIG_MTD_COMPLEX_MAPPINGS
map_word (*read)(struct map_info *, unsigned long);
void (*copy_from)(struct map_info *, void *, unsigned long, ssize_t);

void (*write)(struct map_info *, const map_word, unsigned long);
void (*copy_to)(struct map_info *, unsigned long, const void *, ssize_t);
#endif
void (*inval_cache)(struct map_info *, unsigned long, ssize_t);

/* set_vpp() must handle being reentered -- enable, enable, disable
   must leave it enabled. */
void (*set_vpp)(struct map_info *, int);

unsigned long map_priv_1;
unsigned long map_priv_2;
void *fldrv_priv;
struct mtd_chip_driver *fldrv;
};

```

- Once located, use *add\_mtd\_partitions()* to provide partition information to MTD subsystem.

- *add\_mtd\_partition()* is in `include/linux/mtd/partitions.h`

```
int add_mtd_partitions(struct mtd_info *,
                      struct mtd_partition *,
                      int);
```

- First param: pointer returned by *do\_map\_probe()*
- Second param: partition information as we saw earlier.
- Third param: number of partitions

# 7. Writing a framebuffer driver

- Register framebuffer during module init
- Framebuffer registration: include/linux/fb.h

```
int register_framebuffer(struct fb_info *fb_info);
```

- Param: fb-info
  - Defined in include/linux/fb.h
  - Contains callbacks for all framebuffer operations

```

struct fb_info {
    int node;
    int flags;
    struct fb_var_screeninfo var; /* Current var */
    struct fb_fix_screeninfo fix; /* Current fix */
    struct fb_monspecs monspecs; /* Current Monitor specs */
    struct work_struct queue; /* Framebuffer event queue */
    struct fb_pixmap pixmap; /* Image hardware mapper */
    struct fb_pixmap sprite; /* Cursor hardware mapper */
    struct fb_cmap cmap; /* Current cmap */
    struct list_head modelist; /* mode list */
    struct fb_ops *fbops;
    struct device *device;
#ifdef CONFIG_FB_TILEBLITTING
    struct fb_tile_ops *tileops; /* Tile Blitting */
#endif
    char __iomem *screen_base; /* Virtual address */
    unsigned long screen_size; /* Amount of ioremapped VRAM or 0 */
    void *pseudo_palette; /* Fake palette of 16 colors */
#define FBINFO_STATE_RUNNING0
#define FBINFO_STATE_SUSPENDED 1
    u32 state; /* Hardware state i.e suspend */
    void *fbcon_par; /* fbcon use-only private area */
    /* From here on everything is device dependent */
    void *par;
};

```

- Call `register_framebuffer()` and pass it a valid `fb_info` structure.
- Return 0 from init code
- Access the `/dev/fbX` (where X is your framebuffer's registration order in relationship to other fb drivers) results in the functions provided in `fb_info` to be called.
- To remove fb dev on rmmmod:

```
int unregister_framebuffer(struct fb_info *fb_info);
```

# 8. Time-keeping

- Simple ways to get the time
  - *jiffies*: updated at every kernel tick
  - *do\_gettimeofday()*: good precision depending on arch
  - *get\_cycles()*: arch-independent call to get CPU cycle count.
- Being notified in due time:
  - Use timers: `include/linux/timer.h`
    - *jiffies* resolution
    - Use *struct timer\_list*: contains expiry and callback
    - Initialize timer: *init\_timer()*
    - Add timer to global timer list: *add\_timer()*
    - Remove timer before expiry: *del\_timer()*

# 9. Memory needs

- Main kernel memory functions:
  - *kmalloc(size, type)*: up to 128KB of memory
  - *vmalloc(size)*: get large contiguous virtual memory
- Main types of memory allocation:
  - GFP\_KERNEL           => normal alloc / may sleep
  - GFP\_ATOMIC           => int handlers / never sleeps
  - GFP\_USER              => user-space / low priority
  - ... See include/linux/slab.h for full list

# 10. Hardware access

- Main functions to be able to access hardware:
  - ISA:
    - Typical inb/outb
  - PCI:
    - Checking use of mem region: *check\_mem\_region()*
    - Requesting region: *request\_mem\_region()*
    - Releasing region: *release\_mem\_region()*
    - Map physical region to VM: *ioremap()*

# 11. Interrupt handling

- Setting up an interrupt handler:

```
extern int request_irq(unsigned int,  
                      irq_handler_t, unsigned long, const char *, void *);
```

- First param: IRQ number
- Second param: handler
- Third param: flags for OS int delivery
- Four param: device name
- Fifth param: provide device ID in case of shared interrupts.
- Disabling interrupt handler:  

```
void free_irq(unsigned int, void *);
```

# 12. Printing out messages to console

- Meet the kernel's printf: *printk()*
- Defined: `include/linux/kernel.h`

```
int printk(const char * fmt, ...)
```
- Implemented: `kernel/printk.c`
- Can lose data in cases of large output
- Widely-used throughout kernel sources
- Don't call while holding lock, has lock contention of its own.

# A Quick Java Introduction

1. Parts
2. Hello World
3. What's missing from C/C++?
4. What's different?

# 1. Parts

- JDK
  - Compiler
  - Libraries
- JRE
  - JVM
- Eclipse

# 2. Hello World

- The code:

```
class HelloWorld {  
    public static void main(String[] args) {  
        System.out.println("Hello World!");  
    }  
}
```

- Compiling:

```
$ javac HelloWorld.java
```

- Running:

```
$ java HelloWorld  
Hello World!  
$
```

# 3. What's missing from C/C++?

- Preprocessor:
  - #include
  - #define
  - #ifdef/#endif
- Definitions:
  - typedef
  - struct
  - union
  - enum

- Keywords:
  - goto
- Pointers:
  - malloc/free
- Strings as arrays of char:
  - Use `"foo".toCharArray()` to get a char array
  - Use `foo = new String(charArray)` to get a String

# 4. What's different?

- Garbage collection:

```
String myStr = new String("foo");  
myStr = null;  
myStr = new String("bar");
```

- String concatenation:

```
strC = strA + strB;
```

- Reflection:

```
// Direct call  
new MyClass().foo();
```

```
// Call through reflection reflection  
Class cls = Class.forName("MyClass");  
cls.getMethod("foo", null).invoke(cls.newInstance(), null);
```

- Interfaces:

```
interface Foo
{
    bar();
}

public class MyClass implements Foo {
    public bar() {
        ...
    }
}
```

- Can implement multiple interfaces (v. multiple inheritance)
- All methods declared as part of a class – no standalone “functions”

- Anonymous classes:

```
public class MyClass {  
    public static void main(String args[]) {  
        new Thread(new Runnable() {  
            @Override  
            public void run() {  
                System.out.println("Hello Anon");  
            }  
        }).start();  
    } // end main  
}
```

- Inheritance:

```
public class Foo extends Bar {  
    ...  
}
```

- Package (first line in source file):

```
package com.foo.mypackage;
```

- Importing (using a package):

```
import com.foo.mypackage;
```

- Threads:

```
public class MyThread extends Thread {
    public void run() {
        System.out.println("Hello Thread World!");
    }

    public static void main(String args[]) {
        (new MyThread()).start();
    }
}
```

- Synchronization:

```
public synchronized void foo() {
    ...
}
```

- Checking type:

```
public class Foo extends Bar {
    ...
}
...
foo myFoo = new Foo()
if (myFoo instanceof Bar) {
    ...
}
```

- Overrides:

```
public class Bar {
    public void aMethod() {
        ...
    }
}
```

```
public class Foo extends Bar {
    @Override
    public void aMethod() {
        ...
    }
}
```

- Arrays:

```
int[] myArray = new int[100];
```

- JavaDoc

- Junit

- JNI

- Packages:

```
java.applet
java.awt
java.awt.color
java.awt.datatransfer
java.awt.dnd
java.awt.event
java.awt.font
java.awt.geom
java.awt.im
java.awt.im.spi
java.awt.image
java.awt.image.renderable
java.awt.print
java.beans
java.beans.beancontext
java.io
java.lang
java.lang.ref
java.lang.reflect
java.math
java.net
java.nio
java.nio.channels
java.nio.channels.spi
java.nio.charset
java.nio.charset.spi
```

java.rmi  
java.rmi.activation  
java.rmi.dgc  
java.rmi.registry  
java.rmi.server  
java.security  
java.security.acl  
java.security.cert  
java.security.interfaces  
java.security.spec  
java.sql  
java.text  
java.util  
java.util.jar  
java.util.logging  
java.util.prefs  
java.util.regex  
java.util.zip  
javax.accessibility  
javax.crypto  
javax.crypto.interfaces  
javax.crypto.spec  
javax.imageio  
javax.imageio.event  
javax.imageio.metadata  
javax.imageio.plugins.jpeg  
javax.imageio.spi  
javax.imageio.stream  
javax.naming  
javax.naming.directory  
javax.naming.event  
javax.naming.ldap  
javax.naming.spi

javax.net  
javax.net.ssl  
javax.print  
javax.print.attribute  
javax.print.attribute.standard  
javax.print.event  
javax.rmi  
javax.rmi.CORBA  
javax.security.auth  
javax.security.auth.callback  
javax.security.auth.kerberos  
javax.security.auth.login  
javax.security.auth.spi  
javax.security.auth.x500  
javax.security.cert  
javax.sound.midi  
javax.sound.midi.spi  
javax.sound.sampled  
javax.sound.sampled.spi  
javax.sql  
javax.swing  
javax.swing.border  
javax.swing.colorchooser  
javax.swing.event  
javax.swing.filechooser  
javax.swing.plaf  
javax.swing.plaf.basic  
javax.swing.plaf.metal  
javax.swing.plaf.multi  
javax.swing.table  
javax.swing.text  
javax.swing.text.html  
javax.swing.text.html.parser  
javax.swing.text.rtf  
javax.swing.tree  
javax.swing.undo

```
javax.transaction
javax.transaction.xa
javax.xml.parsers
javax.xml.transform
javax.xml.transform.dom
javax.xml.transform.sax
javax.xml.transform.stream
org.ietf.jgss
org.omg.CORBA
org.omg.CORBA.DynAnyPackage
org.omg.CORBA.ORBPackage
org.omg.CORBA.TypeCodePackage
org.omg.CORBA.portable
org.omg.CORBA_2_3
org.omg.CORBA_2_3.portable
org.omg.CosNaming
org.omg.CosNaming.NamingContextExtPackage
org.omg.CosNaming.NamingContextPackage
org.omg.Dynamic
org.omg.DynamicAny
org.omg.DynamicAny.DynAnyFactoryPackage
org.omg.DynamicAny.DynAnyPackage
org.omg.IOP
org.omg.IOP.CodecFactoryPackage
org.omg.IOP.CodecPackage
org.omg.Messaging
```

org.omg.PortableInterceptor  
org.omg.PortableInterceptor.ORBInitInfoPackage  
org.omg.PortableServer  
org.omg.PortableServer.CurrentPackage  
org.omg.PortableServer.POAManagerPackage  
org.omg.PortableServer.POAPackage  
org.omg.PortableServer.ServantLocatorPackage  
org.omg.PortableServer.portable  
org.omg.SendingContext  
org.omg.stub.java.rmi  
org.w3c.dom  
org.xml.sax  
org.xml.sax.ext  
org.xml.sax.helpers

Thank you ...

[karim.yaghmour@opersys.com](mailto:karim.yaghmour@opersys.com)



## Acknowledgements:

- Some figures and snippets taken from Google's Android “Dev Guide” at [developer.android.com](http://developer.android.com) distributed under the Apache 2.0 license.